

# Diagnostic Trouble Code (DTC) Detecting Criteria

GENERAL DESCRIPTION

## 2. Diagnostic Trouble Code (DTC) Detecting Criteria

### A: DTC B1570 ANTENNA

#### 1. OUTLINE OF DIAGNOSIS

DTC	Item	OUTLINE OF DIAGNOSIS
B1570	Antenna	Faulty antenna
B1571	Reference Code Incompatibility	Reference code incompatibility between body integrated unit and ECM
B1572	IMM Circuit Failure (Except Antenna Circuit)	Communication failure between body integrated unit and ECM
B1574	Key Communication Failure	The body integrated unit to confirm the key (transponder) ID code has malfunction, of the transponder is faulty.
B1575	Incorrect Immobilizer Key	Incorrect immobilizer key (Use of unregistered key in body integrated unit)
B1576	EGI Control Module EEPROM	ECM malfunctioning
B1577	IMM Control Module EEPROM	Body integrated unit malfunctioning
B1578	Meter Failure	Reference code incompatibility between combination meter and body integrated unit

#### 2. ENABLE CONDITIONS

When starting the engine.

#### 3. GENERAL DRIVING CYCLE

Perform the diagnosis only after starting the engine.

#### 4. DIAGNOSTIC METHOD

Judge as NG when the conditions for the outline of the diagnosis of the top are established.

# Diagnostic Trouble Code (DTC) Detecting Criteria

## GENERAL DESCRIPTION

---

### **B: DTC B1571 REFERENCE CODE INCOMPATIBILITY**

#### **1. OUTLINE OF DIAGNOSIS**

**NOTE:**

For the detection standard, refer to DTC B1570. <Ref. to GD(w/o STI)-11, DTC B1570 ANTENNA, Diagnostic Trouble Code (DTC) Detecting Criteria.>

### **C: DTC B1572 IMM CIRCUIT FAILURE (EXCEPT ANTENNA CIRCUIT)**

#### **1. OUTLINE OF DIAGNOSIS**

**NOTE:**

For the detection standard, refer to DTC B1570. <Ref. to GD(w/o STI)-11, DTC B1570 ANTENNA, Diagnostic Trouble Code (DTC) Detecting Criteria.>

### **D: DTC B1574 KEY COMMUNICATION FAILURE**

#### **1. OUTLINE OF DIAGNOSIS**

**NOTE:**

For the detection standard, refer to DTC B1570. <Ref. to GD(w/o STI)-11, DTC B1570 ANTENNA, Diagnostic Trouble Code (DTC) Detecting Criteria.>

### **E: DTC B1575 INCORRECT IMMOBILIZER KEY**

#### **1. OUTLINE OF DIAGNOSIS**

**NOTE:**

For the detection standard, refer to DTC B1570. <Ref. to GD(w/o STI)-11, DTC B1570 ANTENNA, Diagnostic Trouble Code (DTC) Detecting Criteria.>

### **F: DTC B1576 EGI CONTROL MODULE EEPROM**

#### **1. OUTLINE OF DIAGNOSIS**

**NOTE:**

For the detection standard, refer to DTC B1570. <Ref. to GD(w/o STI)-11, DTC B1570 ANTENNA, Diagnostic Trouble Code (DTC) Detecting Criteria.>

### **G: DTC B1577 IMM CONTROL MODULE EEPROM**

#### **1. OUTLINE OF DIAGNOSIS**

**NOTE:**

For the detection standard, refer to DTC B1570. <Ref. to GD(w/o STI)-11, DTC B1570 ANTENNA, Diagnostic Trouble Code (DTC) Detecting Criteria.>

### **H: DTC B1578 METER FAILURE**

#### **1. OUTLINE OF DIAGNOSIS**

**NOTE:**

For the detection standard, refer to DTC B1570. <Ref. to GD(w/o STI)-11, DTC B1570 ANTENNA, Diagnostic Trouble Code (DTC) Detecting Criteria.>

# Diagnostic Trouble Code (DTC) Detecting Criteria

GENERAL DESCRIPTION

## I: DTC P000A A CAMSHAFT POSITION SLOW RESPONSE (BANK 1)

### 1. OUTLINE OF DIAGNOSIS

Detect the AVCS system malfunction.

Judge NG when the amount of AVCS actual timing advance does not approach to the amount of AVCS target timing advance.

### 2. ENABLE CONDITIONS

Secondary Parameters	Enable Conditions
Battery voltage	≥ 10.9 V
AVCS control	In operation
Target timing advance change amount (per 80 ms)	< 4°CA

### 3. GENERAL DRIVING CYCLE

Perform the diagnosis continuously while AVCS is operating.

### 4. DIAGNOSTIC METHOD

When the differences of target timing advance amount and actual timing advance amount is calculated during AVCS control, and the difference per predetermined time is the specified value or larger.

Judge as NG when the following conditions are established within the predetermined time.

#### Judgment Value

Malfunction Criteria	Threshold Value
$\Sigma(\text{Target position} - \text{Actual position})$	> 4000°CA or < -4000°CA

**Time Needed for Diagnosis:** 25 seconds

**Malfunction Indicator Light Illumination:** Illuminates when malfunction occurs in 2 continuous driving cycles.

## J: DTC P000B B CAMSHAFT POSITION SLOW RESPONSE (BANK 1)

### 1. OUTLINE OF DIAGNOSIS

Detect the exhaust AVCS system malfunction.

Judge NG when the amount of exhaust AVCS actual timing advance does not approach the amount of exhaust AVCS target timing advance.

### 2. ENABLE CONDITIONS

Secondary Parameters	Enable Conditions
Battery voltage	≥ 10.9 V
Exhaust AVCS control	In operation
Target timing advance change amount (per 80 ms)	< 4°CA

### 3. GENERAL DRIVING CYCLE

Perform the diagnosis continuously while exhaust AVCS is operating.

# Diagnostic Trouble Code (DTC) Detecting Criteria

## GENERAL DESCRIPTION

---

### 4. DIAGNOSTIC METHOD

When the differences of target timing advance amount and actual timing advance amount is calculated during exhaust AVCS control, and the difference per predetermined time is the specified value or larger.

Judge as NG when the following conditions are established within the predetermined time.

#### Judgment Value

Malfunction Criteria	Threshold Value
$\Sigma(\text{Target position} - \text{Actual position})$	> 4500°CA or < -4500°CA

**Time Needed for Diagnosis:** 25 seconds

**Malfunction Indicator Light Illumination:** Illuminates when malfunction occurs in 2 continuous driving cycles.

### **K: DTC P000C A CAMSHAFT POSITION SLOW RESPONSE (BANK 2)**

#### 1. OUTLINE OF DIAGNOSIS

NOTE:

For the detection standard, refer to DTC P000A. <Ref. to GD(w/o STI)-13, DTC P000A A CAMSHAFT POSITION SLOW RESPONSE (BANK 1), Diagnostic Trouble Code (DTC) Detecting Criteria.>

### **L: DTC P000D B CAMSHAFT POSITION SLOW RESPONSE (BANK 2)**

#### 1. OUTLINE OF DIAGNOSIS

NOTE:

For the detection standard, refer to DTC P000B. <Ref. to GD(w/o STI)-13, DTC P000B B CAMSHAFT POSITION SLOW RESPONSE (BANK 1), Diagnostic Trouble Code (DTC) Detecting Criteria.>

# Diagnostic Trouble Code (DTC) Detecting Criteria

GENERAL DESCRIPTION

## M: DTC P0010 "A" CAMSHAFT POSITION ACTUATOR CIRCUIT/OPEN (BANK 1)

### 1. OUTLINE OF DIAGNOSIS

Detect the open/short circuit of oil control solenoid valve.

Judge as NG when the current is small even though the duty signal is large, or when the current is large even though the duty signal is small.

### 2. ENABLE CONDITIONS

#### Diagnosis 1

Secondary Parameters	Enable Conditions
Battery voltage	$\geq 10.9$ V
Oil control solenoid control duty	$\geq 99.6\%$

#### Diagnosis 2

Secondary Parameters	Enable Conditions
Battery voltage	$\geq 10.9$ V
Oil control solenoid control duty	$< 8\%$

### 3. GENERAL DRIVING CYCLE

Always perform the diagnosis continuously.

### 4. DIAGNOSTIC METHOD

If the duration of time while the following conditions are met is longer than the time indicated, judge as NG.

#### Diagnosis 1

##### Judgment Value

Malfunction Criteria	Threshold Value
Oil control solenoid control present current	$< 0.306$ A

#### Diagnosis 2

##### Judgment Value

Malfunction Criteria	Threshold Value
Present current of the oil control solenoid	$\geq 0.306$ A

**Time Needed for Diagnosis:** 2000 ms

**Malfunction Indicator Light Illumination:** Illuminates as soon as a malfunction occurs.

# Diagnostic Trouble Code (DTC) Detecting Criteria

## GENERAL DESCRIPTION

### N: DTC P0011 INTAKE CAMSHAFT POSITION - TIMING OVER-ADVANCED OR SYSTEM PERFORMANCE (BANK 1)

#### 1. OUTLINE OF DIAGNOSIS

Detect the AVCS system malfunction.

Judge as NG when the conditions during which the differences of AVCS target timing advance amount and AVCS actual timing advance amount is large continues.

#### 2. ENABLE CONDITIONS

- Normal

Secondary Parameters	Enable Conditions
Battery voltage AVCS control	≥ 10.9 V In operation

- Intermediate lock

Secondary Parameters	Enable Conditions
Battery voltage Engine speed Elapsed time after starting the engine	≥ 10.9 V ≥ 500 rpm > 500 ms and ≤ Value from Map

#### Map

Engine coolant temperature °C (°F)	-40 (-40)	-30 (-22)	-20 (-4)	-10 (14)	0 (32)	10 (50)	20 (68)	30 (86)
Elapsed time after starting the engine s	10	10	10	8	5	4	3	3

Engine coolant temperature °C (°F)	40 (104)	50 (122)	60 (140)	70 (158)	80 (176)	90 (194)	100 (212)	110 (230)
Elapsed time after starting the engine s	3	3	3	4	4	4	4	4

#### 3. GENERAL DRIVING CYCLE

- Normal

Perform the diagnosis continuously while AVCS is operating.

- Intermediate lock

Perform the diagnosis when the AVCS is carrying out the intermediate lock control at the engine start.

# Diagnostic Trouble Code (DTC) Detecting Criteria

GENERAL DESCRIPTION

## 4. DIAGNOSTIC METHOD

When the conditions during which the differences of AVCS target timing advance amount and AVCS actual timing advance amount is large continues for certain amount of time.

Judge as NG when the following conditions are established within the predetermined time.

### Judgment Value

Malfunction Criteria	Threshold Value
<ul style="list-style-type: none"><li>• Normal  Vtd  Vtd = VVT target position – VVT actual position</li></ul>	> 10°CA
<ul style="list-style-type: none"><li>• Intermediate lock  Vtd </li></ul>	> 10°CA

### Time Needed for Diagnosis:

- Normal: 10 seconds
- Intermediate lock: 2 seconds

**Malfunction Indicator Light Illumination:** Illuminates when malfunction occurs in 2 continuous driving cycles.

# Diagnostic Trouble Code (DTC) Detecting Criteria

## GENERAL DESCRIPTION

### O: DTC P0013 B CAMSHAFT POSITION ACTUATOR CIRCUIT/OPEN (BANK 1)

#### 1. OUTLINE OF DIAGNOSIS

Detect the open/short circuit of oil control solenoid valve.

Judge as NG when the current is small even though the duty signal is large, or when the current is large even though the duty signal is small.

#### 2. ENABLE CONDITIONS

##### Diagnosis 1

Secondary Parameters	Enable Conditions
Battery voltage	$\geq 10.9$ V
Oil control solenoid control duty	$\geq 99.6\%$

##### Diagnosis 2

Secondary Parameters	Enable Conditions
Battery voltage	$\geq 10.9$ V
Oil control solenoid control duty	$< 8\%$

#### 3. GENERAL DRIVING CYCLE

Always perform the diagnosis continuously.

#### 4. DIAGNOSTIC METHOD

If the duration of time while the following conditions are met is longer than the time indicated, judge as NG.

##### Diagnosis 1

##### Judgment Value

Malfunction Criteria	Threshold Value
Oil control solenoid control present current	$< 0.306$ A

##### Diagnosis 2

##### Judgment Value

Malfunction Criteria	Threshold Value
Present current of the oil control solenoid	$\geq 0.306$ A

**Time Needed for Diagnosis:** 2000 ms

**Malfunction Indicator Light Illumination:** Illuminates as soon as a malfunction occurs.



# Diagnostic Trouble Code (DTC) Detecting Criteria

GENERAL DESCRIPTION

## P: DTC P0014 EXHAUST AVCS SYSTEM 1 (RANGE/PERFORMANCE)

### 1. OUTLINE OF DIAGNOSIS

Detect the exhaust AVCS system malfunction.

Judge as NG when the conditions during which the differences of exhaust AVCS target timing advance amount and exhaust AVCS actual timing advance amount is large continues.

### 2. ENABLE CONDITIONS

Secondary Parameters	Enable Conditions
Battery voltage	$\geq 10.9$ V
Exhaust AVCS control	In operation

### 3. GENERAL DRIVING CYCLE

Perform the diagnosis continuously while exhaust AVCS is operating.

### 4. DIAGNOSTIC METHOD

When the conditions during which the differences of exhaust AVCS target timing advance amount and exhaust AVCS actual timing advance amount is large continues for certain amount of time.

Judge as NG when the following conditions are established within the predetermined time.

#### Judgment Value

Malfunction Criteria	Threshold Value
$ Vtd $ $Vtd = VVT \text{ target position} - VVT \text{ actual position}$	$> 10^{\circ}CA$

**Time Needed for Diagnosis:** 10 seconds

**Malfunction Indicator Light Illumination:** Illuminates when malfunction occurs in 2 continuous driving cycles.

# Diagnostic Trouble Code (DTC) Detecting Criteria

## GENERAL DESCRIPTION

### Q: DTC P0016 CRANKSHAFT POSITION - CAMSHAFT POSITION CORRELATION (BANK1)

#### 1. OUTLINE OF DIAGNOSIS

Detect the AVCS system malfunction.

Judge as NG when standard timing advance amount is far from learning angle.

#### 2. ENABLE CONDITIONS

Secondary Parameters	Enable Conditions
Battery voltage	$\geq 10.9$ V
Elapsed time after external load (power steering, neutral position switch) change	$\geq 3$ s
AVCS position learning	In operation
AVCS position learning experience flag (Only used for diagnosis 1)	Set

#### 3. GENERAL DRIVING CYCLE

Perform the diagnosis continuously after starting engine and while AVCS is not operating.

#### 4. DIAGNOSTIC METHOD

Judge as NG when the absolute value of the difference between cam signal input position and learning value is out of specification.

If the duration of time while the following conditions are met is longer than the time indicated, judge as NG.

##### Diagnosis 1

##### Judgment Value

Malfunction Criteria	Threshold Value
Crankshaft position when camshaft position sensor signal is input – Learning value	$> 10^{\circ}\text{CA}$

##### Diagnosis 2

##### Judgment Value

Malfunction Criteria	Threshold Value
Camshaft position sensor signal input position	$< 53^{\circ}\text{CA}$ or $> 112^{\circ}\text{CA}$

**Time Needed for Diagnosis:** 1 second

**Malfunction Indicator Light Illumination:** Illuminates when malfunction occurs in 2 continuous driving cycles.

##### NOTE:

Initial standard learning value is the value of crank angle initially input at the production plant. And then it will be updated every time normal judgment has been completed. Learning value will not be updated if NG judgment occurs because timing belt or chain derails suddenly in process or because wrong assembly occurs during servicing.

# Diagnostic Trouble Code (DTC) Detecting Criteria

GENERAL DESCRIPTION

## R: DTC P0017 CRANK AND CAM TIMING B SYSTEM FAILURE (BANK 1)

### 1. OUTLINE OF DIAGNOSIS

Detect the exhaust AVCS system malfunction.

Judge as NG when standard timing advance amount is far from learning angle.

### 2. ENABLE CONDITIONS

Secondary Parameters	Enable Conditions
Battery voltage	≥ 10.9 V
Elapsed time after external load (power steering, neutral position switch) change	≥ 3 s
Exhaust AVCS position learning	In operation
Exhaust AVCS position learning experience flag (Only used for diagnosis 1)	Set

### 3. GENERAL DRIVING CYCLE

Perform the diagnosis continuously while the exhaust AVCS is not operating after warming up.

### 4. DIAGNOSTIC METHOD

Judge as NG when the absolute value of the difference between cam signal input position and learning value is out of specification.

If the duration of time while the following conditions are met is longer than the time indicated, judge as NG.

#### Diagnosis 1

##### Judgment Value

Malfunction Criteria	Threshold Value
Crankshaft position when camshaft position sensor signal is input – Learning value	> 10°CA

#### Diagnosis 2

##### Judgment Value

Malfunction Criteria	Threshold Value
Camshaft position sensor signal input position	< 78°CA or > 137°CA

**Time Needed for Diagnosis:** 5 seconds

**Malfunction Indicator Light Illumination:** Illuminates when malfunction occurs in 2 continuous driving cycles.

#### NOTE:

Initial standard learning value is the value of crank angle initially input at the production plant. And then it will be updated every time normal judgment has been completed. Learning value will not be updated if NG judgment occurs because timing belt or chain derails suddenly in process or because wrong assembly occurs during servicing.

## Diagnostic Trouble Code (DTC) Detecting Criteria

### GENERAL DESCRIPTION

---

#### **S: DTC P0018 CRANKSHAFT POSITION - CAMSHAFT POSITION CORRELATION (BANK2)**

##### **1. OUTLINE OF DIAGNOSIS**

###### NOTE:

For the detection standard, refer to DTC P0016. <Ref. to GD(w/o STI)-20, DTC P0016 CRANKSHAFT POSITION - CAMSHAFT POSITION CORRELATION (BANK1), Diagnostic Trouble Code (DTC) Detecting Criteria.>

#### **T: DTC P0019 CRANK AND CAM TIMING B SYSTEM FAILURE (BANK 2)**

##### **1. OUTLINE OF DIAGNOSIS**

###### NOTE:

For the detection standard, refer to DTC P0017. <Ref. to GD(w/o STI)-21, DTC P0017 CRANK AND CAM TIMING B SYSTEM FAILURE (BANK 1), Diagnostic Trouble Code (DTC) Detecting Criteria.>

#### **U: DTC P0020 "A" CAMSHAFT POSITION ACTUATOR CIRCUIT/OPEN (BANK 2)**

##### **1. OUTLINE OF DIAGNOSIS**

###### NOTE:

For the detection standard, refer to DTC P0010. <Ref. to GD(w/o STI)-15, DTC P0010 "A" CAMSHAFT POSITION ACTUATOR CIRCUIT/OPEN (BANK 1), Diagnostic Trouble Code (DTC) Detecting Criteria.>

#### **V: DTC P0021 INTAKE CAMSHAFT POSITION - TIMING OVER-ADVANCED OR SYSTEM PERFORMANCE (BANK 2)**

##### **1. OUTLINE OF DIAGNOSIS**

###### NOTE:

For the detection standard, refer to DTC P0011. <Ref. to GD(w/o STI)-16, DTC P0011 INTAKE CAMSHAFT POSITION - TIMING OVER-ADVANCED OR SYSTEM PERFORMANCE (BANK 1), Diagnostic Trouble Code (DTC) Detecting Criteria.>

#### **W: DTC P0023 B CAMSHAFT POSITION ACTUATOR CIRCUIT/OPEN (BANK 2)**

##### **1. OUTLINE OF DIAGNOSIS**

###### NOTE:

For the detection standard, refer to DTC P0013. <Ref. to GD(w/o STI)-18, DTC P0013 B CAMSHAFT POSITION ACTUATOR CIRCUIT/OPEN (BANK 1), Diagnostic Trouble Code (DTC) Detecting Criteria.>

#### **X: DTC P0024 EXHAUST AVCS SYSTEM 2 (RANGE/PERFORMANCE)**

##### **1. OUTLINE OF DIAGNOSIS**

###### NOTE:

For the detection standard, refer to DTC P0014. <Ref. to GD(w/o STI)-19, DTC P0014 EXHAUST AVCS SYSTEM 1 (RANGE/PERFORMANCE), Diagnostic Trouble Code (DTC) Detecting Criteria.>

#### **Y: DTC P0030 HO2S HEATER CONTROL CIRCUIT (BANK 1 SENSOR 1)**

##### **1. OUTLINE OF DIAGNOSIS**

Detect functional errors of the front oxygen (A/F) sensor heater.

Judge as NG when it is determined that the front oxygen (A/F) sensor impedance is large when looking at engine status such as deceleration fuel cut.

# Diagnostic Trouble Code (DTC) Detecting Criteria

GENERAL DESCRIPTION

## 2. COMPONENT DESCRIPTION

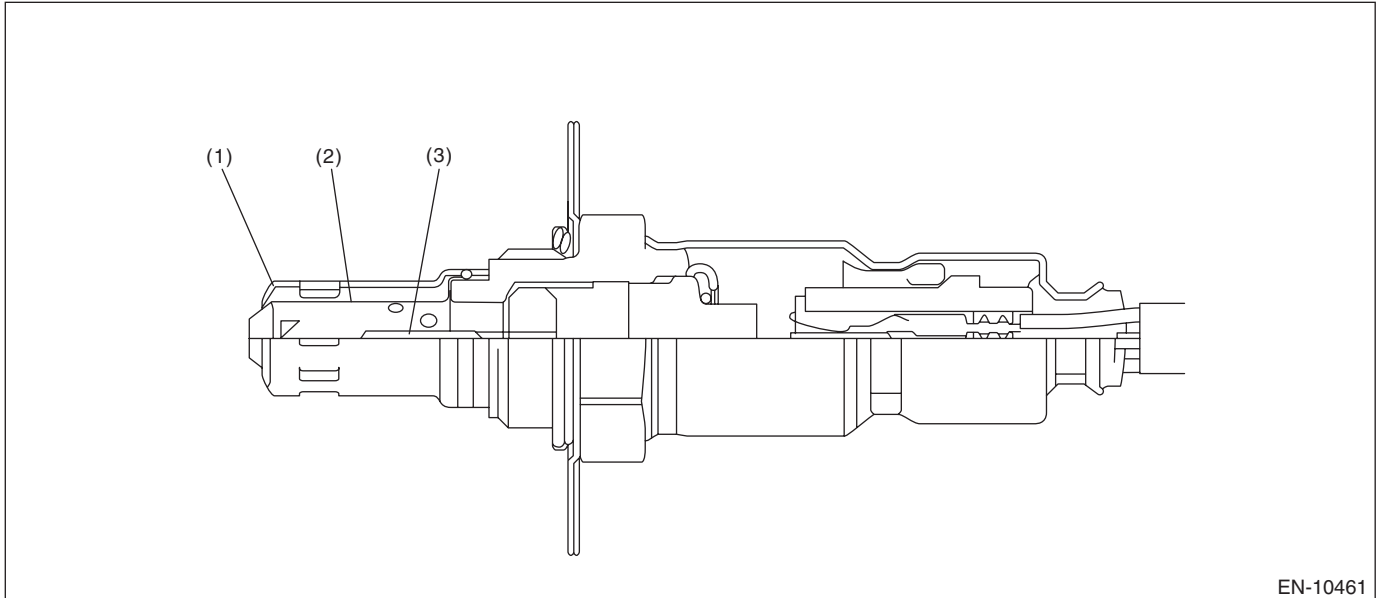

EN-10461

(1) Element cover (outer)

(2) Element cover (inner)

(3) Sensor element

## 3. ENABLE CONDITIONS

Secondary Parameters	Enable Conditions
Battery voltage	$\geq 10.9 \text{ V}$
A/F sensor heater duty	$> 21\%$

## 4. GENERAL DRIVING CYCLE

Perform the diagnosis continuously after starting the engine.

## 5. DIAGNOSTIC METHOD

If the duration of time while the following conditions are met is longer than the time indicated, judge as NG.

### Judgment Value

Malfunction Criteria	Threshold Value
Front oxygen (A/F) sensor impedance	$> 100 \Omega$

**Time Needed for Diagnosis:** 25 seconds

**Malfunction Indicator Light Illumination:** Illuminates when malfunction occurs in 2 continuous driving cycles.

# Diagnostic Trouble Code (DTC) Detecting Criteria

## GENERAL DESCRIPTION

---

### Z: DTC P0031 HO2S HEATER CONTROL CIRCUIT LOW (BANK 1 SENSOR 1)

#### 1. OUTLINE OF DIAGNOSIS

Detect front oxygen (A/F) sensor heater open or short circuit.

The front oxygen (A/F) sensor heater performs duty control, and the output terminal voltage at ON is 0 V, and the output terminal voltage at OFF is the battery voltage.

Judge as NG when the terminal voltage remains Low.

#### 2. ENABLE CONDITIONS

Secondary Parameters	Enable Conditions
Battery voltage	$\geq 10.9$ V
Front oxygen (A/F) sensor heater control duty	$\leq 80\%$

#### 3. GENERAL DRIVING CYCLE

Always perform the diagnosis continuously.

#### 4. DIAGNOSTIC METHOD

If the duration of time while the following conditions are met is longer than the time indicated, judge as NG.

##### Judgment Value

Malfunction Criteria	Threshold Value
Output voltage	$\leq 2.2$ V

**Time Needed for Diagnosis:** 1000 ms

**Malfunction Indicator Light Illumination:** Illuminates as soon as a malfunction occurs.

# Diagnostic Trouble Code (DTC) Detecting Criteria

GENERAL DESCRIPTION

## AA:DTC P0032 HO2S HEATER CONTROL CIRCUIT HIGH (BANK 1 SENSOR 1)

### 1. OUTLINE OF DIAGNOSIS

Detect front oxygen (A/F) sensor heater open or short circuit.

The front oxygen (A/F) sensor heater performs duty control, and the output terminal voltage at ON is 0 V, and the output terminal voltage at OFF is the battery voltage.

Judge as NG when overcurrent is detected.

### 2. ENABLE CONDITIONS

Secondary Parameters	Enable Conditions
Battery voltage	$\geq 10.9$ V
Front oxygen (A/F) sensor heater control duty	$\geq 20\%$

### 3. GENERAL DRIVING CYCLE

Always perform the diagnosis continuously.

### 4. DIAGNOSTIC METHOD

If the duration of time while the following conditions are met is longer than the time indicated, judge as NG.

#### Judgment Value

Malfunction Criteria	Threshold Value
Output current	$\geq 17$ A

**Time Needed for Diagnosis:** 2250 ms

**Malfunction Indicator Light Illumination:** Illuminates as soon as a malfunction occurs.

# Diagnostic Trouble Code (DTC) Detecting Criteria

## GENERAL DESCRIPTION

### AB:DTC P0037 HO2S HEATER CONTROL CIRCUIT LOW (BANK 1 SENSOR 2)

#### 1. OUTLINE OF DIAGNOSIS

Detect the rear oxygen sensor heater open or short circuit.

The rear oxygen sensor heater performs duty control, and the output terminal voltage at ON is 0 V, and the output terminal voltage at OFF is the battery voltage.

Judge as NG when the terminal voltage remains Low.

#### 2. ENABLE CONDITIONS

Secondary Parameters	Enable Conditions
Battery voltage	$\geq 10.9 \text{ V}$
Rear oxygen sensor heater control duty	$\leq 96\%$

#### 3. GENERAL DRIVING CYCLE

Always perform the diagnosis continuously.

#### 4. DIAGNOSTIC METHOD

If the duration of time while the following conditions are met is longer than the time indicated, judge as NG.

##### Judgment Value

Malfunction Criteria	Threshold Value
Output voltage	$\leq 2.2 \text{ V}$

**Time Needed for Diagnosis:** 2500 ms

**Malfunction Indicator Light Illumination:** Illuminates when malfunction occurs in 2 continuous driving cycles.



# Diagnostic Trouble Code (DTC) Detecting Criteria

GENERAL DESCRIPTION

## AC:DTC P0038 HO2S HEATER CONTROL CIRCUIT HIGH (BANK 1 SENSOR 2)

### 1. OUTLINE OF DIAGNOSIS

Detect the rear oxygen sensor heater open or short circuit.

The rear oxygen sensor heater performs duty control, and the output terminal voltage at ON is 0 V, and the output terminal voltage at OFF is the battery voltage.

Judge as NG when overcurrent is detected.

### 2. ENABLE CONDITIONS

Secondary Parameters	Enable Conditions
Battery voltage	$\geq 10.9$ V
Rear oxygen sensor heater control duty	$\geq 4\%$

### 3. GENERAL DRIVING CYCLE

Always perform the diagnosis continuously.

### 4. DIAGNOSTIC METHOD

If the duration of time while the following conditions are met is longer than the time indicated, judge as NG.

#### Judgment Value

Malfunction Criteria	Threshold Value
Output current	$\geq 17$ A

**Time Needed for Diagnosis:** 2500 ms

**Malfunction Indicator Light Illumination:** Illuminates when malfunction occurs in 2 continuous driving cycles.

# Diagnostic Trouble Code (DTC) Detecting Criteria

## GENERAL DESCRIPTION

### AD:DTC P0068 MAP/MAF - THROTTLE POSITION CORRELATION

#### 1. OUTLINE OF DIAGNOSIS

Detect problems in the manifold absolute pressure sensor output properties.

Judge as NG when the intake air pressure AD value is Low whereas it seemed to be High from the viewpoint of engine condition, or when it is High whereas it seemed to be Low from the engine condition.

#### 2. COMPONENT DESCRIPTION

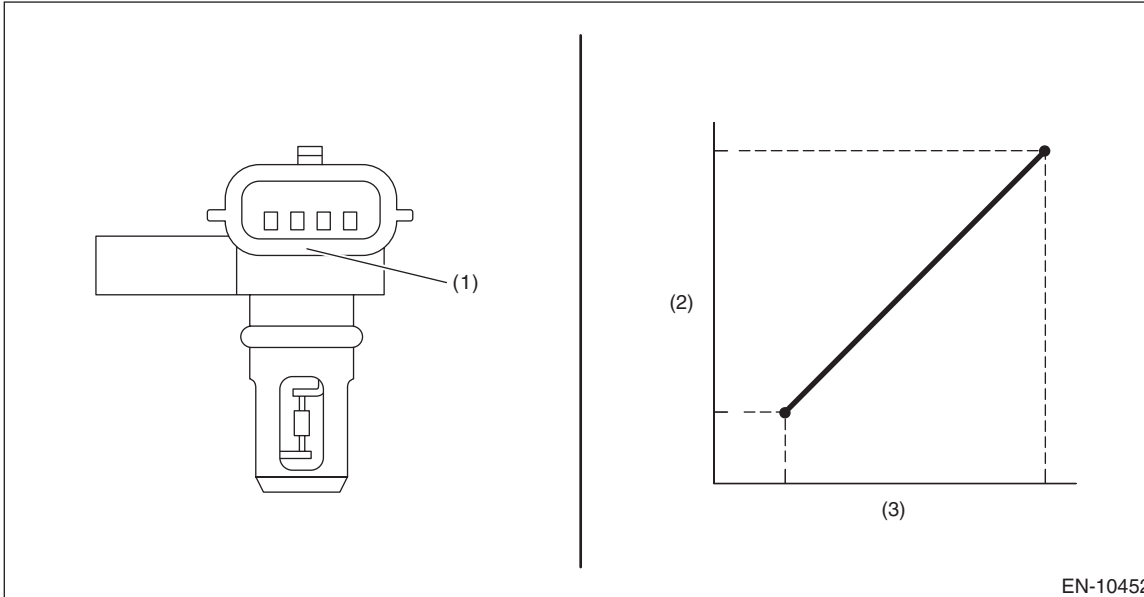

(1) Manifold absolute pressure sensor

(2) Voltage (V)

(3) Absolute pressure (kPa)

EN-10452

#### 3. ENABLE CONDITIONS

##### Low

Secondary Parameters	Enable Conditions
Engine coolant temperature	$\geq 55^{\circ}\text{C}$ ( $131^{\circ}\text{F}$ )
Engine speed	$< 3600$ rpm
Charging efficiency	$\geq 35\%$
Throttle position	$\geq 8.9\%$

##### High

Secondary Parameters	Enable Conditions
Engine coolant temperature	$\geq 55^{\circ}\text{C}$ ( $131^{\circ}\text{F}$ )
Engine speed	$\geq 475$ rpm and $< 950$ rpm
Charging efficiency	$\leq 30\%$
Throttle position	$\leq 4.8\%$

#### 4. GENERAL DRIVING CYCLE

Perform the diagnosis continuously after idling.

# Diagnostic Trouble Code (DTC) Detecting Criteria

GENERAL DESCRIPTION

## 5. DIAGNOSTIC METHOD

Judge as NG when Low side or High side becomes NG.

If the duration of time while the following conditions are met is longer than the time indicated, judge as NG.

### Judgment Value

Malfunction Criteria	Threshold Value
<b>Low</b> Intake manifold pressure (absolute pressure)	< 30 kPa (225 mmHg, 8.9 inHg)
<b>High</b> Intake manifold pressure (absolute pressure)	≥ 100 kPa (750.1 mmHg, 29.5 inHg)

### Time Needed for Diagnosis:

Low side: 5000 ms

High side: 5000 ms

**Malfunction Indicator Light Illumination:** Illuminates when malfunction occurs in 2 continuous driving cycles.

# Diagnostic Trouble Code (DTC) Detecting Criteria

## GENERAL DESCRIPTION

### AE:DTC P0071 AMBIENT TEMPERATURE SENSOR CIRCUIT "A" RANGE/PERFORMANCE

#### 1. OUTLINE OF DIAGNOSIS

Detect the malfunction of ambient temperature sensor characteristics.

After the engine starts after the specified period of soaking time has elapsed, judge by correlation between ambient temperature sensor value, intake air temperature sensor value and engine coolant temperature sensor value. Judge as NG when the differences are both above the specified value by comparing between ambient air temperature and intake air temperature, ambient air temperature and engine coolant temperature.

#### 2. COMPONENT DESCRIPTION

Ambient temperature sensor is connected to combination meter. ECM receives the data of ambient temperature sensor via CAN communication with combination meter.

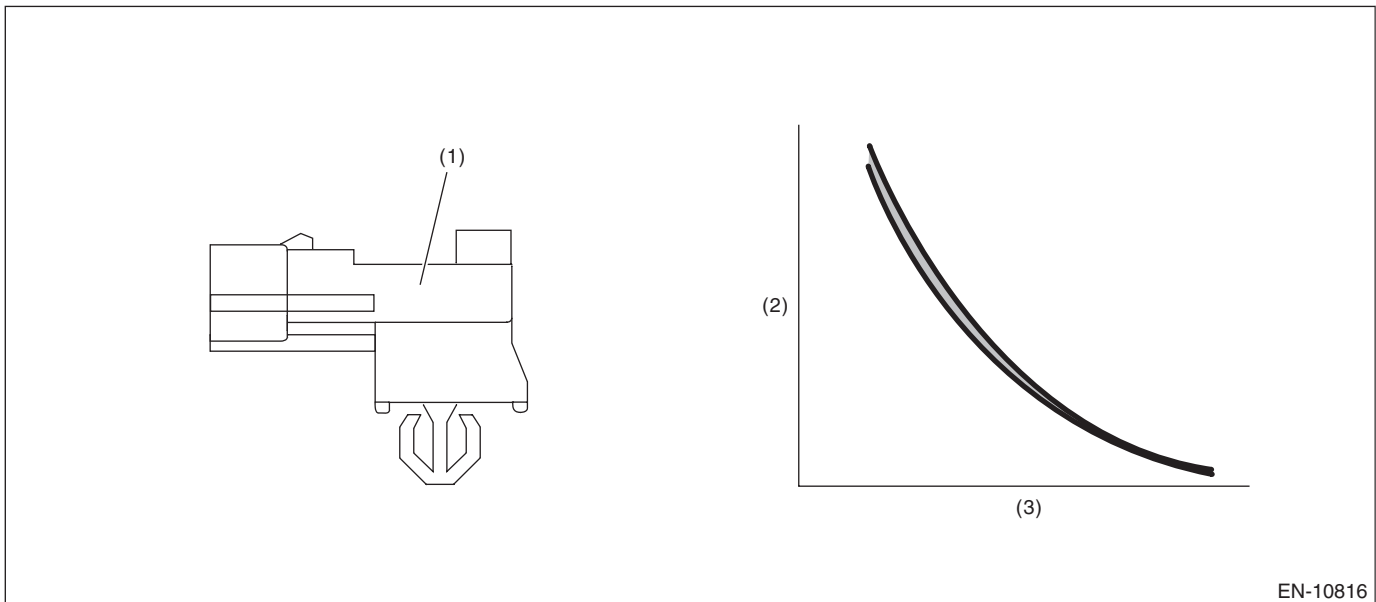

(1) Ambient temperature sensor

(2) Resistance value (k $\Omega$ )

(3) Ambient air temperature ( $^{\circ}\text{C}$  ( $^{\circ}\text{F}$ ))

#### 3. ENABLE CONDITIONS

Secondary Parameters	Enable Conditions
Soaking time	$\geq 21600$ s
Block heater judgment	Completed
Block heater operation	Not in operation

#### 4. GENERAL DRIVING CYCLE

Perform the diagnosis only once after the engine starts after a certain period of soaking time.

# Diagnostic Trouble Code (DTC) Detecting Criteria

GENERAL DESCRIPTION

## 5. DIAGNOSTIC METHOD

Judge as NG when the following conditions are established.

### Judgment Value

Malfunction Criteria	Threshold Value
Ambient air temperature 30 sec. after engine start – Intake air temperature 30 sec. after engine start	> Value from Map
Ambient air temperature at engine start – Engine coolant temperature at engine start	> 25°C (45°F)

### Map

Ambient air temperature °C (°F)	-30 (-22)	30 (86)	45 (113)	60 (140)
Ambient air temperature 30 sec. after engine start – Intake air temperature 30 sec. after engine start  °C (°F)	20 (36)	20 (36)	32 (57.6)	32 (57.6)

**Time Needed for Diagnosis:** Less than 1 second

**Malfunction Indicator Light Illumination:** Illuminates when malfunction occurs in 2 continuous driving cycles.

# Diagnostic Trouble Code (DTC) Detecting Criteria

## GENERAL DESCRIPTION

### AF:DTC P0072 AMBIENT TEMPERATURE SENSOR CIRCUIT "A" LOW

#### 1. OUTLINE OF DIAGNOSIS

Detect the open or short circuit of ambient temperature sensor.  
Judge as NG if out of specification.

#### 2. COMPONENT DESCRIPTION

Ambient temperature sensor is connected to combination meter. ECM receives the data of ambient temperature sensor via CAN communication with combination meter.

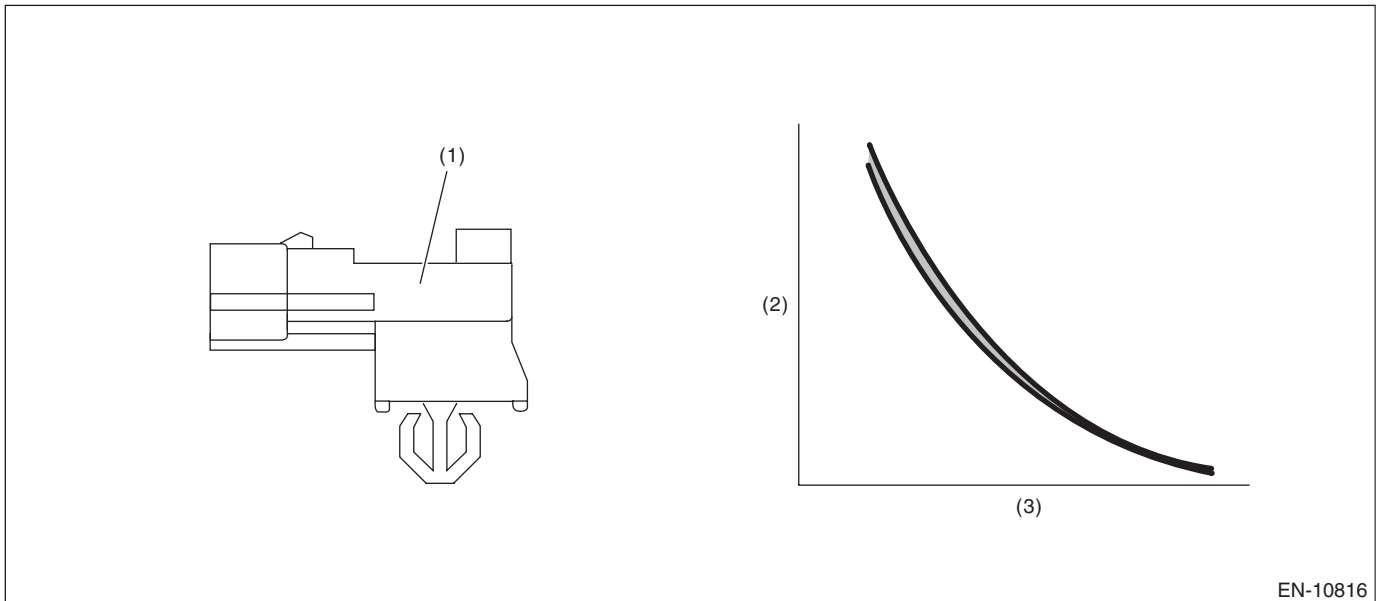

(1) Ambient temperature sensor

(2) Resistance value (kΩ)

(3) Ambient air temperature (°C (°F))

#### 3. ENABLE CONDITIONS

Secondary Parameters	Enable Conditions
Battery voltage	$\geq 10.9$ V

#### 4. GENERAL DRIVING CYCLE

Always perform the diagnosis continuously after the enable conditions have been established.

#### 5. DIAGNOSTIC METHOD

If the duration of time while the following conditions are met is longer than the time indicated, judge as NG.

##### Judgment Value

Malfunction Criteria	Threshold Value
Output voltage	$< 0.42$ V

**Time Needed for Diagnosis:** 2.56 seconds

**Malfunction Indicator Light Illumination:** Illuminates as soon as a malfunction occurs.

## AG:DTC P0073 AMBIENT TEMPERATURE SENSOR CIRCUIT "A" HIGH

### 1. OUTLINE OF DIAGNOSIS

Detect the open or short circuit of ambient temperature sensor.  
Judge as NG if out of specification.

### 2. COMPONENT DESCRIPTION

Ambient temperature sensor is connected to combination meter. ECM receives the data of ambient temperature sensor via CAN communication with combination meter.

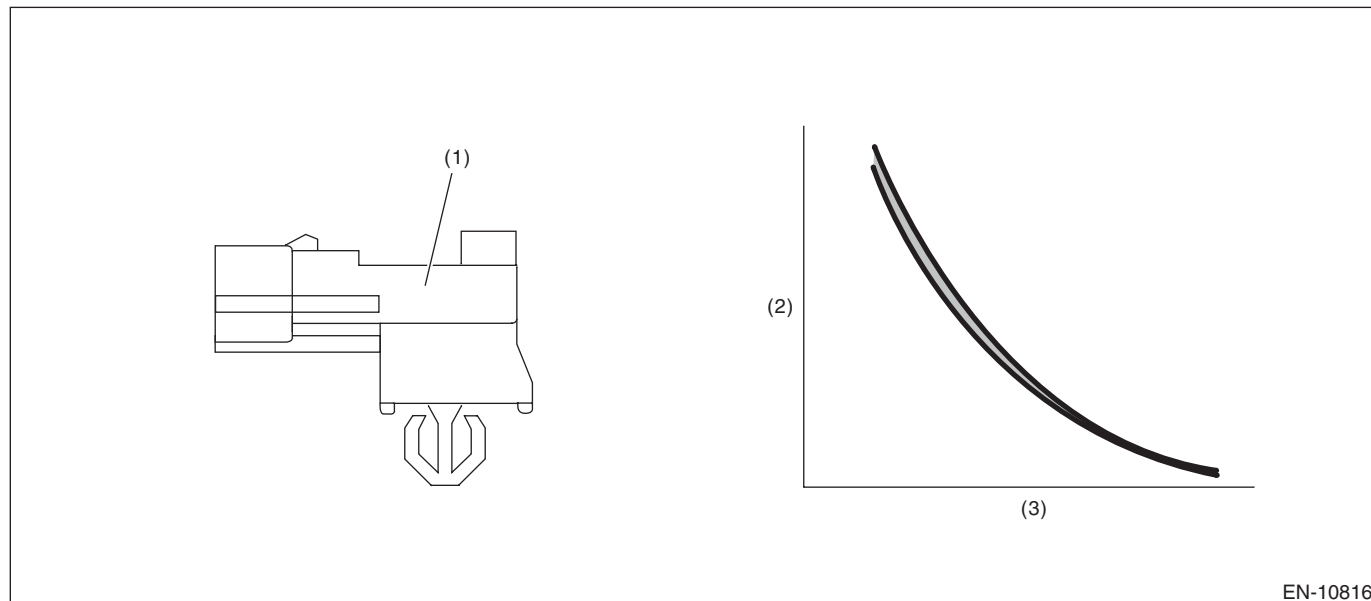

EN-10816

- (1) Ambient temperature sensor      (2) Resistance value (kΩ)      (3) Ambient air temperature (°C (°F))

### 3. ENABLE CONDITIONS

Secondary Parameters	Enable Conditions
Battery voltage	≥ 10.9 V

### 4. GENERAL DRIVING CYCLE

Always perform the diagnosis continuously after the enable conditions have been established.

### 5. DIAGNOSTIC METHOD

If the duration of time while the following conditions are met is longer than the time indicated, judge as NG.

#### Judgment Value

Malfunction Criteria	Threshold Value
Output voltage	> 4.88 V

**Time Needed for Diagnosis:** 2.56 seconds

**Malfunction Indicator Light Illumination:** Illuminates as soon as a malfunction occurs.

## AH:DTC P0087 FUEL RAIL/SYSTEM PRESSURE - TOO LOW

### 1. OUTLINE OF DIAGNOSIS

NOTE:

For the detection standard, refer to DTC P0088. <Ref. to GD(w/o STI)-34, DTC P0088 FUEL RAIL/SYSTEM PRESSURE - TOO HIGH, Diagnostic Trouble Code (DTC) Detecting Criteria.>

# Diagnostic Trouble Code (DTC) Detecting Criteria

## GENERAL DESCRIPTION

---

### AI: DTC P0088 FUEL RAIL/SYSTEM PRESSURE - TOO HIGH

#### 1. OUTLINE OF DIAGNOSIS

Detect the malfunction of high pressure fuel system function.

Judge as NG when actual pressure is not close to target pressure.

#### 2. ENABLE CONDITIONS

Secondary Parameters	Enable Conditions
Continuous time after fuel cut	> 3 s
Target pressure change every 10 ms	≤ 500 kPa (3750.3 mmHg, 147.7 inHg)

#### 3. GENERAL DRIVING CYCLE

Always perform the diagnosis continuously.

#### 4. DIAGNOSTIC METHOD

If the duration of time while the following conditions are met is longer than the time indicated, judge as NG.

##### Judgment Value

Malfunction Criteria	Threshold Value	DTC
Target fuel pressure – Actual fuel pressure	> 3300 kPa (24752.1 mmHg, 974.5 inHg)	P0087
Actual fuel pressure – Target fuel pressure	> 6000 kPa (45003.8 mmHg, 1771.8 inHg)	P0088

**Time Needed for Diagnosis:** 10 seconds

**Malfunction Indicator Light Illumination:** Illuminates as soon as a malfunction occurs.



# Diagnostic Trouble Code (DTC) Detecting Criteria

GENERAL DESCRIPTION

## AJ:DTC P0096 INTAKE AIR TEMPERATURE SENSOR #2 RANGE/PERFORMANCE PROBLEM

### 1. OUTLINE OF DIAGNOSIS

Detect the malfunction of the intake air temperature sensor (integrated with manifold absolute pressure sensor) output properties. Using the following two diagnoses, judge as NG when either is NG.

- **Diagnosis 1 (correlation diagnosis):** After the engine starts after the specified period of soaking time has elapsed, diagnose by correlation between intake air temperature sensor value, engine coolant temperature sensor value and ambient temperature sensor value. Judge as NG when the differences are both above the specified value by comparing between intake air temperature and engine coolant temperature, intake air temperature and ambient air temperature.
- **Diagnosis 2 (stuck diagnosis):** Judge as NG when intake air temperature does not change under the driving condition where it should change, considering engine condition.

### 2. COMPONENT DESCRIPTION

Intake air temperature sensor (integrated with manifold absolute pressure sensor)

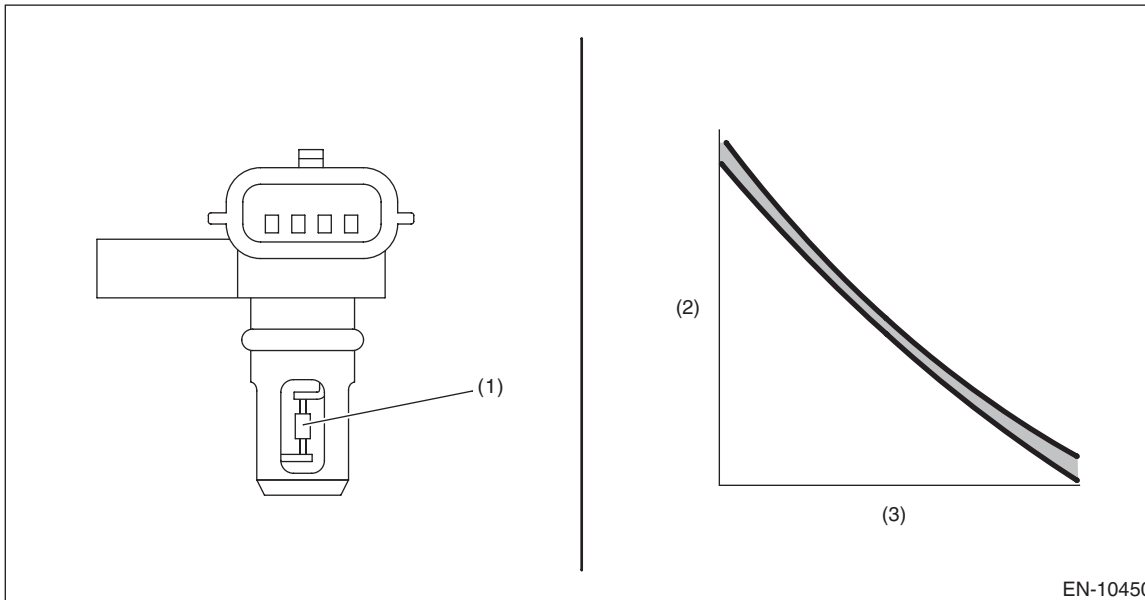

(1) Intake air temperature sensor

(2) Resistance value ( $\Omega$ )

(3) Intake air temperature  $^{\circ}\text{C}$  ( $^{\circ}\text{F}$ )

### 3. ENABLE CONDITIONS

#### Diagnosis 1

Secondary Parameters	Enable Conditions
Soaking time	$\geq 21600$ s
Block heater judgment	Completed
Block heater operation	Not in operation

#### Diagnosis 2

Secondary Parameters	Enable Conditions
Battery voltage	$\geq 10.9$ V
Engine coolant temperature	$\geq 60^{\circ}\text{C}$ ( $140^{\circ}\text{F}$ )
Intake air amount sum value	$\geq 6,500$ g
Number of experiences under conditions below	$\geq 3$ times
• Continuous time when vehicle speed is less than 4 km/h (2.5 MPH)	$\geq 24$ s
• Continuous time when the vehicle speed is 40 km/h (24.9 MPH) or more, and intake air amount is 10 g/s (0.4 oz/s) or more	$\geq 10$ s

# Diagnostic Trouble Code (DTC) Detecting Criteria

## GENERAL DESCRIPTION

### 4. GENERAL DRIVING CYCLE

- **Diagnosis 1:** Perform the diagnosis only once after the engine starts after a certain period of soaking time.
- **Diagnosis 2:** Perform the diagnosis when the vehicle speed condition is met after warming up from a cold condition.

### 5. DIAGNOSTIC METHOD

Judge as NG when Diagnosis 1 or Diagnosis 2 becomes NG.

#### Diagnosis 1

If the duration of time while the following conditions are met is longer than the time indicated, judge as NG.

#### Judgment Value

Malfunction Criteria	Threshold Value
Intake air temperature (manifold absolute pressure sensor) 30 sec. after engine start – Intake air temperature (air flow sensor) 30 sec. after engine start	> Value of Map 1
Intake air temperature (manifold absolute pressure sensor) 30 sec. after engine start – Ambient air temperature 30 sec. after engine start	> Value of Map 2

#### Map 1

Ambient air temperature °C (°F)	-30 (-22)	30 (86)	45 (113)	60 (140)
Intake air temperature (manifold absolute pressure sensor) 30 sec. after engine start – Intake air temperature (air flow sensor) 30 sec. after engine start  °C (°F)	11 (19.8)	11 (19.8)	11 (19.8)	11 (19.8)

#### Map 2

Ambient air temperature °C (°F)	-30 (-22)	30 (86)	45 (113)	60 (140)
Intake air temperature (manifold absolute pressure sensor) 30 sec. after engine start – Ambient air temperature 30 sec. after engine start  °C (°F)	20 (36)	20 (36)	32 (57.6)	32 (57.6)

**Time Needed for Diagnosis:** Less than 1 second

#### Diagnosis 2

Judge as NG when the following conditions are established.

#### Judgment Value

Malfunction Criteria	Threshold Value
Output voltage difference between Max. and Min.	< 0.02 V (Equivalent to approximately 0.5°C (0.9°F) near 25°C (77°F))

**Time Needed for Diagnosis:** Less than 1 second

**Malfunction Indicator Light Illumination:** Illuminates when malfunction occurs in 2 continuous driving cycles.

# Diagnostic Trouble Code (DTC) Detecting Criteria

GENERAL DESCRIPTION

## AK:DTC P0097 INTAKE AIR TEMPERATURE SENSOR #2 CIRCUIT (LOW)

### 1. OUTLINE OF DIAGNOSIS

Detect open or short circuit of the intake air temperature sensor (integrated with manifold absolute pressure sensor).

Judge as NG if out of specification.

### 2. COMPONENT DESCRIPTION

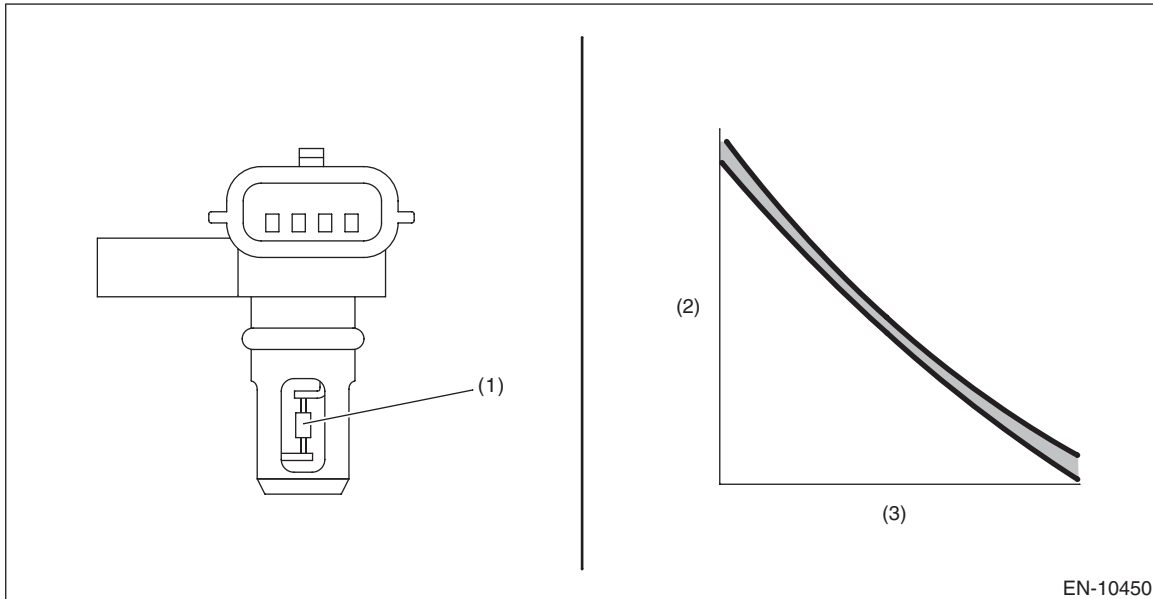

(1) Intake air temperature sensor

(2) Resistance value (kΩ)

(3) Intake air temperature (°C (°F))

### 3. ENABLE CONDITIONS

Secondary Parameters	Enable Conditions
None	

### 4. GENERAL DRIVING CYCLE

Always perform the diagnosis continuously.

### 5. DIAGNOSTIC METHOD

If the duration of time while the following conditions are met is longer than the time indicated, judge as NG.

#### Judgment Value

Malfunction Criteria	Threshold Value
Output voltage	< 0.22 V

**Time Needed for Diagnosis:** 520 ms

**Malfunction Indicator Light Illumination:** Illuminates as soon as a malfunction occurs.

# Diagnostic Trouble Code (DTC) Detecting Criteria

## GENERAL DESCRIPTION

### AL:DTC P0098 INTAKE AIR TEMPERATURE SENSOR #2 CIRCUIT (HIGH)

#### 1. OUTLINE OF DIAGNOSIS

Detect open or short circuit of the intake air temperature sensor (integrated with manifold absolute pressure sensor).

Judge as NG if out of specification.

#### 2. COMPONENT DESCRIPTION

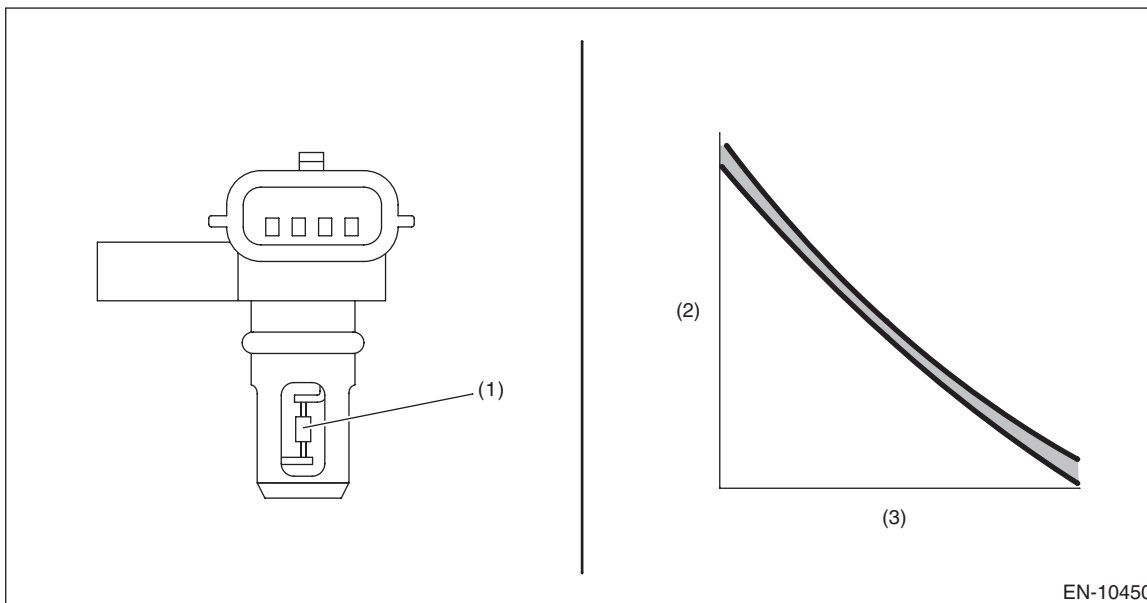

(1) Intake air temperature sensor

(2) Resistance value (kΩ)

(3) Intake air temperature (°C (°F))

#### 3. ENABLE CONDITIONS

Secondary Parameters	Enable Conditions
None	

#### 4. GENERAL DRIVING CYCLE

Always perform the diagnosis continuously.

#### 5. DIAGNOSTIC METHOD

If the duration of time while the following conditions are met is longer than the time indicated, judge as NG.

##### Judgment Value

Malfunction Criteria	Threshold Value
Output voltage	> 4.72 V

**Time Needed for Diagnosis:** 520 ms

**Malfunction Indicator Light Illumination:** Illuminates as soon as a malfunction occurs.

# Diagnostic Trouble Code (DTC) Detecting Criteria

GENERAL DESCRIPTION

## AM:DTC P0101 MASS OR VOLUME AIR FLOW CIRCUIT RANGE/PERFORMANCE

### 1. OUTLINE OF DIAGNOSIS

Detect the malfunction of air flow sensor output properties.

Judge as a low side NG when the air flow voltage indicates a small value regardless of running in a state where the air flow voltage increases. Judge as a high side NG when the air flow voltage indicates a large value regardless of running in a state where the air flow voltage decreases. Judge air flow sensor property NG when the Low side or High side becomes NG.

### 2. COMPONENT DESCRIPTION

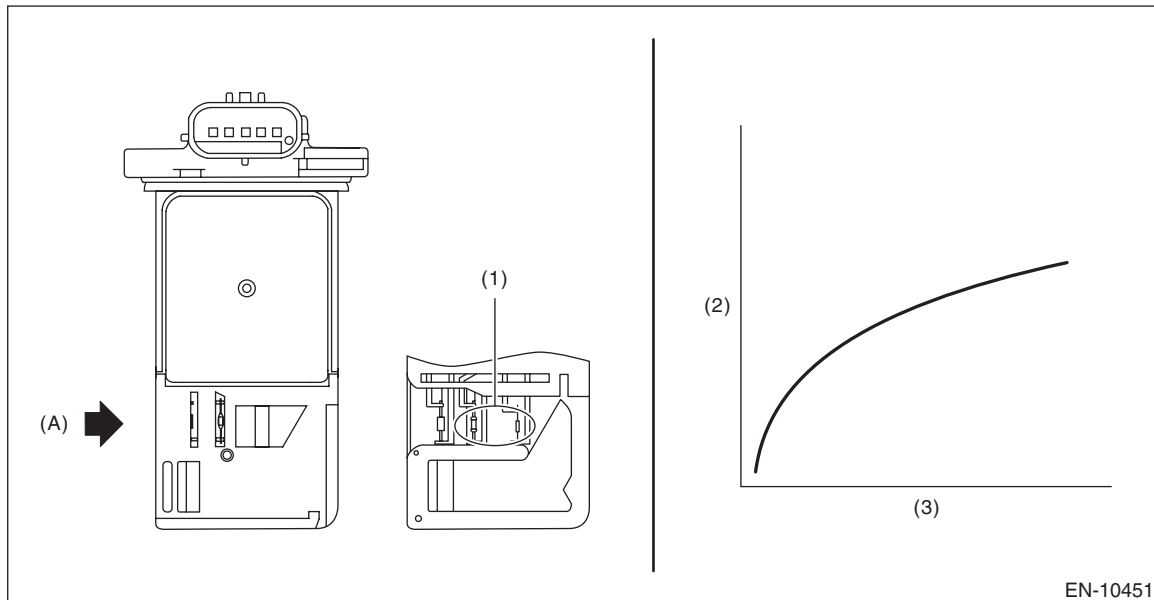

(A) Air

(1) Air flow sensor

(2) Voltage (V)

(3) Intake air amount (g (oz)/s)

### 3. ENABLE CONDITIONS

#### Low

Secondary Parameters	Enable Conditions
Engine speed	$\geq 1500$ rpm
Throttle position	$\geq 12.6\%$
Engine coolant temperature	$\geq 60^{\circ}\text{C}$ ( $140^{\circ}\text{F}$ )
Intake manifold pressure	$\geq 90$ kPa (675.1 mmHg, 26.6 inHg)

#### High

Secondary Parameters	Enable Conditions
Engine speed	$\geq 475$ rpm and $< 915$ rpm
Throttle position	$< 6.3\%$
Engine coolant temperature	$\geq 60^{\circ}\text{C}$ ( $140^{\circ}\text{F}$ )
Intake manifold pressure	$< 64$ kPa (480 mmHg, 18.9 inHg)

# Diagnostic Trouble Code (DTC) Detecting Criteria

## GENERAL DESCRIPTION

---

### 4. GENERAL DRIVING CYCLE

Perform the diagnosis continuously after idling.

### 5. DIAGNOSTIC METHOD

Judge as NG when Low side or High side becomes NG.

If the duration of time while the following conditions are met is longer than the time indicated, judge as NG.

#### Judgment Value

Malfunction Criteria	Threshold Value
<b>Low</b> Output voltage	< 1.05 V
<b>High</b> Output voltage	≥ 1.75 V

#### Time Needed for Diagnosis:

Low: 5 s

High: 10 s

**Malfunction Indicator Light Illumination:** Illuminates when malfunction occurs in 2 continuous driving cycles.

# Diagnostic Trouble Code (DTC) Detecting Criteria

GENERAL DESCRIPTION

## AN:DTC P0102 MASS OR VOLUME AIR FLOW CIRCUIT LOW INPUT

### 1. OUTLINE OF DIAGNOSIS

Detect open or short circuits of the air flow sensor.  
Judge as NG if out of specification.

### 2. COMPONENT DESCRIPTION

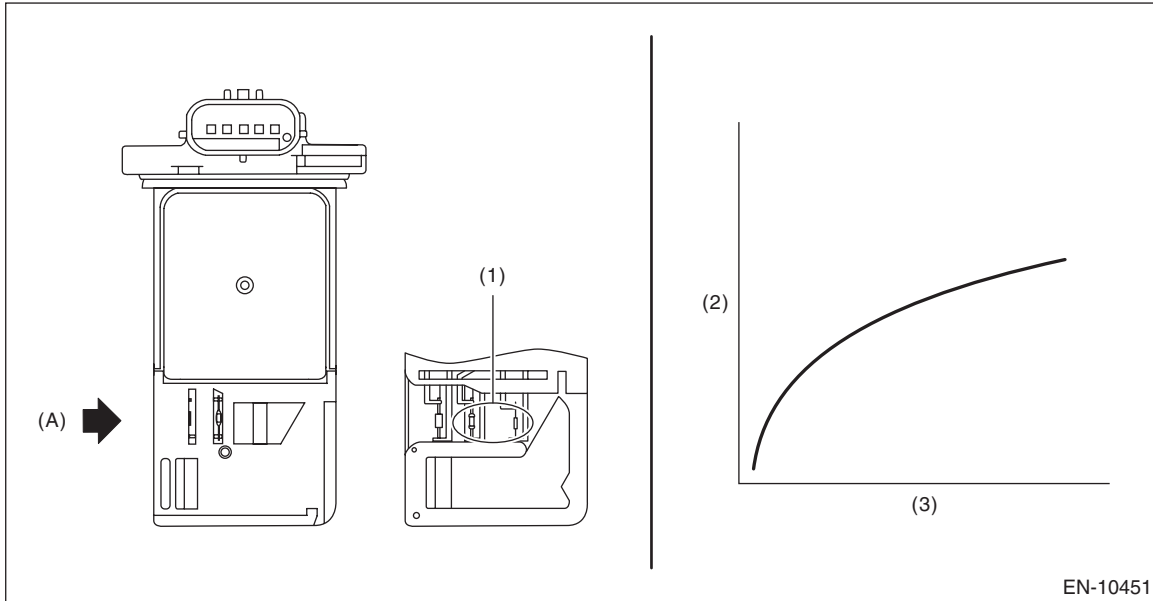

(A) Air

(1) Air flow sensor

(2) Voltage (V)

(3) Intake air amount (g (oz)/s)

### 3. ENABLE CONDITIONS

Secondary Parameters	Enable Conditions
Elapsed time after ignition switch is turned to ON	< 1040 ms

### 4. GENERAL DRIVING CYCLE

Always perform the diagnosis continuously.

### 5. DIAGNOSTIC METHOD

If the duration of time while the following conditions are met is longer than the time indicated, judge as NG.

#### Judgment Value

Malfunction Criteria	Threshold Value
Output voltage	< 0.12 V

**Time Needed for Diagnosis:** 520 ms

**Malfunction Indicator Light Illumination:** Illuminates as soon as a malfunction occurs.

# Diagnostic Trouble Code (DTC) Detecting Criteria

## GENERAL DESCRIPTION

### AO:DTC P0103 MASS OR VOLUME AIR FLOW CIRCUIT HIGH INPUT

#### 1. OUTLINE OF DIAGNOSIS

Detect open or short circuits of the air flow sensor.  
Judge as NG if out of specification.

#### 2. COMPONENT DESCRIPTION

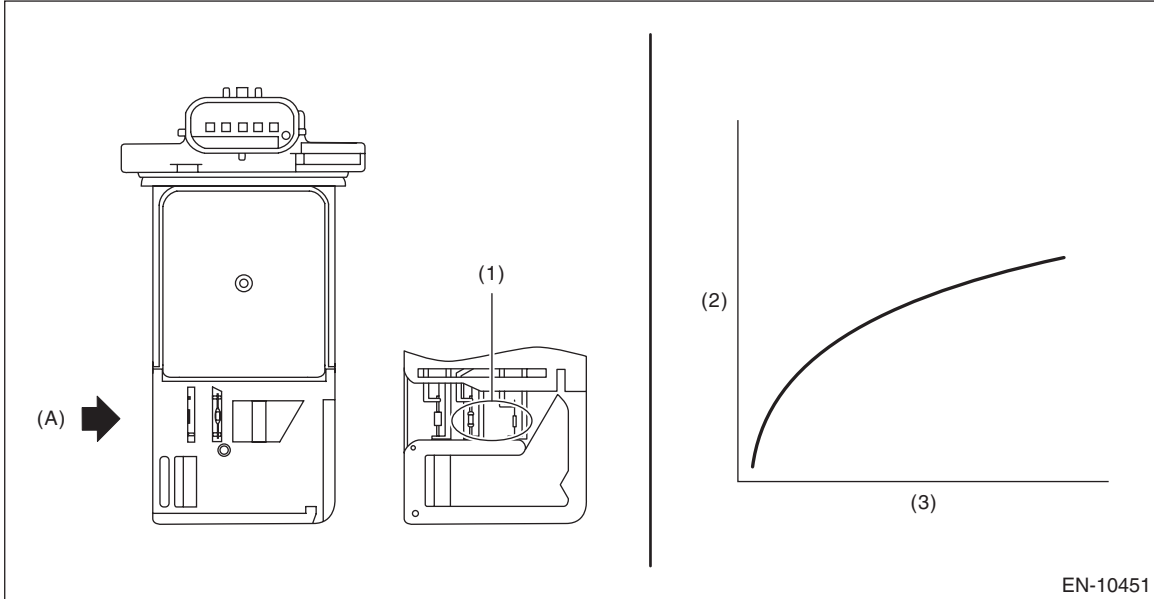

(A) Air

(1) Air flow sensor

(2) Voltage (V)

(3) Intake air amount (g (oz)/s)

#### 3. ENABLE CONDITIONS

Secondary Parameters	Enable Conditions
Elapsed time after ignition switch is turned to ON	$\geq 1040$ ms

#### 4. GENERAL DRIVING CYCLE

Always perform the diagnosis continuously.

#### 5. DIAGNOSTIC METHOD

If the duration of time while the following conditions are met is longer than the time indicated, judge as NG.

##### Judgment Value

Malfunction Criteria	Threshold Value
Output voltage	$> 4.79$ V

**Time Needed for Diagnosis:** 520 ms

**Malfunction Indicator Light Illumination:** Illuminates as soon as a malfunction occurs.



# Diagnostic Trouble Code (DTC) Detecting Criteria

GENERAL DESCRIPTION

## AP:DTC P0107 MANIFOLD ABSOLUTE PRESSURE/BAROMETRIC PRESSURE CIRCUIT LOW INPUT

### 1. OUTLINE OF DIAGNOSIS

Detect the open or short circuit of manifold absolute pressure sensor.

Judge as NG if out of specification.

### 2. COMPONENT DESCRIPTION

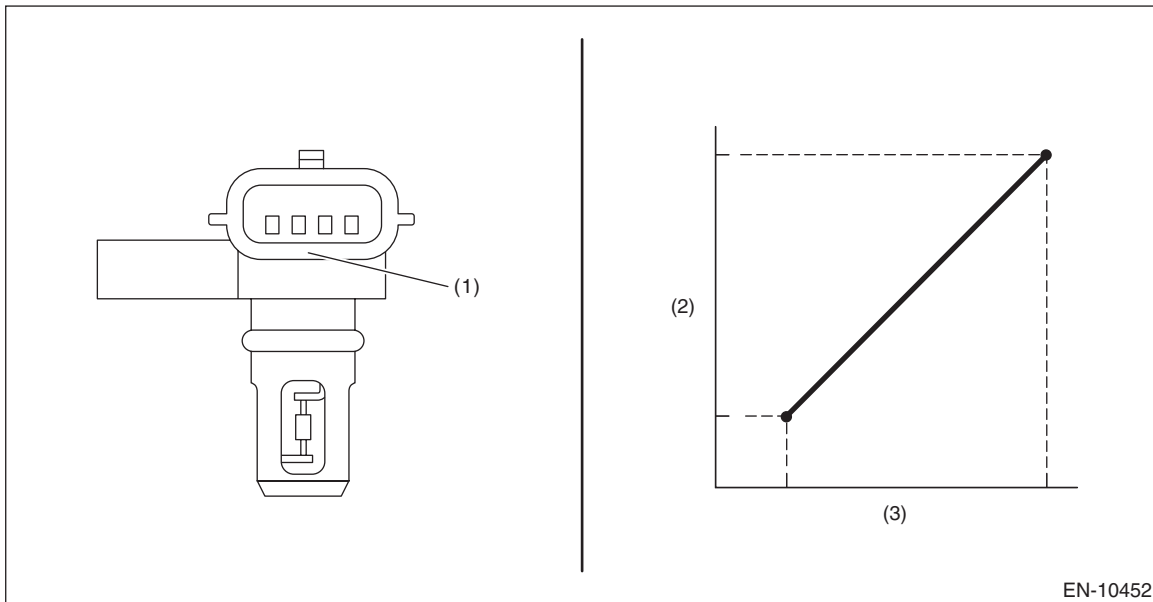

(1) Manifold absolute pressure sensor (2) Voltage (V)

(3) Absolute pressure (kPa)

### 3. ENABLE CONDITIONS

Secondary Parameters	Enable Conditions
None	

### 4. GENERAL DRIVING CYCLE

Always perform the diagnosis continuously.

### 5. DIAGNOSTIC METHOD

If the duration of time while the following conditions are met is longer than the time indicated, judge as NG.

#### Judgment Value

Malfunction Criteria	Threshold Value
Output voltage	< 0.36 V

**Time Needed for Diagnosis:** 2000 ms

**Malfunction Indicator Light Illumination:** Illuminates as soon as a malfunction occurs.

# Diagnostic Trouble Code (DTC) Detecting Criteria

## GENERAL DESCRIPTION

### AQ:DTC P0108 MANIFOLD ABSOLUTE PRESSURE/BAROMETRIC PRESSURE CIRCUIT HIGH INPUT

#### 1. OUTLINE OF DIAGNOSIS

Detect the open or short circuit of manifold absolute pressure sensor.  
Judge as NG if out of specification.

#### 2. COMPONENT DESCRIPTION

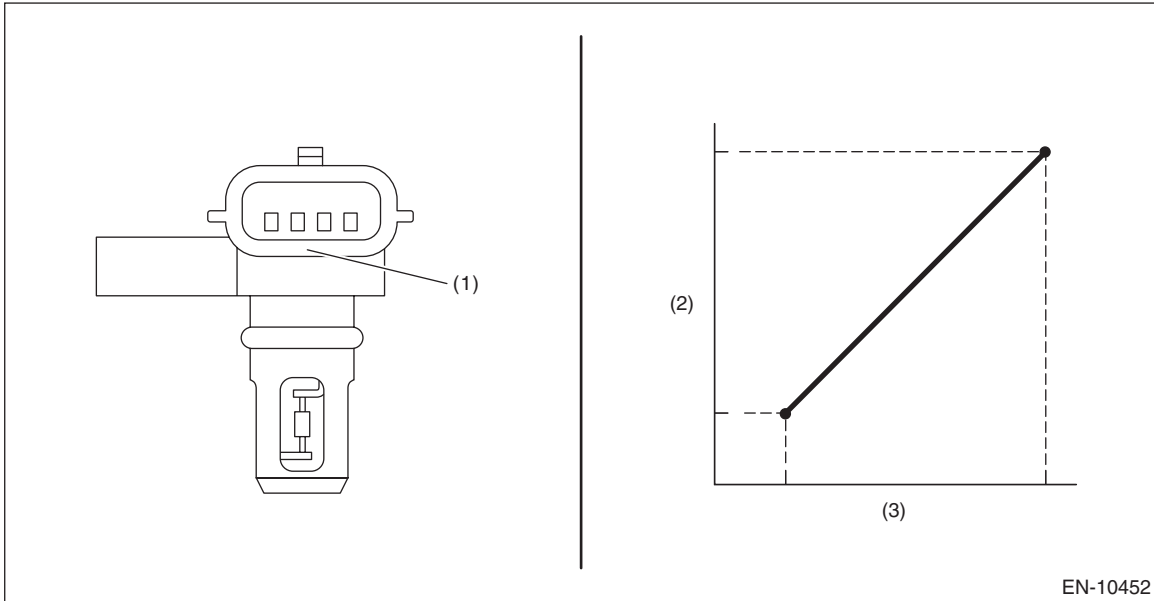

(1) Manifold absolute pressure sensor (2) Voltage (V)

(3) Absolute pressure (kPa)

#### 3. ENABLE CONDITIONS

Secondary Parameters	Enable Conditions
None	

#### 4. GENERAL DRIVING CYCLE

Always perform the diagnosis continuously.

#### 5. DIAGNOSTIC METHOD

If the duration of time while the following conditions are met is longer than the time indicated, judge as NG.

##### Judgment Value

Malfunction Criteria	Threshold Value
Output voltage	> 4.85 V

**Time Needed for Diagnosis:** 2000 ms

**Malfunction Indicator Light Illumination:** Illuminates as soon as a malfunction occurs.

## AR:DTC P0111 INTAKE AIR TEMPERATURE SENSOR RANGE/PERFORMANCE PROBLEM

### 1. OUTLINE OF DIAGNOSIS

Detect the malfunction of the intake air temperature sensor (integrated with air flow sensor) output properties. Using the following two diagnoses, judge as NG when either is NG.

- **Diagnosis 1 (correlation diagnosis):** After the engine starts after the specified period of soaking time has elapsed, diagnose by correlation between intake air temperature sensor value, engine coolant temperature sensor value and ambient temperature sensor value. Judge as NG when the differences are both above the specified value by comparing between intake air temperature and engine coolant temperature, intake air temperature and ambient air temperature.
- **Diagnosis 2 (stuck diagnosis):** Judge as NG when intake air temperature does not change under the driving condition where it should change, considering engine condition.

### 2. COMPONENT DESCRIPTION

Intake air temperature sensor (integrated with air flow sensor)

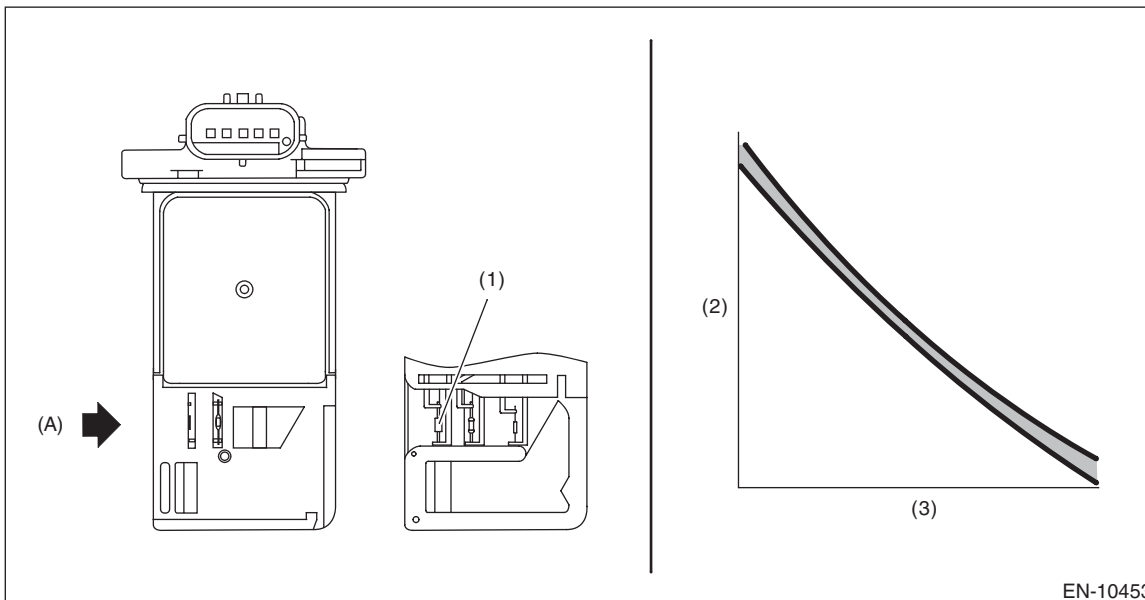

EN-10453

(A) Air

(1) Intake air temperature sensor

(2) Resistance value ( $\Omega$ )

(3) Intake air temperature  $^{\circ}\text{C}$  ( $^{\circ}\text{F}$ )

# Diagnostic Trouble Code (DTC) Detecting Criteria

## GENERAL DESCRIPTION

---

### 3. ENABLE CONDITIONS

#### Diagnosis 1

Secondary Parameters	Enable Conditions
Soaking time	≥ 21600 s
Block heater judgment	Completed
Block heater operation	Not in operation

#### Diagnosis 2

Secondary Parameters	Enable Conditions
Battery voltage	≥ 10.9 V
Engine coolant temperature	≥ 60°C (140°F)
Intake air amount sum value	≥ 6,500 g
Number of experiences under conditions below	≥ 3 times
• Continuous time when vehicle speed is less than 4 km/h (2.5 MPH)	≥ 24 s
• Continuous time when the vehicle speed is 40 km/h (24.9 MPH) or more, and intake air amount is 10 g/s (0.4 oz/s) or more	≥ 10 s

### 4. GENERAL DRIVING CYCLE

- **Diagnosis 1:** Perform the diagnosis only once after the engine starts after a certain period of soaking time.
- **Diagnosis 2:** Perform the diagnosis when the vehicle speed condition is met after warming up from a cold condition.

# Diagnostic Trouble Code (DTC) Detecting Criteria

GENERAL DESCRIPTION

## 5. DIAGNOSTIC METHOD

Judge as NG when Diagnosis 1 or Diagnosis 2 becomes NG.

### Diagnosis 1

If the duration of time while the following conditions are met is longer than the time indicated, judge as NG.

#### Judgment Value

Malfunction Criteria	Threshold Value
Intake air temperature (air flow sensor) 30 sec. after engine start – Engine coolant temperature at engine start	> Value of Map 1
Intake air temperature (air flow sensor) 30 sec. after engine start – Ambient air temperature 30 sec. after engine start	> Value of Map 2

#### Map 1

Ambient air temperature °C (°F)	-30 (-22)	30 (86)	45 (113)	60 (140)
Intake air temperature (air flow sensor) 30 sec. after engine start – Engine coolant temperature at engine start  °C (°F)	12 (21.6)	12 (21.6)	22 (39.6)	22 (39.6)

#### Map 2

Ambient air temperature °C (°F)	-30 (-22)	30 (86)	45 (113)	60 (140)
Intake air temperature (air flow sensor) 30 sec. after engine start – Ambient air temperature 30 sec. after engine start  °C (°F)	20 (36)	20 (36)	32 (57.6)	32 (57.6)

**Time Needed for Diagnosis:** Less than 1 second

### Diagnosis 2

Judge as NG when the following conditions are established.

#### Judgment Value

Malfunction Criteria	Threshold Value
Output voltage difference between Max. and Min.	< 0.02 V (Equivalent to approximately 0.5°C (0.9°F) near 25°C (77°F))

**Time Needed for Diagnosis:** Less than 1 second

**Malfunction Indicator Light Illumination:** Illuminates when malfunction occurs in 2 continuous driving cycles.

# Diagnostic Trouble Code (DTC) Detecting Criteria

## GENERAL DESCRIPTION

### AS:DTC P0112 INTAKE AIR TEMPERATURE SENSOR 1 CIRCUIT LOW

#### 1. OUTLINE OF DIAGNOSIS

Detect open or short circuit of the intake air temperature sensor (integrated with air flow sensor). Judge as NG if out of specification.

#### 2. COMPONENT DESCRIPTION

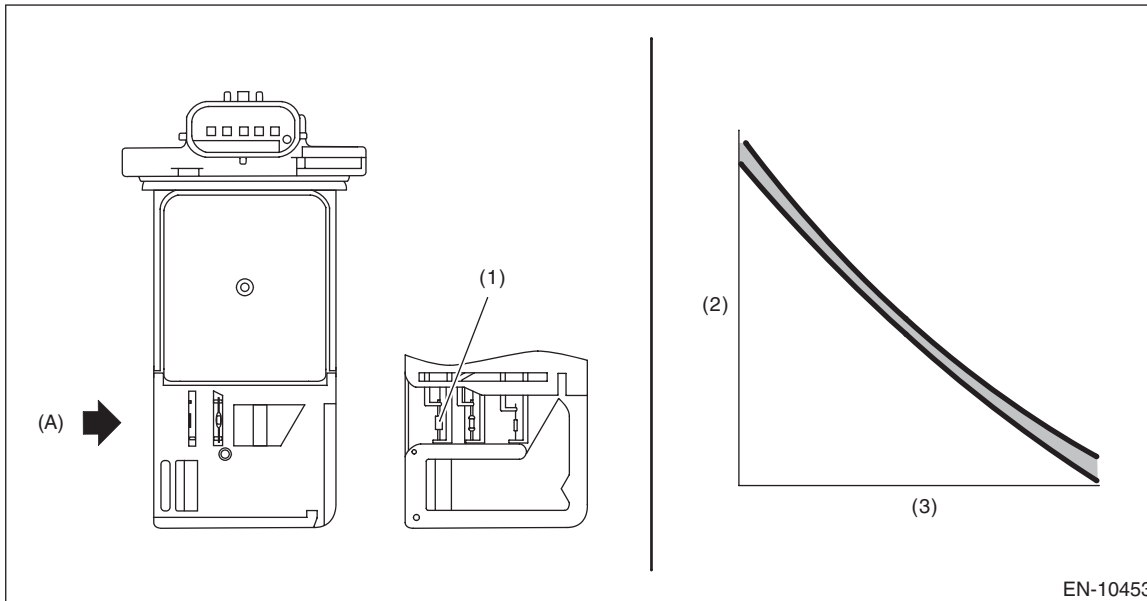

(A) Air

(1) Intake air temperature sensor

(2) Resistance value ( $\Omega$ )

(3) Intake air temperature  $^{\circ}\text{C}$  ( $^{\circ}\text{F}$ )

#### 3. ENABLE CONDITIONS

Secondary Parameters	Enable Conditions
None	

#### 4. GENERAL DRIVING CYCLE

Always perform the diagnosis continuously.

#### 5. DIAGNOSTIC METHOD

If the duration of time while the following conditions are met is longer than the time indicated, judge as NG.

##### Judgment Value

Malfunction Criteria	Threshold Value
Output voltage	< 0.22 V

**Time Needed for Diagnosis:** 520 ms

**Malfunction Indicator Light Illumination:** Illuminates as soon as a malfunction occurs.

# Diagnostic Trouble Code (DTC) Detecting Criteria

GENERAL DESCRIPTION

## AT:DTC P0113 INTAKE AIR TEMPERATURE SENSOR 1 CIRCUIT HIGH

### 1. OUTLINE OF DIAGNOSIS

Detect open or short circuit of the intake air temperature sensor (integrated with air flow sensor).  
Judge as NG if out of specification.

### 2. COMPONENT DESCRIPTION

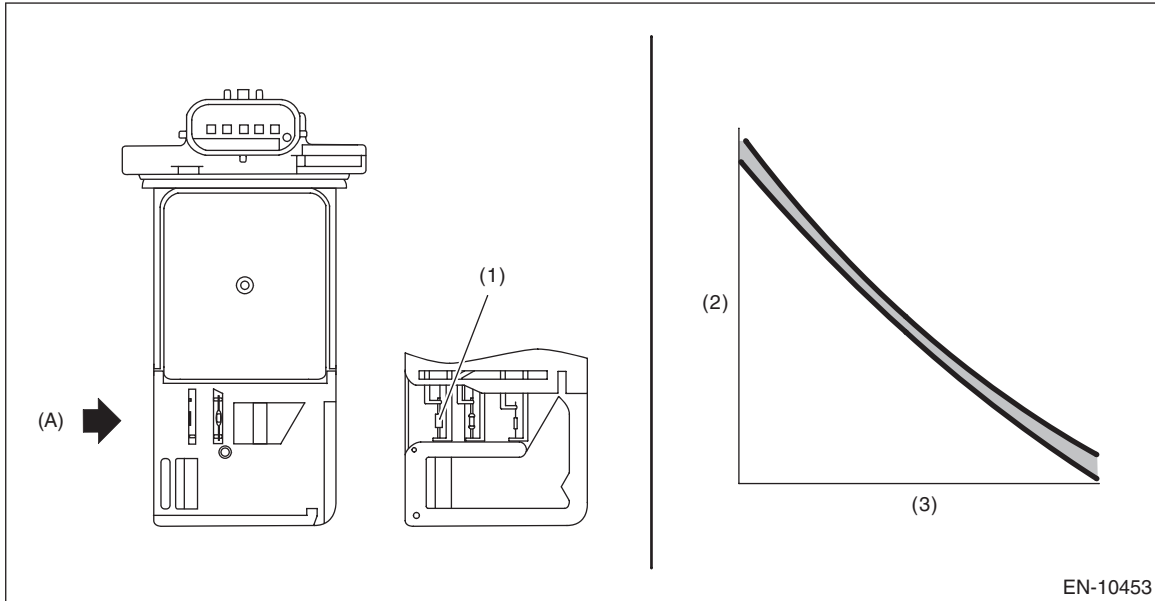

(A) Air

(1) Intake air temperature sensor

(2) Resistance value ( $\Omega$ )

(3) Intake air temperature  $^{\circ}\text{C}$  ( $^{\circ}\text{F}$ )

### 3. ENABLE CONDITIONS

Secondary Parameters	Enable Conditions
None	

### 4. GENERAL DRIVING CYCLE

Always perform the diagnosis continuously.

### 5. DIAGNOSTIC METHOD

If the duration of time while the following conditions are met is longer than the time indicated, judge as NG.

#### Judgment Value

Malfunction Criteria	Threshold Value
Output voltage	> 4.72 V

**Time Needed for Diagnosis:** 520 ms

**Malfunction Indicator Light Illumination:** Illuminates as soon as a malfunction occurs.

# Diagnostic Trouble Code (DTC) Detecting Criteria

## GENERAL DESCRIPTION

### AU:DTC P0116 ENGINE COOLANT TEMPERATURE SENSOR 1 CIRCUIT RANGE/PERFORMANCE

#### 1. OUTLINE OF DIAGNOSIS

Detect the malfunction of the engine coolant temperature sensor characteristics.

After the engine starts after the specified period of soaking time has elapsed, diagnose by correlation between engine coolant temperature sensor value, intake air temperature sensor value and ambient temperature sensor value. Judge as NG when the differences are both above the specified value by comparing between engine coolant temperature and ambient air temperature, engine coolant temperature and intake air temperature.

#### 2. COMPONENT DESCRIPTION

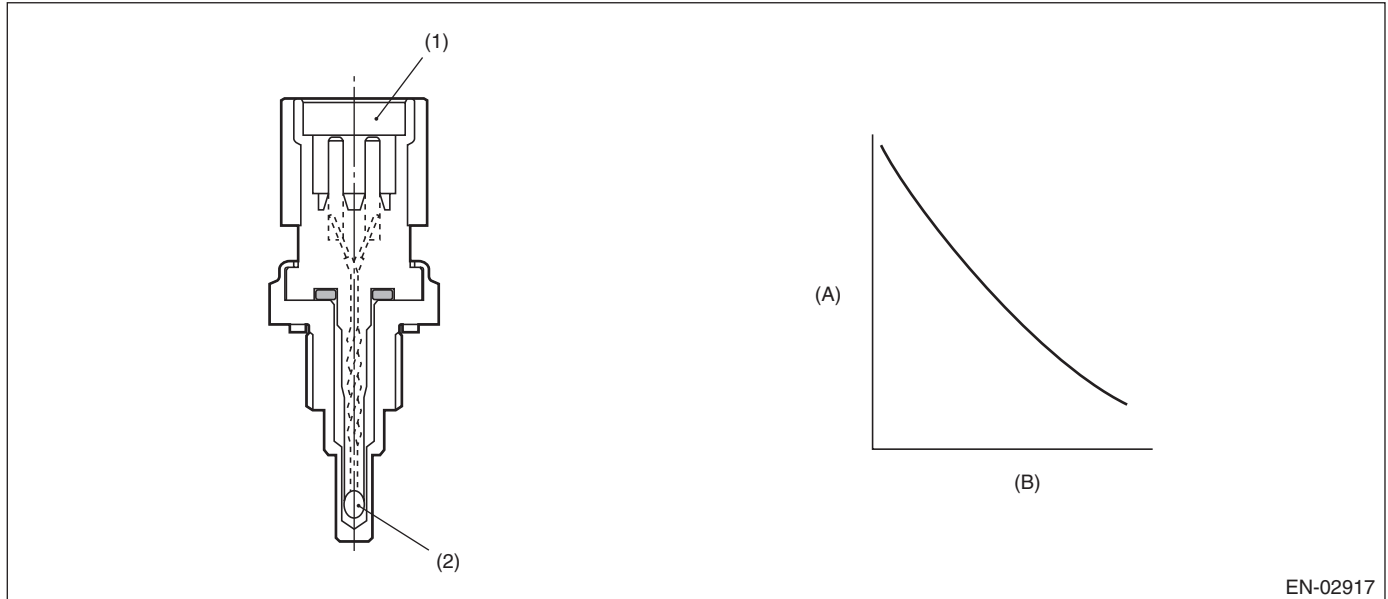

(A) Resistance value (k $\Omega$ )

(B) Temperature °C (°F)

(1) Connector

(2) Thermistor element

#### 3. ENABLE CONDITIONS

Secondary Parameters	Enable Conditions
Soaking time	$\geq 21600$ s
Block heater judgment	Completed
Block heater operation	Not in operation

#### 4. GENERAL DRIVING CYCLE

Perform the diagnosis only once after the engine starts after a certain period of soaking time.



# Diagnostic Trouble Code (DTC) Detecting Criteria

GENERAL DESCRIPTION

## 5. DIAGNOSTIC METHOD

Judge as NG when the following conditions are established.

### Judgment Value

Malfunction Criteria	Threshold Value
Engine coolant temperature at engine start – Intake air temperature 30 sec. after engine start	> Value from Map
Engine coolant temperature at engine start – Ambient air temperature at engine start	> 25°C (45°F)

### Map

Ambient air temperature °C (°F)	-30 (-22)	30 (86)	45 (113)	60 (140)
Engine coolant temperature at engine start – Intake air temperature 30 sec. after engine start  °C (°F)	12 (21.6)	12 (21.6)	22 (39.6)	22 (39.6)

**Time Needed for Diagnosis:** Less than 1 second

**Malfunction Indicator Light Illumination:** Illuminates when malfunction occurs in 2 continuous driving cycles.

# Diagnostic Trouble Code (DTC) Detecting Criteria

## GENERAL DESCRIPTION

### AV:DTC P0117 ENGINE COOLANT TEMPERATURE CIRCUIT LOW

#### 1. OUTLINE OF DIAGNOSIS

Detect the open or short circuit of the engine coolant temperature sensor.  
Judge as NG if out of specification.

#### 2. COMPONENT DESCRIPTION

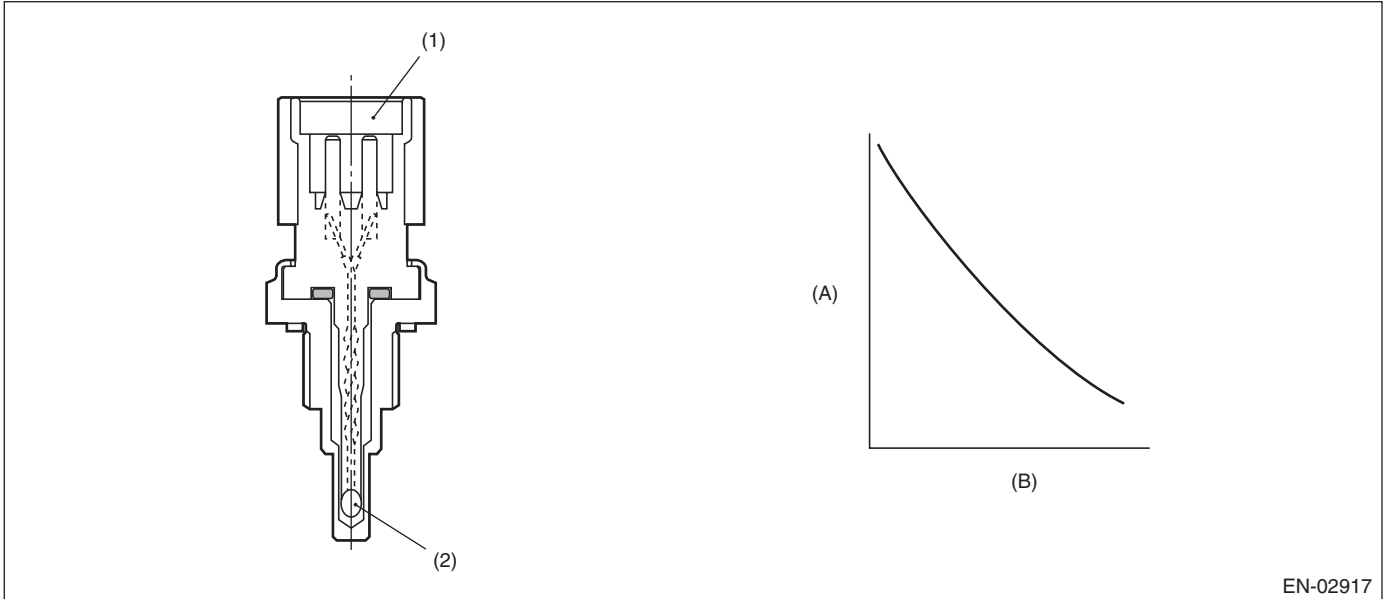

(A) Resistance value (k $\Omega$ )

(B) Temperature °C (°F)

(1) Connector

(2) Thermistor element

#### 3. ENABLE CONDITIONS

Secondary Parameters	Enable Conditions
None	

#### 4. GENERAL DRIVING CYCLE

Always perform the diagnosis continuously.

#### 5. DIAGNOSTIC METHOD

If the duration of time while the following conditions are met is longer than the time indicated, judge as NG.

##### Judgment Value

Malfunction Criteria	Threshold Value
Output voltage	< 0.33 V

**Time Needed for Diagnosis:** 500 ms

**Malfunction Indicator Light Illumination:** Illuminates as soon as a malfunction occurs.

# Diagnostic Trouble Code (DTC) Detecting Criteria

GENERAL DESCRIPTION

## AW:DTC P0118 ENGINE COOLANT TEMPERATURE CIRCUIT HIGH

### 1. OUTLINE OF DIAGNOSIS

Detect the open or short circuit of the engine coolant temperature sensor.  
Judge as NG if out of specification.

### 2. COMPONENT DESCRIPTION

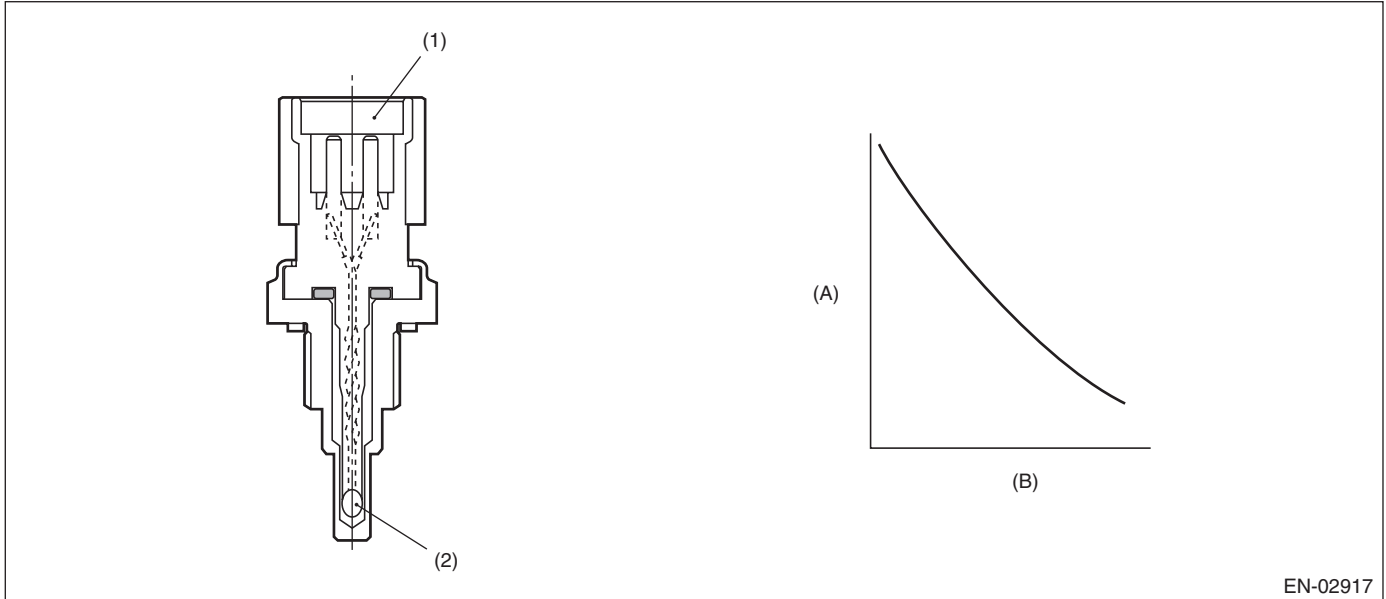

(A) Resistance value (k $\Omega$ )

(B) Temperature °C (°F)

(1) Connector

(2) Thermistor element

### 3. ENABLE CONDITIONS

Secondary Parameters	Enable Conditions
None	

### 4. GENERAL DRIVING CYCLE

Always perform the diagnosis continuously.

### 5. DIAGNOSTIC METHOD

If the duration of time while the following conditions are met is longer than the time indicated, judge as NG.

#### Judgment Value

Malfunction Criteria	Threshold Value
Output voltage	> 4.71 V

**Time Needed for Diagnosis:** 500 ms

**Malfunction Indicator Light Illumination:** Illuminates as soon as a malfunction occurs.

# Diagnostic Trouble Code (DTC) Detecting Criteria

## GENERAL DESCRIPTION

### AX:DTC P0122 THROTTLE/PEDAL POSITION SENSOR/SWITCH "A" CIRCUIT LOW

#### 1. OUTLINE OF DIAGNOSIS

Detect the open or short circuit of throttle position sensor 1.  
Judge as NG if out of specification.

#### 2. COMPONENT DESCRIPTION

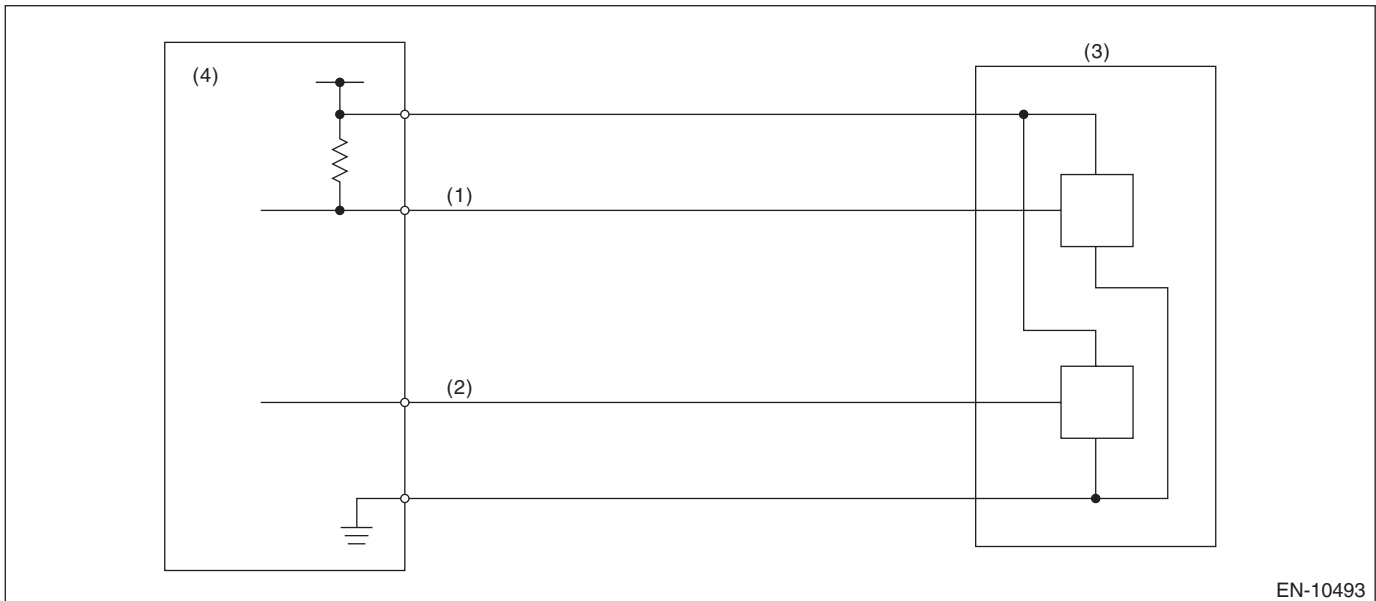

EN-10493

- (1) Throttle position sensor 1 signal      (3) Throttle position sensor      (4) Engine control module (ECM)  
(2) Throttle position sensor 2 signal

#### 3. ENABLE CONDITIONS

Secondary Parameters	Enable Conditions
Battery voltage	$\geq 6 \text{ V}$

#### 4. GENERAL DRIVING CYCLE

Always perform the diagnosis continuously.

#### 5. DIAGNOSTIC METHOD

If the duration of time while the following conditions are met is longer than the time indicated, judge as NG.

##### Judgment Value

Malfunction Criteria	Threshold Value
Sensor 1 input voltage	$< 0.29 \text{ V}$

**Time Needed for Diagnosis:** 100 ms

**Malfunction Indicator Light Illumination:** Illuminates as soon as a malfunction occurs.

# Diagnostic Trouble Code (DTC) Detecting Criteria

GENERAL DESCRIPTION

## AY:DTC P0123 THROTTLE/PEDAL POSITION SENSOR/SWITCH "A" CIRCUIT HIGH

### 1. OUTLINE OF DIAGNOSIS

Detect the open or short circuit of throttle position sensor 1.  
Judge as NG if out of specification.

### 2. COMPONENT DESCRIPTION

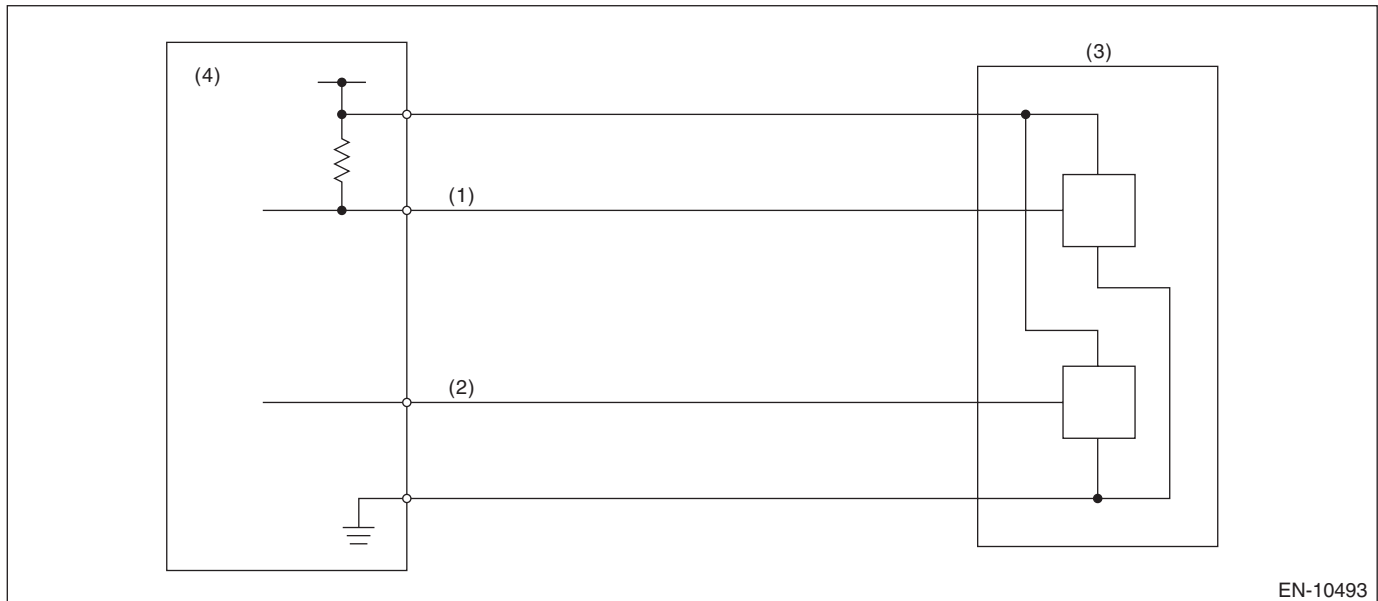

EN-10493

- (1) Throttle position sensor 1 signal      (3) Throttle position sensor      (4) Engine control module (ECM)  
(2) Throttle position sensor 2 signal

### 3. ENABLE CONDITIONS

Secondary Parameters	Enable Conditions
Battery voltage	$\geq 6 \text{ V}$

### 4. GENERAL DRIVING CYCLE

Always perform the diagnosis continuously.

### 5. DIAGNOSTIC METHOD

If the duration of time while the following conditions are met is longer than the time indicated, judge as NG.

#### Judgment Value

Malfunction Criteria	Threshold Value
Sensor 1 input voltage	$> 4.69 \text{ V}$

**Time Needed for Diagnosis:** 100 ms

**Malfunction Indicator Light Illumination:** Illuminates as soon as a malfunction occurs.

# Diagnostic Trouble Code (DTC) Detecting Criteria

## GENERAL DESCRIPTION

### AZ:DTC P0125 INSUFFICIENT COOLANT TEMPERATURE FOR CLOSED LOOP FUEL CONTROL

#### 1. OUTLINE OF DIAGNOSIS

Detect the malfunction of engine coolant temperature output property.

Judge as NG when engine coolant temperature does not rise to the specified value after predetermined time has elapsed since engine start.

#### 2. COMPONENT DESCRIPTION

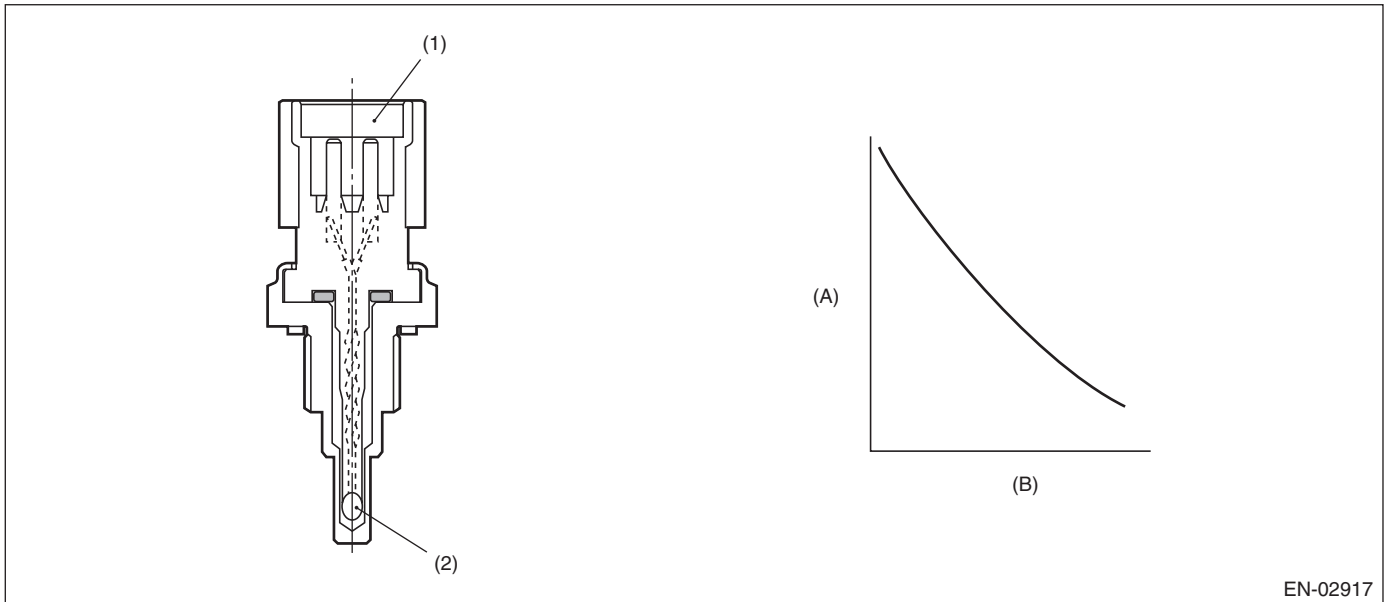

EN-02917

(A) Resistance value (k $\Omega$ )

(B) Temperature °C (°F)

(1) Connector

(2) Thermistor element

#### 3. ENABLE CONDITIONS

Secondary Parameters	Enable Conditions
Engine coolant temperature at engine start	< -15°C (5°F)
Engine speed	> 475 rpm

#### 4. GENERAL DRIVING CYCLE

Perform the diagnosis only once after starting the engine from cold condition.

# Diagnostic Trouble Code (DTC) Detecting Criteria

GENERAL DESCRIPTION

## 5. DIAGNOSTIC METHOD

If the duration of time while the following conditions are met is longer than the time indicated, judge as NG.

### Judgment Value

Malfunction Criteria	Threshold Value
Engine coolant temperature	< -15°C (5°F)
Elapsed time after starting the engine ((Smaller value either one of engine coolant temperature and intake air temperature at engine start) ≥ -23.3°C (-9.9°F))	≥ 120 s
or	
Elapsed time after starting the engine ((Smaller value either one of engine coolant temperature and intake air temperature at engine start) < -23.3°C (-9.9°F))	≥ 300 s

**Time Needed for Diagnosis:** 120 or 300 seconds

**Malfunction Indicator Light Illumination:** Illuminates when malfunction occurs in 2 continuous driving cycles.

# Diagnostic Trouble Code (DTC) Detecting Criteria

## GENERAL DESCRIPTION

### BA:DTC P0128 COOLANT THERMOSTAT (ENGINE COOLANT TEMPERATURE BELOW THERMOSTAT REGULATING TEMPERATURE)

#### 1. OUTLINE OF DIAGNOSIS

Detect malfunctions of the thermostat function.

Judge as NG when any one of the following conditions is established.

- When the actual engine coolant temperature does not reach the maximum temperature necessary to perform other OBDII diagnosis and  $\Sigma$  (Estimated engine coolant temperature – actual engine coolant temperature) exceeded the predetermined value. (Judgment 1)
- When the actual engine coolant temperature does not reach the range within  $-11^{\circ}\text{C}$  ( $-19.8^{\circ}\text{F}$ ) from the regulated temperature and  $\Sigma$  (Estimated engine coolant temperature – actual engine coolant temperature) exceeded the predetermined value. (Judgment 2)
- When the difference between the estimated coolant temperature and the actual engine coolant temperature exceeds the predetermined value, and  $\Sigma$  (Estimated engine coolant temperature – actual engine coolant temperature) exceeded the predetermined value. (Judgment 3)

#### 2. COMPONENT DESCRIPTION

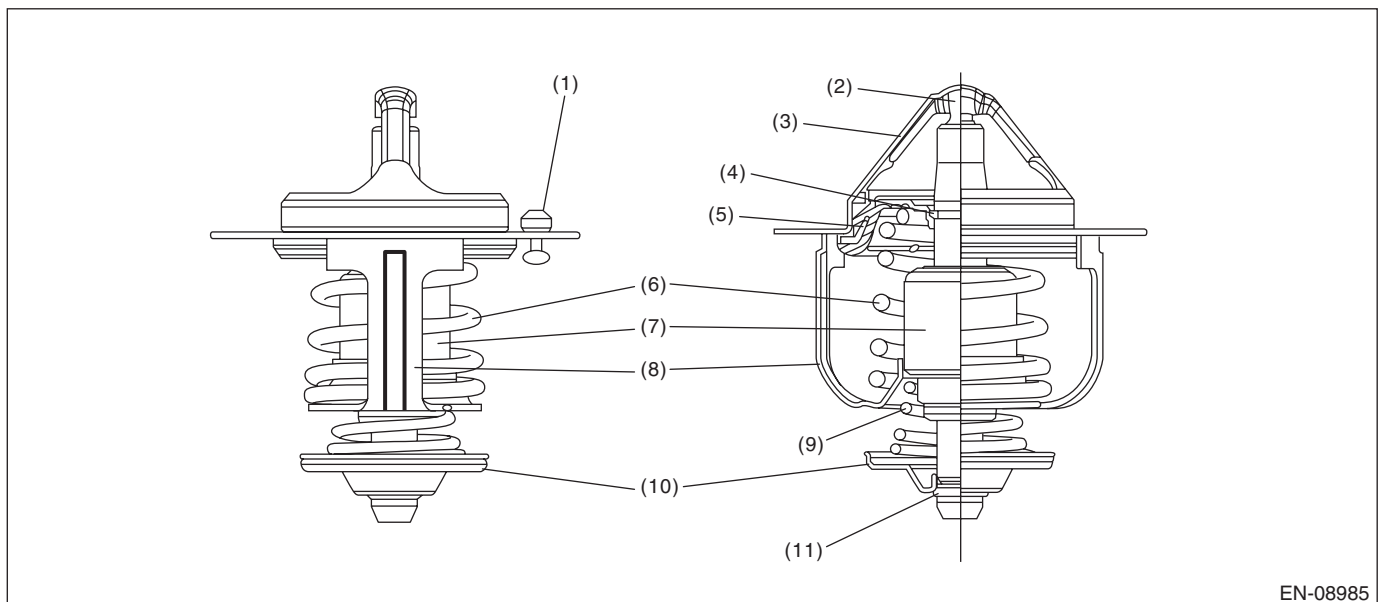

EN-08985

- |                  |                 |                   |
|------------------|-----------------|-------------------|
| (1) Jiggle valve | (5) Dust seal   | (9) Bypass spring |
| (2) Piston       | (6) Main spring | (10) Bypass valve |
| (3) Flange       | (7) Wax element | (11) Stop ring    |
| (4) Stop ring    | (8) Frame       |                   |



# Diagnostic Trouble Code (DTC) Detecting Criteria

GENERAL DESCRIPTION

## 3. ENABLE CONDITIONS

Secondary Parameters	Enable Conditions
<Judgment 1>	
Battery voltage	≥ 10.9 V
Estimate ambient temperature	≥ -7°C (19.4°F)
Vehicle speed	≥ 30 km/h (18.6 MPH)
Estimated coolant temperature	> 60°C (140°F)
Coolant temperature at engine starting	< 60°C (140°F)
<Judgment 2>	
Battery voltage	≥ 10.9 V
Estimate ambient temperature	≥ -7°C (19.4°F)
Vehicle speed	≥ 30 km/h (18.6 MPH)
Estimated coolant temperature	> Value of Map 1
Coolant temperature at engine starting	< 60°C (140°F)
<Judgment 3>	
Battery voltage	≥ 10.9 V
Estimate ambient temperature	≥ -7°C (19.4°F)
Vehicle speed	≥ 30 km/h (18.6 MPH)
Estimated coolant temperature	≥ Value from Map 2
Coolant temperature at engine starting	< 60°C (140°F)

### Map 1

Engine coolant temperature at engine starting °C (°F)	-7 (19.4)	8 (46.4)	10 (50)	25 (77)
Estimated coolant temperature °C (°F)	70.6 (159.1)	78.1 (172.6)	78.1 (172.6)	78.1 (172.6)

### Map 2

Engine coolant temperature at engine starting °C (°F)	-7 (19.4)	10 (50)	25 (77)	31.8 (89.2)
Estimated coolant temperature °C (°F)	55 (131)	65.1 (149.2)	74 (165.2)	78.1 (172.6)

## 4. GENERAL DRIVING CYCLE

Perform the diagnosis only once after starting the engine.

# Diagnostic Trouble Code (DTC) Detecting Criteria

## GENERAL DESCRIPTION

### 5. DIAGNOSTIC METHOD

If the duration of time while the following conditions are met is longer than the time indicated, judge as NG.

#### Judgment Value

Malfunction Criteria	Threshold Value
When any one of the followings is established:	
<Judgment 1>	
Actual engine coolant temperature and $\Sigma$ (Estimated engine coolant temperature – actual engine coolant temperature)	< 60°C (140°F) > Value of Map 3
<Judgment 2>	
Actual engine coolant temperature and $\Sigma$ (Estimated engine coolant temperature – actual engine coolant temperature)	< Regulated temperature – Value of Map 4 > Value of Map 5
<Judgment 3>	
Estimated engine coolant temperature – actual engine coolant temperature and $\Sigma$ (Estimated engine coolant temperature – actual engine coolant temperature)	> 11.1°C (20°F) > Value of Map 6

#### Map 3

Engine coolant temperature at engine starting °C (°F)	-7 (19.4)	0 (32)	10 (50)	25 (77)	30 (86)	40 (104)
Threshold Value °C (°F)	1387.5 (2497.5)	1387.5 (2497.5)	1387.5 (2497.5)	1387.5 (2497.5)	1387.5 (2497.5)	961.5 (1730.7)

#### Map 4

Estimate ambient temperature °C (°F)	-7 (19.4)	8 (46.4)	10 (50)	25 (77)
Threshold Value °C (°F)	18.6 (33.5)	11.1 (20)	11.1 (20)	11.1 (20)

#### Map 5

Engine coolant temperature at engine starting °C (°F)	-7 (19.4)	0 (32)	8 (46.4)	10 (50)	30 (86)	35 (95)
Threshold Value °C (°F)	1387.5 (2497.5)	1387.5 (2497.5)	1387.5 (2497.5)	1387.5 (2497.5)	1387.5 (2497.5)	1201.9 (2163.4)

#### Map 6

Engine coolant temperature at engine starting °C (°F)	-7 (19.4)	8 (46.4)	10 (50)	25 (77)
Threshold Value °C (°F)	1387.5 (2497.5)	1387.5 (2497.5)	1387.5 (2497.5)	1387.5 (2497.5)

**Time Needed for Diagnosis:** Less than 1 second

**Malfunction Indicator Light Illumination:** Illuminates when malfunction occurs in 2 continuous driving cycles.

# Diagnostic Trouble Code (DTC) Detecting Criteria

GENERAL DESCRIPTION

## BB:DTC P0130 O2 SENSOR CIRCUIT (BANK 1 SENSOR 1)

### 1. OUTLINE OF DIAGNOSIS

Judge as NG, while the element impedance is low with the element current out of the range.

### 2. COMPONENT DESCRIPTION

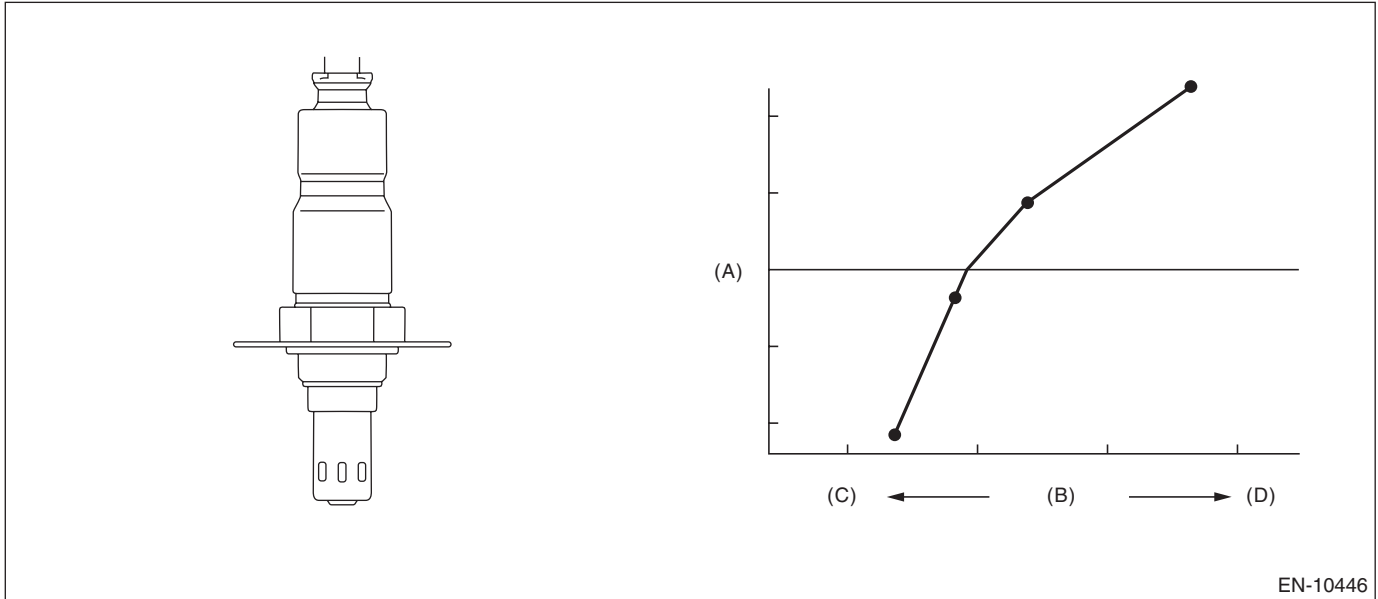

(A) Electromotive force  
(D) Lean

(B) Air fuel ratio

(C) Rich

### 3. ENABLE CONDITIONS

Secondary Parameters	Enable Conditions
Battery voltage	$\geq 10.9 \text{ V}$
Engine speed	$\geq 500 \text{ rpm}$
Front oxygen (A/F) sensor impedance	$\leq 403 \Omega$

### 4. GENERAL DRIVING CYCLE

Always perform the diagnosis continuously.

### 5. DIAGNOSTIC METHOD

If the duration of time while the following conditions are met is longer than the time indicated, judge as NG.

#### Judgment Value

Malfunction Criteria	Threshold Value
Input current	$< -45 \mu\text{A}$ or $> 45 \mu\text{A}$

**Time Needed for Diagnosis:** 3040 ms

**Malfunction Indicator Light Illumination:** Illuminates as soon as a malfunction occurs.

# Diagnostic Trouble Code (DTC) Detecting Criteria

## GENERAL DESCRIPTION

### BC:DTC P0131 O2 SENSOR CIRCUIT LOW VOLTAGE (BANK 1 SENSOR 1)

#### 1. OUTLINE OF DIAGNOSIS

Detect the open or short circuit of sensor.

Judge as NG, when the element voltage is out of the specified range.

#### 2. COMPONENT DESCRIPTION

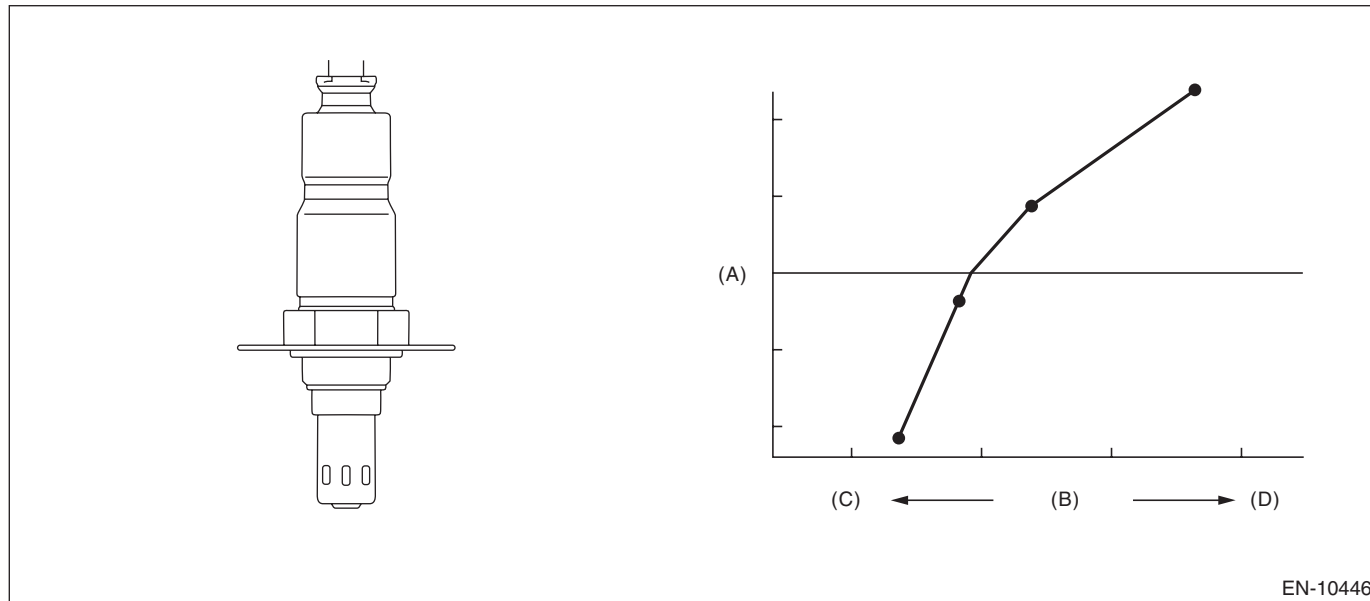

(A) Electromotive force  
(D) Lean

(B) Air fuel ratio

(C) Rich

#### 3. ENABLE CONDITIONS

Secondary Parameters	Enable Conditions
Battery voltage	$\geq 10.9 \text{ V}$
Engine speed	$\geq 500 \text{ rpm}$

#### 4. GENERAL DRIVING CYCLE

Always perform the diagnosis continuously.

#### 5. DIAGNOSTIC METHOD

If the duration of time while the following conditions are met is longer than the time indicated, judge as NG.

##### Judgment Value

Malfunction Criteria	Threshold Value
Input voltage (+) or Input voltage (-) or Sensor reference voltage	$\leq 1 \text{ V}$

**Time Needed for Diagnosis:** 560 ms

**Malfunction Indicator Light Illumination:** Illuminates as soon as a malfunction occurs.

# Diagnostic Trouble Code (DTC) Detecting Criteria

GENERAL DESCRIPTION

## BD:DTC P0132 O2 SENSOR CIRCUIT HIGH VOLTAGE (BANK 1 SENSOR 1)

### 1. OUTLINE OF DIAGNOSIS

Detect the open or short circuit of sensor.

Judge as NG, when the element voltage is out of the specified range.

### 2. COMPONENT DESCRIPTION

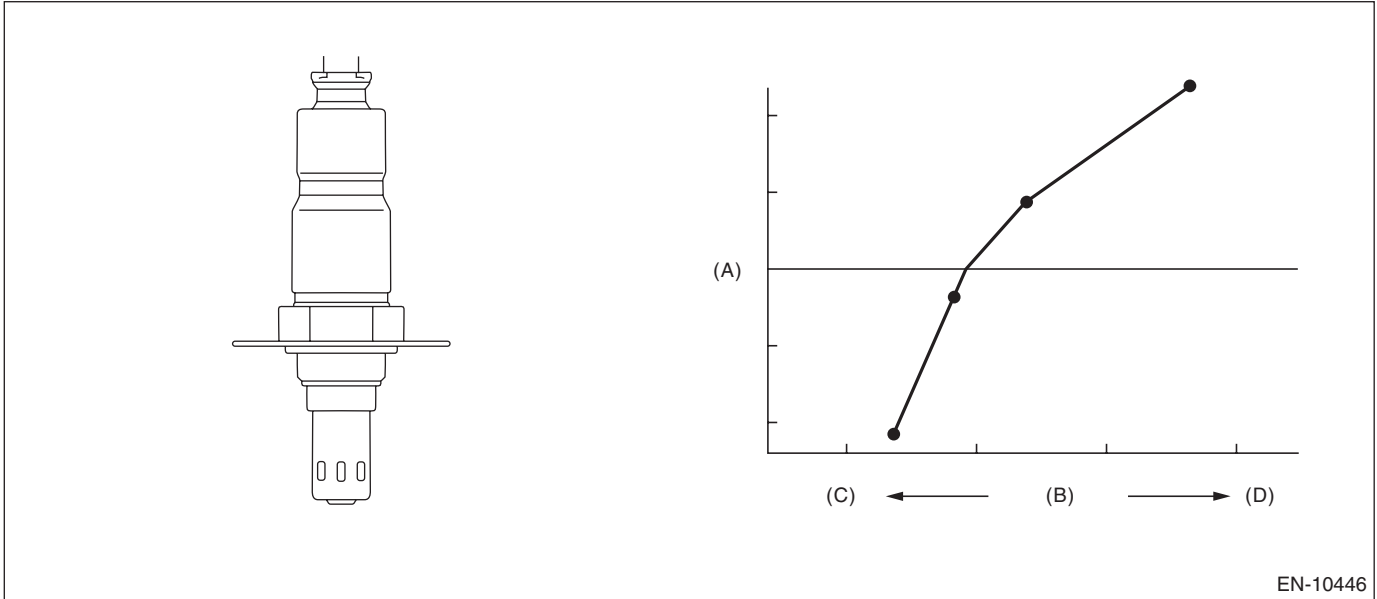

EN-10446

(A) Electromotive force

(B) Air fuel ratio

(C) Rich

(D) Lean

### 3. ENABLE CONDITIONS

Secondary Parameters	Enable Conditions
Battery voltage	$\geq 10.9 \text{ V}$
Engine speed	$\geq 500 \text{ rpm}$

### 4. GENERAL DRIVING CYCLE

Always perform the diagnosis continuously.

### 5. DIAGNOSTIC METHOD

If the duration of time while the following conditions are met is longer than the time indicated, judge as NG.

#### Judgment Value

Malfunction Criteria	Threshold Value
Input voltage (+)	$\geq \text{Battery voltage} - 1 \text{ V}$
or	
Input voltage (-)	$\geq \text{Battery voltage} - 1 \text{ V}$
or	
Sensor reference voltage	$\geq 6.5 \text{ V}$

**Time Needed for Diagnosis:** 560 ms

**Malfunction Indicator Light Illumination:** Illuminates as soon as a malfunction occurs.

# Diagnostic Trouble Code (DTC) Detecting Criteria

## GENERAL DESCRIPTION

### BE:DTC P0134 O2 SENSOR CIRCUIT NO ACTIVITY DETECTED (BANK 1 SENSOR 1)

#### 1. OUTLINE OF DIAGNOSIS

Detect open circuits of the sensor.

Judge as NG when the element voltage is out of range, or the element current is stuck.

#### 2. COMPONENT DESCRIPTION

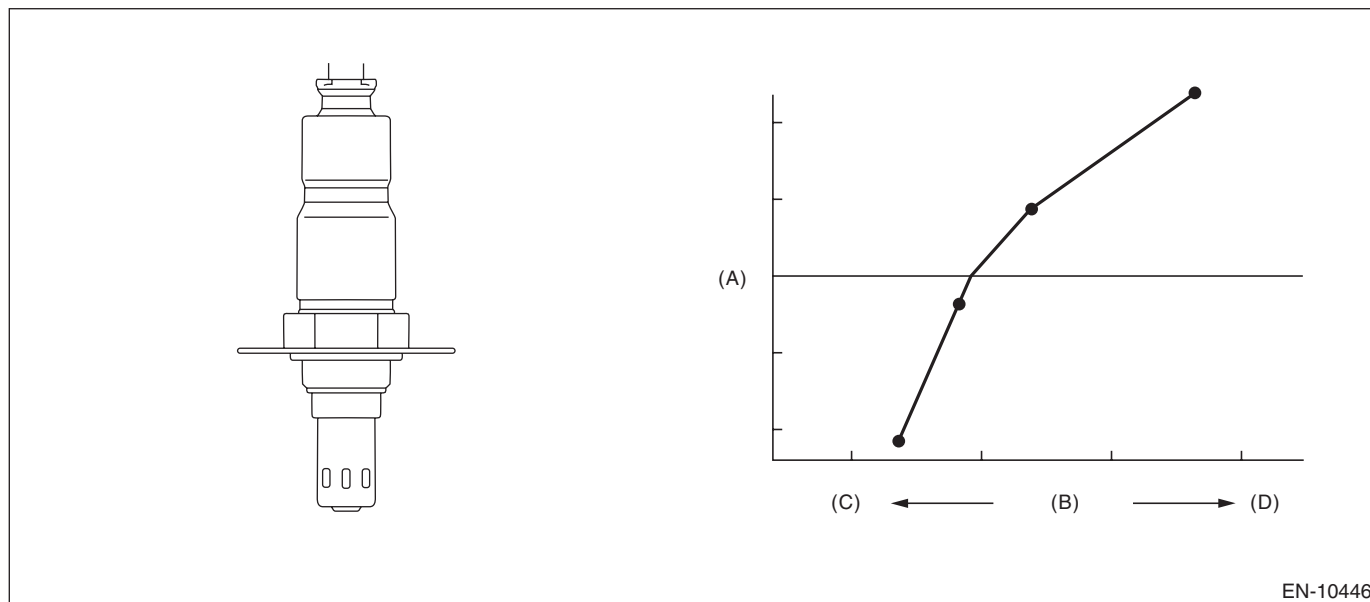

(A) Electromotive force

(B) Air fuel ratio

(C) Rich

(D) Lean

#### 3. ENABLE CONDITIONS

Secondary Parameters	Enable Conditions
Battery voltage	$\geq 10.9 \text{ V}$
Engine speed	$\geq 500 \text{ rpm}$
<When out of range> Front oxygen (A/F) sensor impedance	$> 403 \Omega$
<When stuck> Front oxygen (A/F) sensor impedance	$\leq 403 \Omega$

#### 4. GENERAL DRIVING CYCLE

Always perform the diagnosis continuously.

# Diagnostic Trouble Code (DTC) Detecting Criteria

GENERAL DESCRIPTION

## 5. DIAGNOSTIC METHOD

If the duration of time while the following conditions are met is longer than the time indicated, judge as NG.

### Judgment Value

Malfunction Criteria	Threshold Value
Input voltage (+)	> 2.65 V
or	
Sensor reference voltage	$\leq 3.6$ V
or	
Input current	-45 $\mu$ A — 45 $\mu$ A

### Time Needed for Diagnosis:

Input voltage (+): 30000 ms

Sensor reference voltage: 2000 ms

Input current: 2000 ms

**Malfunction Indicator Light Illumination:** Illuminates as soon as a malfunction occurs.

# Diagnostic Trouble Code (DTC) Detecting Criteria

## GENERAL DESCRIPTION

### BF:DTC P0137 O2 SENSOR CIRCUIT LOW VOLTAGE (BANK 1 SENSOR 2)

#### 1. OUTLINE OF DIAGNOSIS

Detect continuity NG of the oxygen sensor. Judge as NG when the oxygen sensor voltage reading is not within the probable range.

#### 2. COMPONENT DESCRIPTION

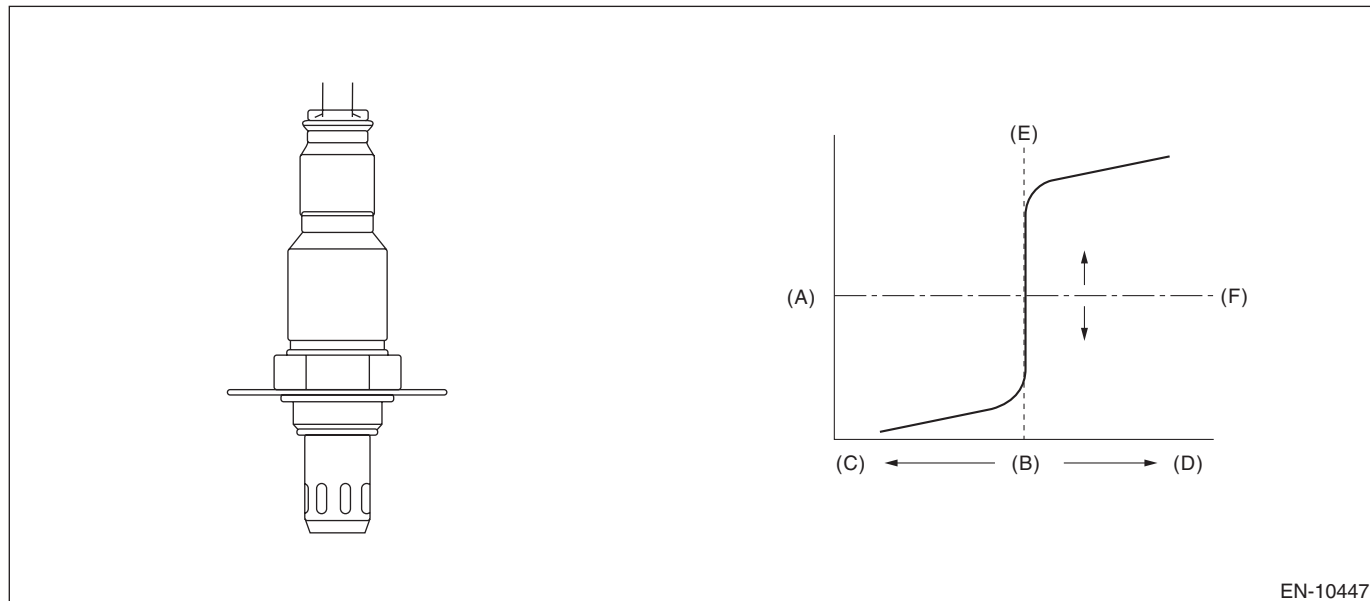

EN-10447

(A) Electromotive force

(B) Air fuel ratio

(C) Lean

(D) Rich

(E) Theoretical air fuel ratio

(F) Comparative voltage

#### 3. ENABLE CONDITIONS

Secondary Parameters	Enable Conditions
Battery voltage	$\geq 10.9 \text{ V}$

#### 4. GENERAL DRIVING CYCLE

Always perform the diagnosis continuously after the enable conditions have been established.

#### 5. DIAGNOSTIC METHOD

If the duration of time while the following conditions are met is longer than the time indicated, judge as NG.

##### Judgment Value

Malfunction Criteria	Threshold Value
Oxygen sensor offset voltage	$< 1.7 \text{ V}$

**Time Needed for Diagnosis:** 1 second

**Malfunction Indicator Light Illumination:** Illuminates when malfunction occurs in 2 continuous driving cycles.



# Diagnostic Trouble Code (DTC) Detecting Criteria

GENERAL DESCRIPTION

## BG:DTC P0138 O2 SENSOR CIRCUIT HIGH VOLTAGE (BANK 1 SENSOR 2)

### 1. OUTLINE OF DIAGNOSIS

Detect continuity NG of the oxygen sensor. Judge as NG when the oxygen sensor voltage reading is not within the probable range.

### 2. COMPONENT DESCRIPTION

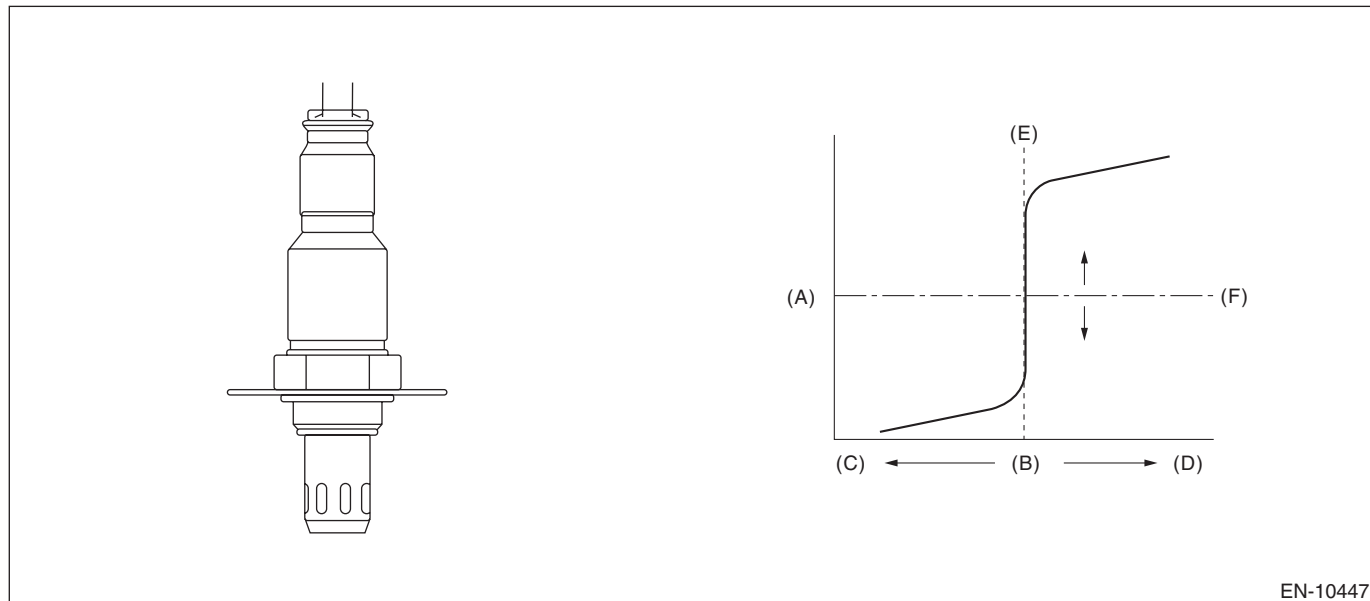

EN-10447

(A) Electromotive force

(B) Air fuel ratio

(C) Lean

(D) Rich

(E) Theoretical air fuel ratio

(F) Comparative voltage

### 3. ENABLE CONDITIONS

Secondary Parameters	Enable Conditions
Battery voltage	$\geq 10.9 \text{ V}$

### 4. GENERAL DRIVING CYCLE

Always perform the diagnosis continuously after the enable conditions have been established.

### 5. DIAGNOSTIC METHOD

If the duration of time while the following conditions are met is longer than the time indicated, judge as NG.

#### Judgment Value

Malfunction Criteria	Threshold Value
Oxygen sensor offset voltage or Oxygen sensor voltage	$> 2.3 \text{ V}$  $> 3.3 \text{ V}$

**Time Needed for Diagnosis:** 1 second

**Malfunction Indicator Light Illumination:** Illuminates when malfunction occurs in 2 continuous driving cycles.

# Diagnostic Trouble Code (DTC) Detecting Criteria

## GENERAL DESCRIPTION

### BH:DTC P013A O2 SENSOR SLOW RESPONSE - RICH TO LEAN (BANK 1 SENSOR 2)

#### 1. OUTLINE OF DIAGNOSIS

Detect the slow response of rich → lean for rear oxygen sensor output.

When the deceleration fuel cut has occurred, detect the trouble by calculating the time when the rear oxygen sensor output passes through the predetermined range of voltages.

Judge as NG when the response time is larger than the threshold value.

#### 2. COMPONENT DESCRIPTION

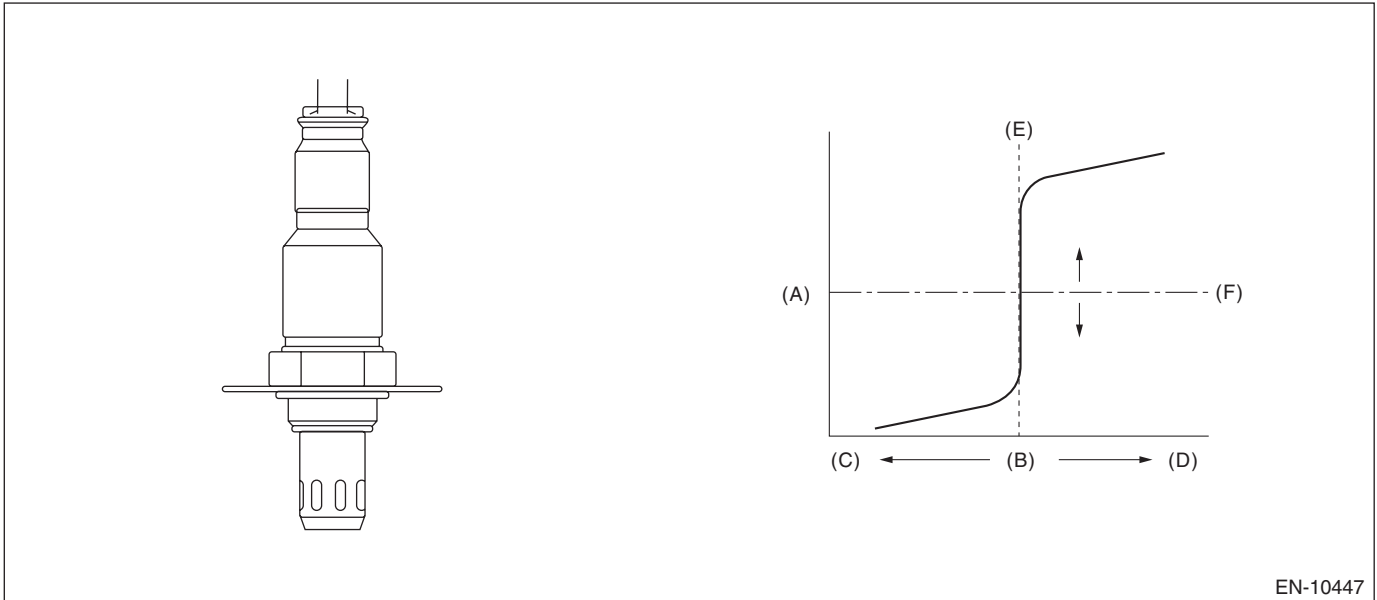

EN-10447

(A) Electromotive force

(B) Air fuel ratio

(C) Lean

(D) Rich

(E) Theoretical air fuel ratio

(F) Comparative voltage

#### 3. ENABLE CONDITIONS

Secondary Parameters	Enable Conditions
Battery voltage	≥ 10.9 V
Current calculation time of the rear oxygen sensor heater after starting	≥ 180000 ms
Rear oxygen sensor voltage when fuel cut starts	≥ 0.55 V
Fuel cut	In operation
Estimated temperature of rear oxygen sensor element when fuel cut starts	≥ 450°C (842°F)

#### 4. GENERAL DRIVING CYCLE

Perform diagnosis once during deceleration fuel cut from a constant and high speed driving, when rear oxygen sensor is warmed up sufficiently.

# Diagnostic Trouble Code (DTC) Detecting Criteria

GENERAL DESCRIPTION

## 5. DIAGNOSTIC METHOD

Detect the trouble by calculating the response time of the rear oxygen sensor during fuel cut.

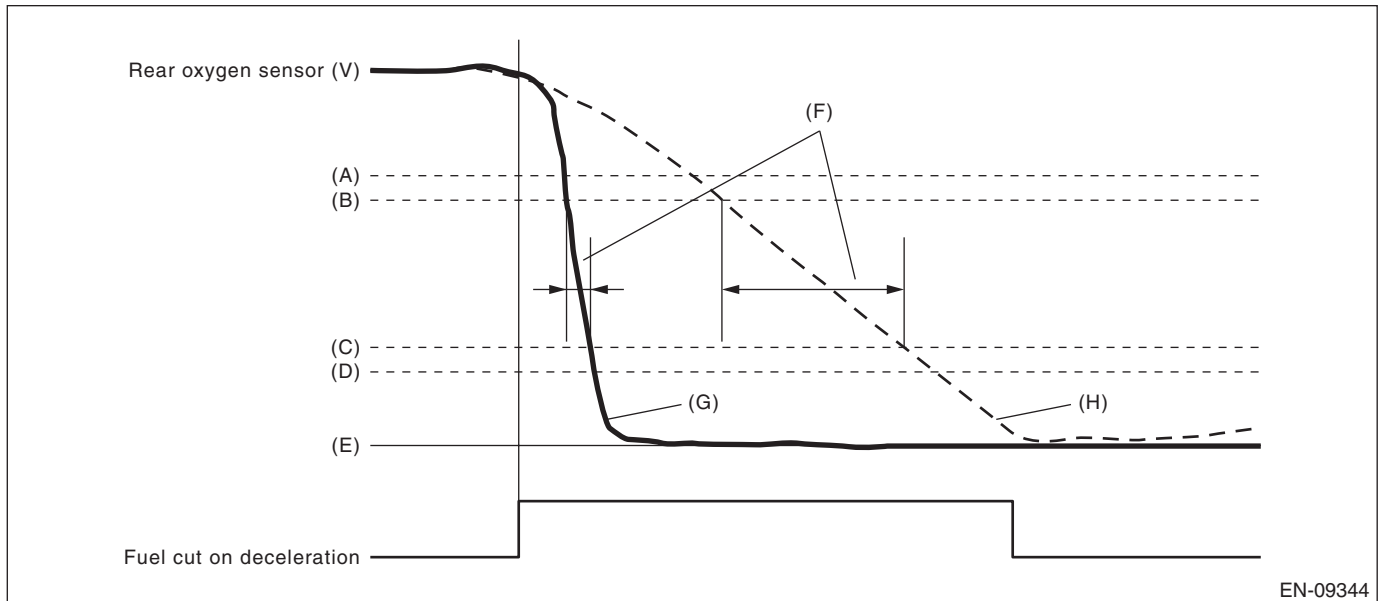

EN-09344

- |            |                 |                          |
|------------|-----------------|--------------------------|
| (A) 0.55 V | (B) 0.50 V      | (C) 0.20 V               |
| (D) 0.15 V | (E) 0 V         | (F) Diagnostic parameter |
| (G) Normal | (H) Malfunction |                          |

Judge as NG when the following conditions are established.

### Judgment Value

Malfunction Criteria	Threshold Value
Time needed for rear oxygen sensor voltage to change from 0.5 V to 0.2 V	> 837 ms

**Time Needed for Diagnosis:** 5 seconds

**Malfunction Indicator Light Illumination:** Illuminates when malfunction occurs in 2 continuous driving cycles.

# Diagnostic Trouble Code (DTC) Detecting Criteria

## GENERAL DESCRIPTION

### BI: DTC P013B O2 SENSOR SLOW RESPONSE - LEAN TO RICH (BANK 1 SENSOR 2)

#### 1. OUTLINE OF DIAGNOSIS

Detect the slow response of lean → rich for rear oxygen sensor output.

After the deceleration fuel cut has occurred, detect the trouble by calculating the time when the rear oxygen sensor output passes through the predetermined range of voltages.

Judge as NG when the response time is larger than the threshold value.

#### 2. COMPONENT DESCRIPTION

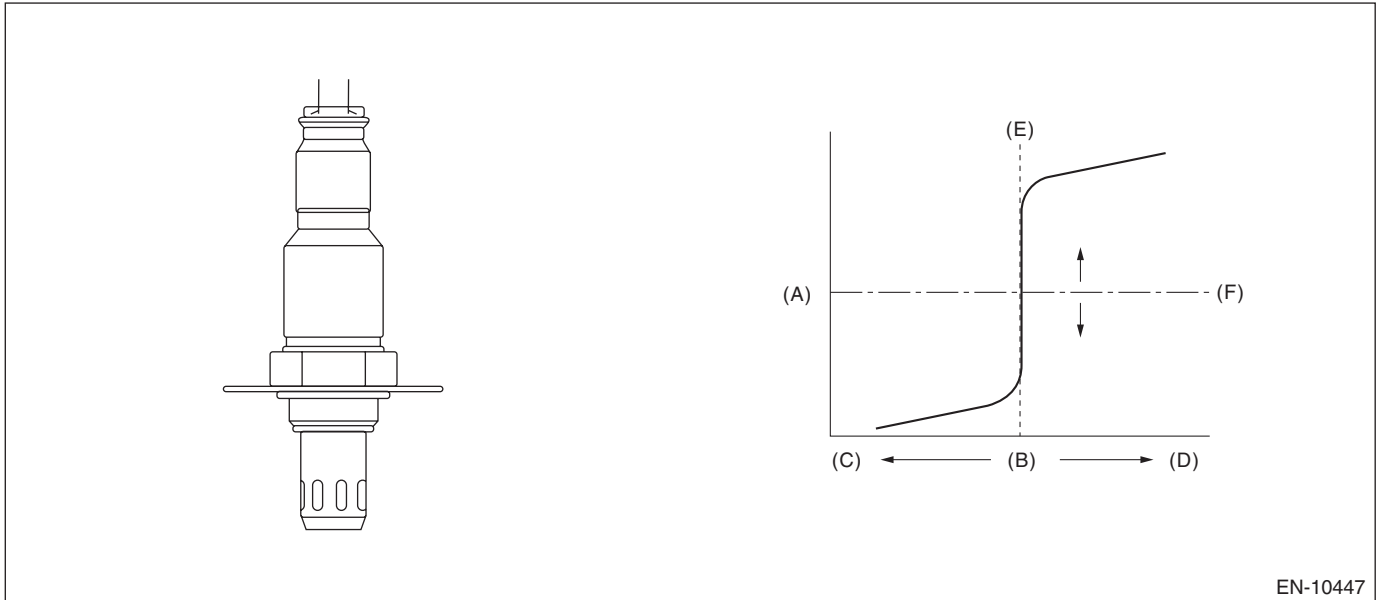

EN-10447

(A) Electromotive force

(B) Air fuel ratio

(C) Lean

(D) Rich

(E) Theoretical air fuel ratio

(F) Comparative voltage

#### 3. ENABLE CONDITIONS

Secondary Parameters	Enable Conditions
Battery voltage	≥ 10.9 V
Main feedback	In operation
Deceleration fuel cut of 5000 ms or more	Experienced

#### 4. GENERAL DRIVING CYCLE

Perform diagnosis only once after recovering from a deceleration fuel cut continued for more than predetermined time.

# Diagnostic Trouble Code (DTC) Detecting Criteria

GENERAL DESCRIPTION

## 5. DIAGNOSTIC METHOD

Detect the trouble by calculating the response time of the rear oxygen sensor after fuel cut.

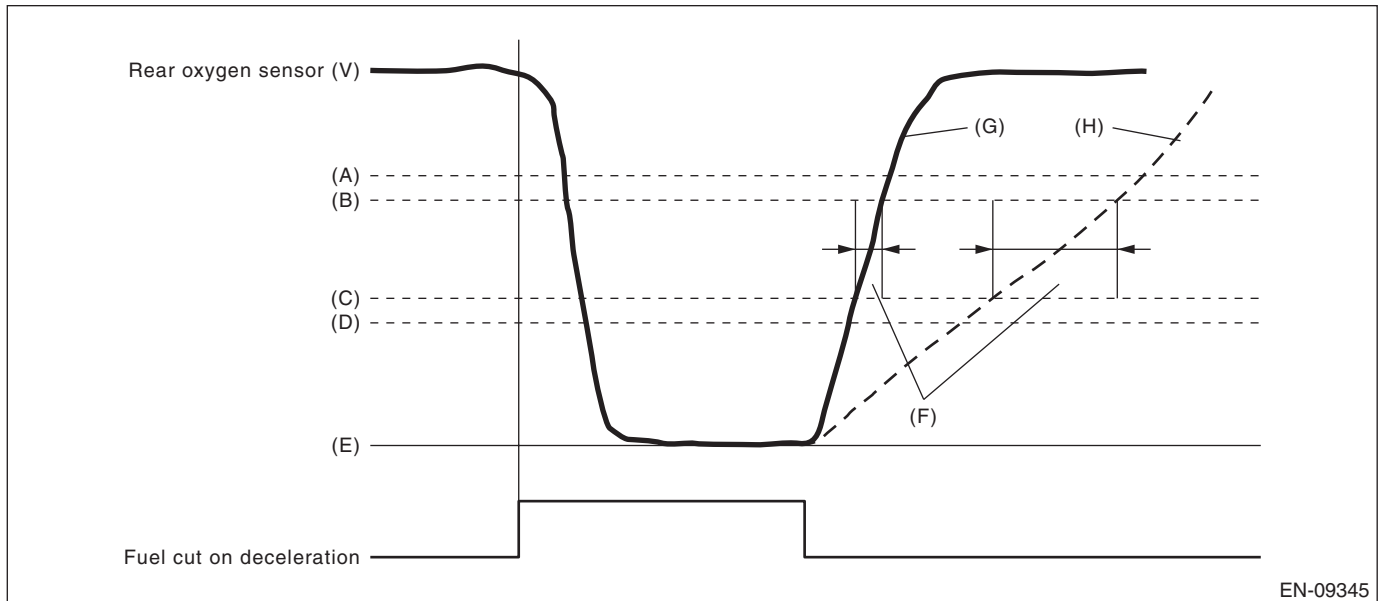

- |            |                 |                          |
|------------|-----------------|--------------------------|
| (A) 0.55 V | (B) 0.50 V      | (C) 0.30 V               |
| (D) 0.25 V | (E) 0 V         | (F) Diagnostic parameter |
| (G) Normal | (H) Malfunction |                          |

Judge as NG when the following conditions are established.

### Judgment Value

Malfunction Criteria	Threshold Value
Time when rear oxygen sensor voltage changed from 0.3 V to 0.5 V	> 4000 ms

**Time Needed for Diagnosis:** 4 seconds

**Malfunction Indicator Light Illumination:** Illuminates when malfunction occurs in 2 continuous driving cycles.

# Diagnostic Trouble Code (DTC) Detecting Criteria

## GENERAL DESCRIPTION

### BJ:DTC P013E O2 SENSOR DELAYED RESPONSE - RICH TO LEAN (BANK 1 SENSOR 2)

#### 1. OUTLINE OF DIAGNOSIS

Detect the delayed response of rear oxygen sensor output for rich → lean.

After the deceleration fuel cut has started, detect the trouble by calculating the time when the rear oxygen sensor output decreases to the predetermined voltages.

Judge as NG when the response time is larger than the threshold value.

#### 2. COMPONENT DESCRIPTION

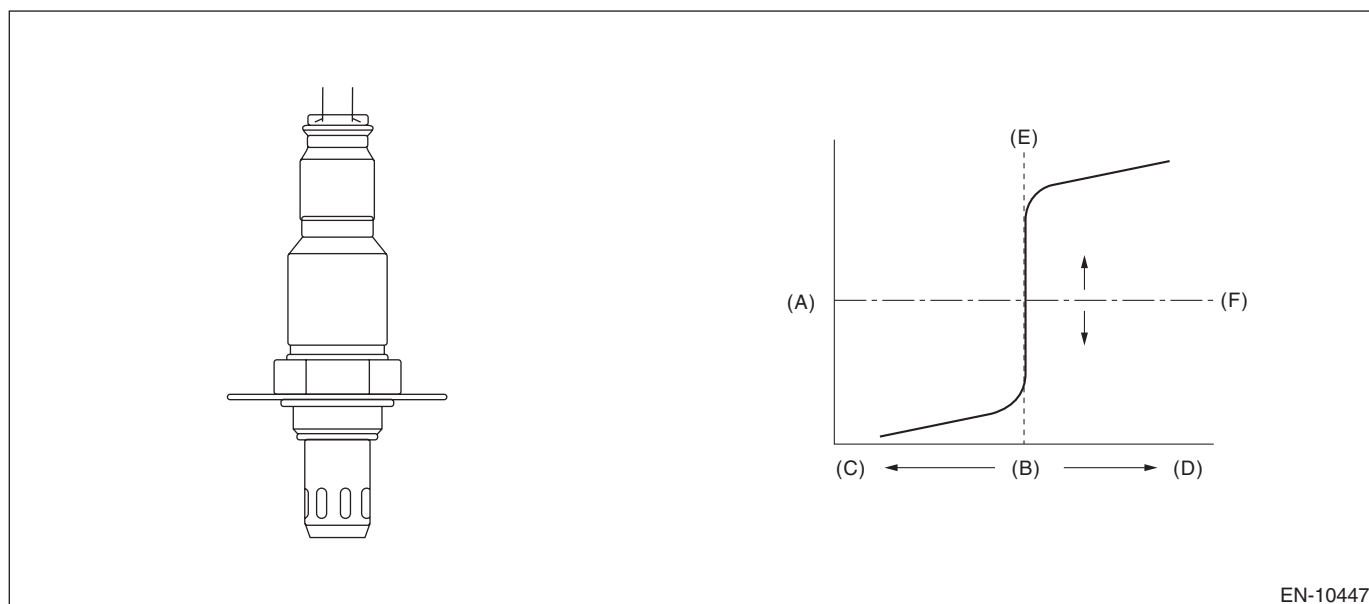

EN-10447

(A) Electromotive force

(B) Air fuel ratio

(C) Lean

(D) Rich

(E) Theoretical air fuel ratio

(F) Comparative voltage

#### 3. ENABLE CONDITIONS

Secondary Parameters	Enable Conditions
Battery voltage	$\geq 10.9 \text{ V}$
Rear oxygen sensor voltage when fuel cut starts	$\geq 0.55 \text{ V}$
Fuel cut	In operation
Estimated temperature of rear oxygen sensor element when fuel cut starts	$\geq 450^\circ\text{C}$ (842°F)
Fuel injection increase amount of exhaust system protection	= 0

#### 4. GENERAL DRIVING CYCLE

Perform diagnosis once during deceleration fuel cut from a constant and high speed driving, when rear oxygen sensor is warmed up sufficiently.

# Diagnostic Trouble Code (DTC) Detecting Criteria

GENERAL DESCRIPTION

## 5. DIAGNOSTIC METHOD

Detect the trouble by calculating the time from the beginning of the fuel cut to the beginning of the rear oxygen sensor voltage starting to drop.

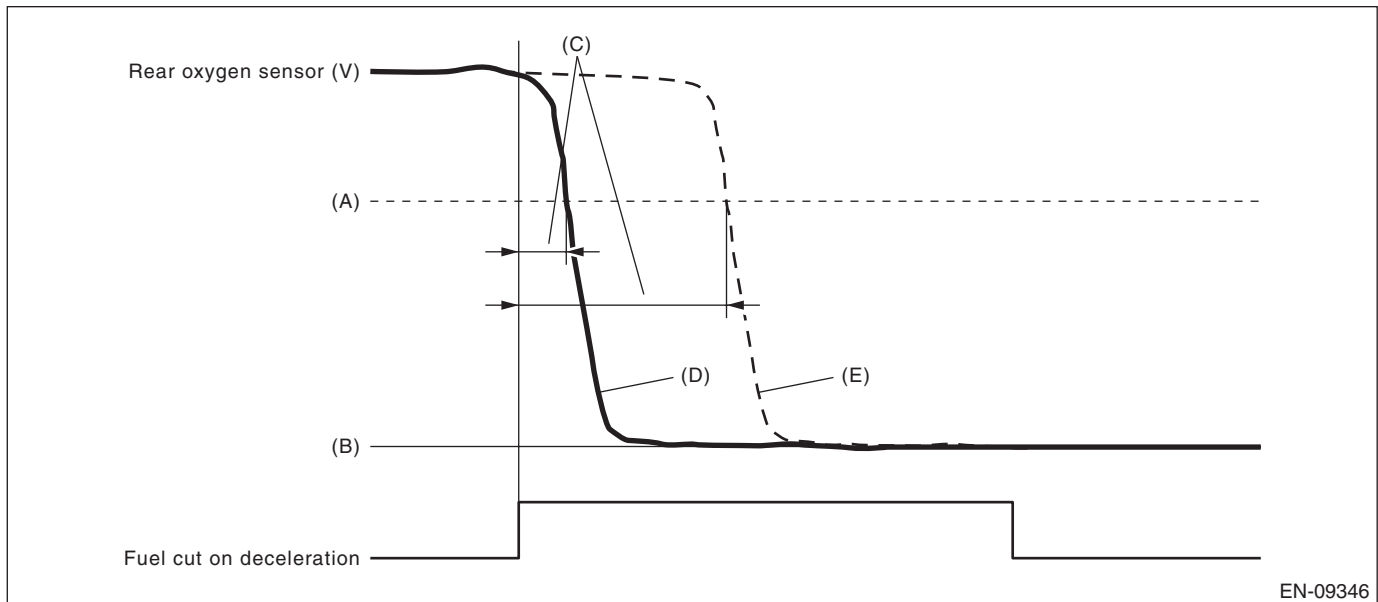

EN-09346

(A) 0.5 V

(B) 0 V

(C) Diagnostic parameter

(D) Normal

(E) Malfunction

Judge as NG when the following conditions are established.

### Judgment Value

Malfunction Criteria	Threshold Value
Time when rear oxygen sensor voltage changed to 0.5 V after the fuel cut started	> 4000 ms

**Time Needed for Diagnosis:** 5 seconds

**Malfunction Indicator Light Illumination:** Illuminates when malfunction occurs in 2 continuous driving cycles.

# Diagnostic Trouble Code (DTC) Detecting Criteria

## GENERAL DESCRIPTION

### BK:DTC P013F O2 SENSOR DELAYED RESPONSE - LEAN TO RICH (BANK 1 SENSOR 2)

#### 1. OUTLINE OF DIAGNOSIS

Detect the delayed response of rear oxygen sensor output for lean → rich.

After the deceleration fuel cut has completed, detect the trouble by calculating the time when the rear oxygen sensor output increases to the predetermined voltages.

Judge as NG when the response time is larger than the threshold value.

#### 2. COMPONENT DESCRIPTION

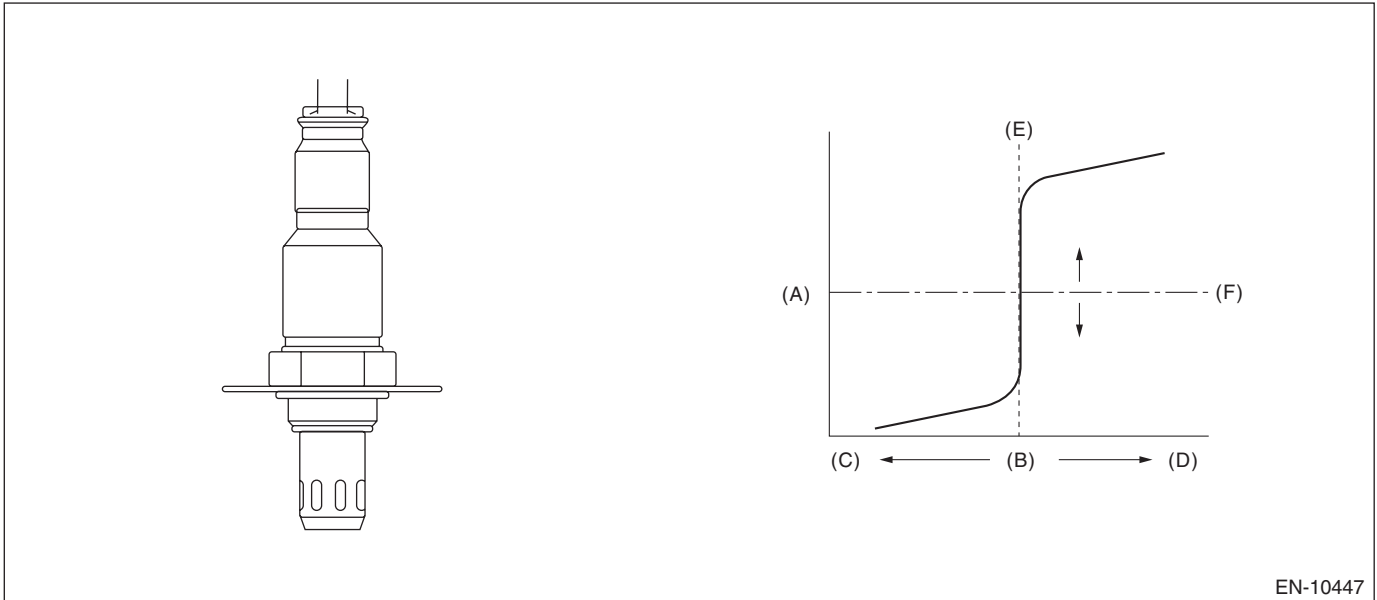

(A) Electromotive force

(B) Air fuel ratio

(C) Lean

(D) Rich

(E) Theoretical air fuel ratio

(F) Comparative voltage

#### 3. ENABLE CONDITIONS

Secondary Parameters	Enable Conditions
Battery voltage	≥ 10.9 V
Main feedback	In operation
Rear oxygen sensor voltage when fuel cut has completed	≤ 0.15 V
Deceleration fuel cut of 5000 ms or more	Experienced
Estimated element temperature of rear oxygen sensor when fuel cut has completed	≥ 450°C (842°F)

#### 4. GENERAL DRIVING CYCLE

Perform diagnosis only once when recovering from the deceleration fuel cut continued for more than predetermined time with the rear oxygen sensor warmed up sufficiently.





# Diagnostic Trouble Code (DTC) Detecting Criteria

## GENERAL DESCRIPTION

### BL:DTC P0141 O2 SENSOR HEATER CIRCUIT (BANK1 SENSOR2)

#### 1. OUTLINE OF DIAGNOSIS

Detect malfunction of the rear oxygen sensor heater.

Judge as NG if it is determined that the rear oxygen sensor impedance is large by observing the engine conditions.

#### 2. COMPONENT DESCRIPTION

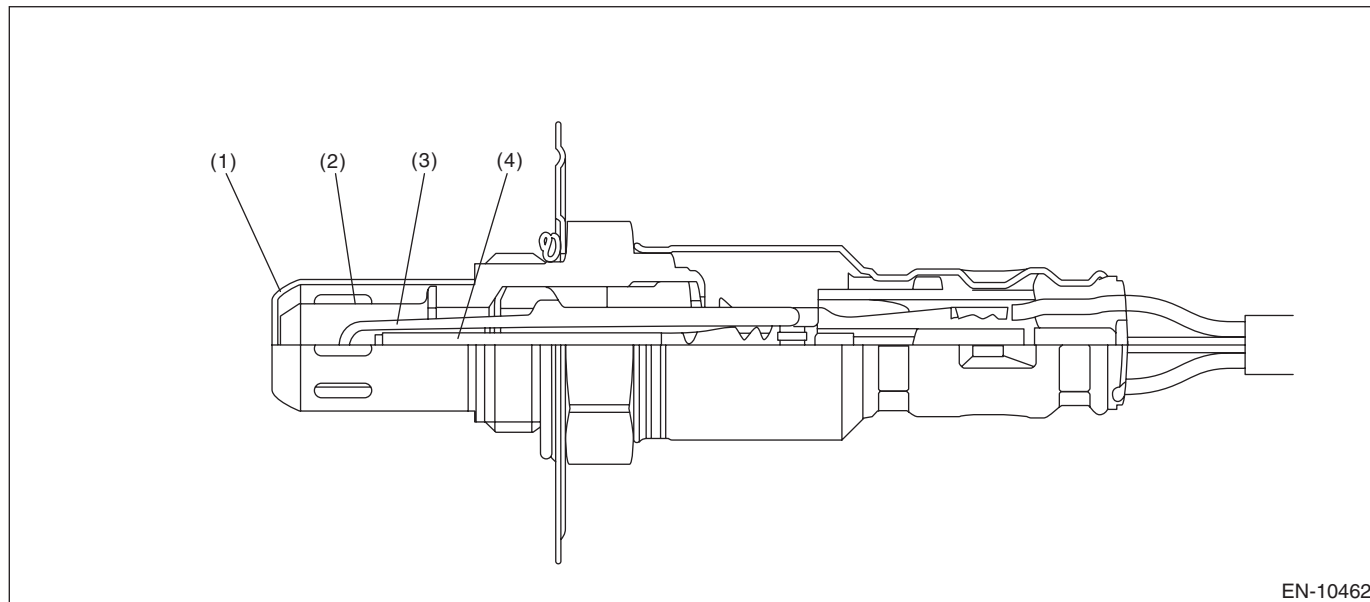

EN-10462

- (1) Element cover (outer)
- (2) Element cover (inner)
- (3) Sensor element
- (4) Ceramic heater

#### 3. ENABLE CONDITIONS

Secondary Parameters	Enable Conditions
Battery voltage	$\geq 10.9 \text{ V}$
Rear oxygen sensor heater control duty	$\geq 4\%$

#### 4. GENERAL DRIVING CYCLE

Always perform the diagnosis continuously.

#### 5. DIAGNOSTIC METHOD

If the duration of time while the following conditions are met is longer than the time indicated, judge as NG.

##### Judgment Value

Malfunction Criteria	Threshold Value
Rear oxygen sensor heater current	$< \text{Value from Map}$

##### Map

	10.9	12	13	14	15	16
Battery voltage (V)						
Threshold Value (mA)	330	357.5	385	412.5	440	467.5

**Time Needed for Diagnosis:** 10 seconds

**Malfunction Indicator Light Illumination:** Illuminates when malfunction occurs in 2 continuous driving cycles.

# Diagnostic Trouble Code (DTC) Detecting Criteria

GENERAL DESCRIPTION

## BM:DTC P014C O2 SENSOR SLOW RESPONSE - RICH TO LEAN (BANK 1 SENSOR 1)

### 1. OUTLINE OF DIAGNOSIS

Detect the slow response of front oxygen (A/F) sensor.

For diagnosis, detect the trouble by processing the  $\lambda$  waveform in normal driving without forcibly changing the target air fuel ratio.

### 2. COMPONENT DESCRIPTION

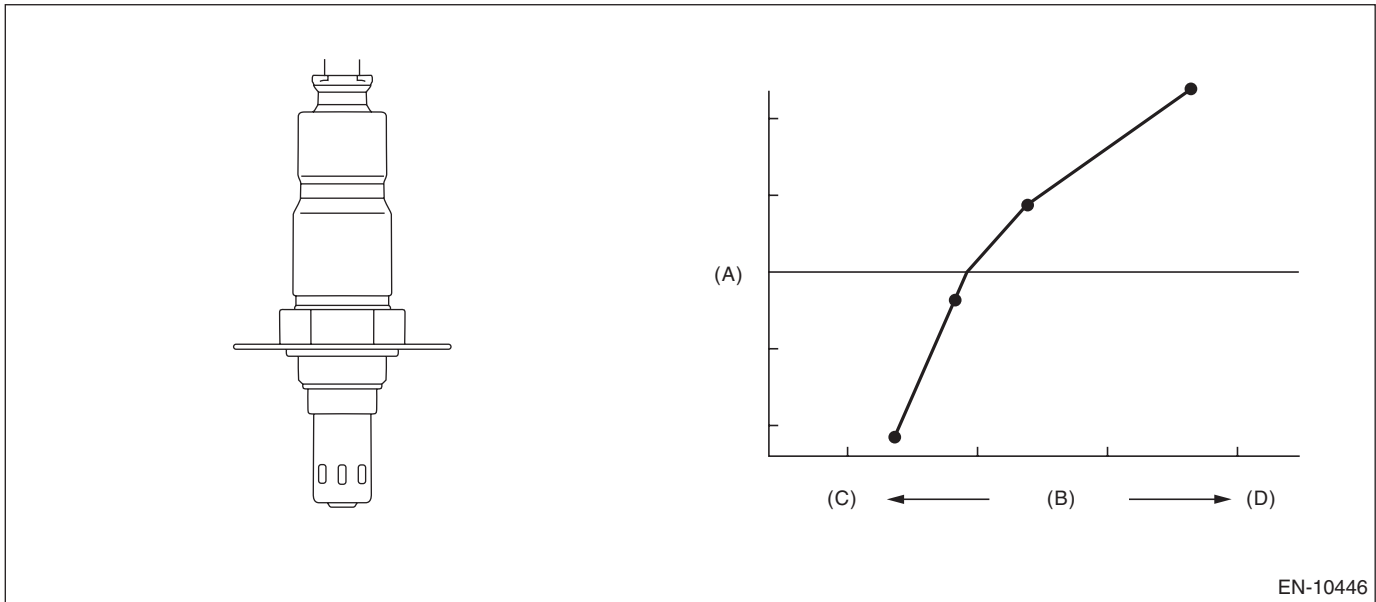

EN-10446

(A) Electromotive force

(B) Air fuel ratio

(C) Rich

(D) Lean

### 3. ENABLE CONDITIONS

Secondary Parameters	Enable Conditions
Battery voltage	$\geq 10.9$ V
Operation time of main feedback	$\geq 5$ s
Engine speed	$\geq 1000$ rpm
Amount of intake air	$\geq 10$ g/s (0.35 oz/s)

### 4. GENERAL DRIVING CYCLE

Perform diagnosis only once in a city driving including normal acceleration and deceleration.

# Diagnostic Trouble Code (DTC) Detecting Criteria

## GENERAL DESCRIPTION

### 5. DIAGNOSTIC METHOD 1

Detect the malfunction by checking “Cumulative value of time when  $\lambda$  changes from lean  $\rightarrow$  rich” in comparison to “Time during which diagnosis is in progress”.

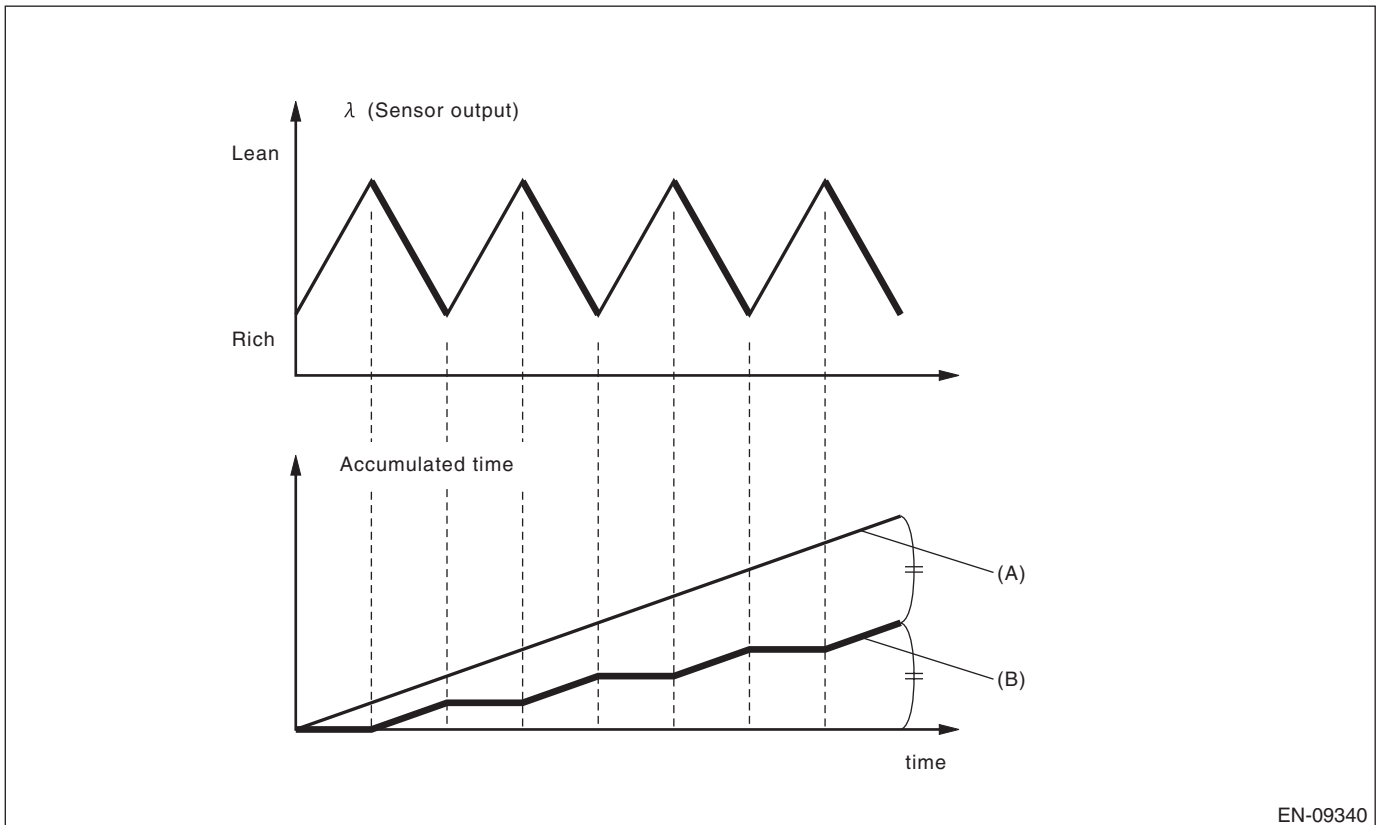

EN-09340

- (A) Time during which diagnosis is in progress      (B) Cumulative value of time when  $\lambda$  changes from lean  $\rightarrow$  rich

Judge as NG when the following conditions are established.

#### Judgment Value

Malfunction Criteria	Threshold Value	DTC
(Cumulative value of time when $\lambda$ changes from lean $\rightarrow$ rich) / (Time during which diagnosis is in progress)	< 0.38	P014C
	> 0.61	P014D

**Time Needed for Diagnosis:** 120 seconds

**Malfunction Indicator Light Illumination:** Illuminates when malfunction occurs in 2 continuous driving cycles.

# Diagnostic Trouble Code (DTC) Detecting Criteria

GENERAL DESCRIPTION

## 6. DIAGNOSTIC METHOD 2

Detect the malfunction by the cumulative value obtained from the amount of variation in  $\lambda$  change.

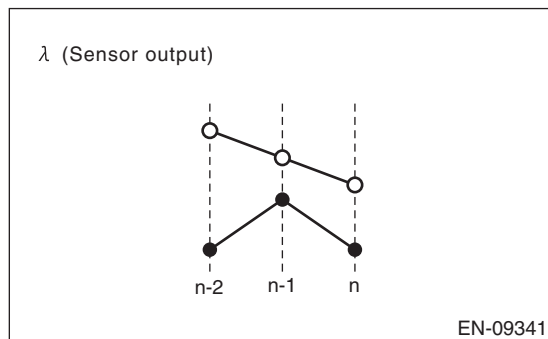

Judge as NG when the following conditions are established.

### Judgment Value

Malfunction Criteria	Threshold Value	DTC
Cumulative value obtained from the amount of variation in $\lambda$ change $\Sigma  (\lambda(n) - \lambda(n-1)) - (\lambda(n-1) - \lambda(n-2)) $	< Value from Map	P014C and P014D

### Map

Cumulative value obtained from the amount of variation in $\lambda$ $\Sigma  \lambda(n) - \lambda(n-1) $	0.00	3.00
Cumulative value obtained from the amount of variation in $\lambda$ change	0.00	2.50

**Time Needed for Diagnosis:** 120 seconds

**Malfunction Indicator Light Illumination:** Illuminates when malfunction occurs in 2 continuous driving cycles.

## BN:DTC P014D O2 SENSOR SLOW RESPONSE - LEAN TO RICH (BANK 1 SENSOR 1)

### 1. OUTLINE OF DIAGNOSIS

NOTE:

For the detection standard, refer to DTC P014C. <Ref. to GD(w/o STI)-77, DTC P014C O2 SENSOR SLOW RESPONSE - RICH TO LEAN (BANK 1 SENSOR 1), Diagnostic Trouble Code (DTC) Detecting Criteria.>

# Diagnostic Trouble Code (DTC) Detecting Criteria

## GENERAL DESCRIPTION

### BO:DTC P015A O2 SENSOR DELAYED RESPONSE - RICH TO LEAN (BANK 1 SENSOR 1)

#### 1. OUTLINE OF DIAGNOSIS

Detect the slow response of front oxygen (A/F) sensor.

For diagnosis, detect the trouble by processing the  $\lambda$  waveform in normal driving without forcibly changing the target air fuel ratio.

#### 2. COMPONENT DESCRIPTION

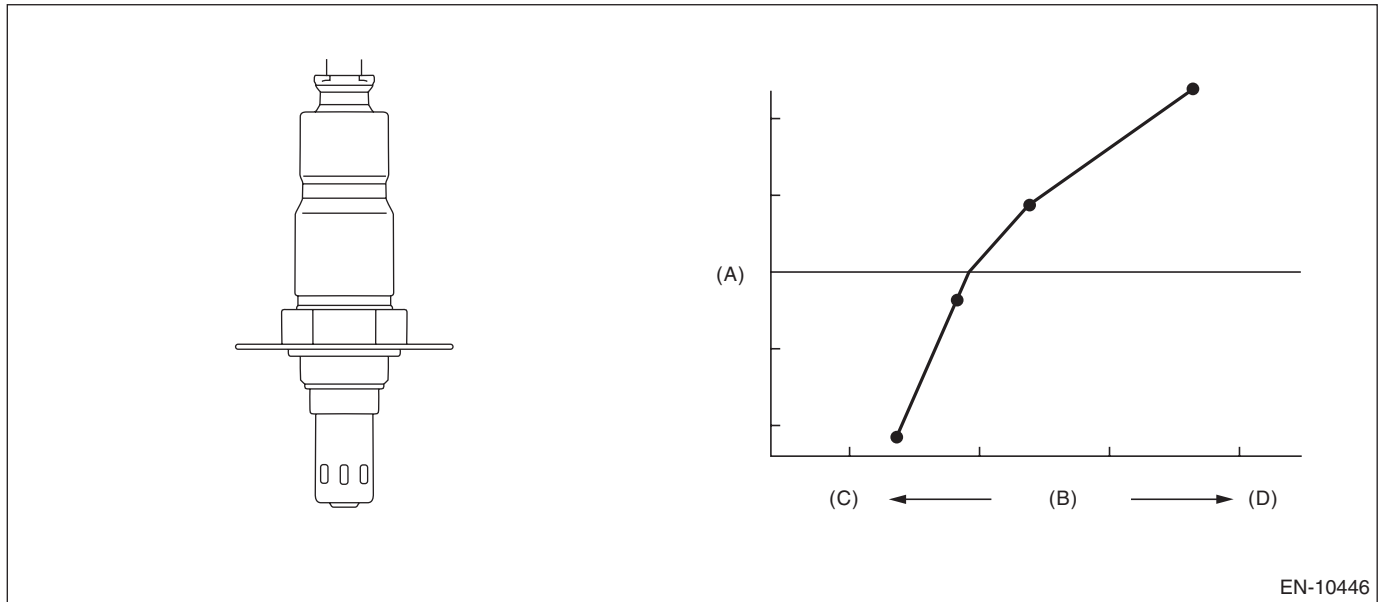

(A) Electromotive force  
(D) Lean

(B) Air fuel ratio

(C) Rich

#### 3. ENABLE CONDITIONS

##### Diagnostic method 1 and 2

Secondary Parameters	Enable Conditions
Battery voltage	$\geq 10.9$ V
Operation time of main feedback	$\geq 5$ s
Engine speed	$\geq 1000$ rpm
Amount of intake air	$\geq 10$ g/s (0.35 oz/s)

##### DIAGNOSIS METHOD 3 (MT MODEL ONLY)

Secondary Parameters	Enable Conditions
Battery voltage	$\geq 10.9$ V
Main feedback	In operation
Vehicle speed	$\geq 40$ km/h (24.9 MPH)
Engine speed	$\geq 1000$ rpm and $< 4000$ rpm
Amount of intake air	$\geq 7.5$ g/s (0.3 oz/s) and $< 40$ g/s (1.4 oz/s)
Catalyst depletion diagnosis	Not under diagnosis

#### 4. GENERAL DRIVING CYCLE

Perform diagnosis only once in a city driving including normal acceleration and deceleration.

# Diagnostic Trouble Code (DTC) Detecting Criteria

GENERAL DESCRIPTION

## 5. DIAGNOSTIC METHOD 1

Detect the malfunction depending on the average value of time necessary for  $\lambda$  to inverse the air fuel ratio from "Lean  $\rightarrow$  Rich  $\rightarrow$  Lean" to "Rich  $\rightarrow$  Lean  $\rightarrow$  Rich".

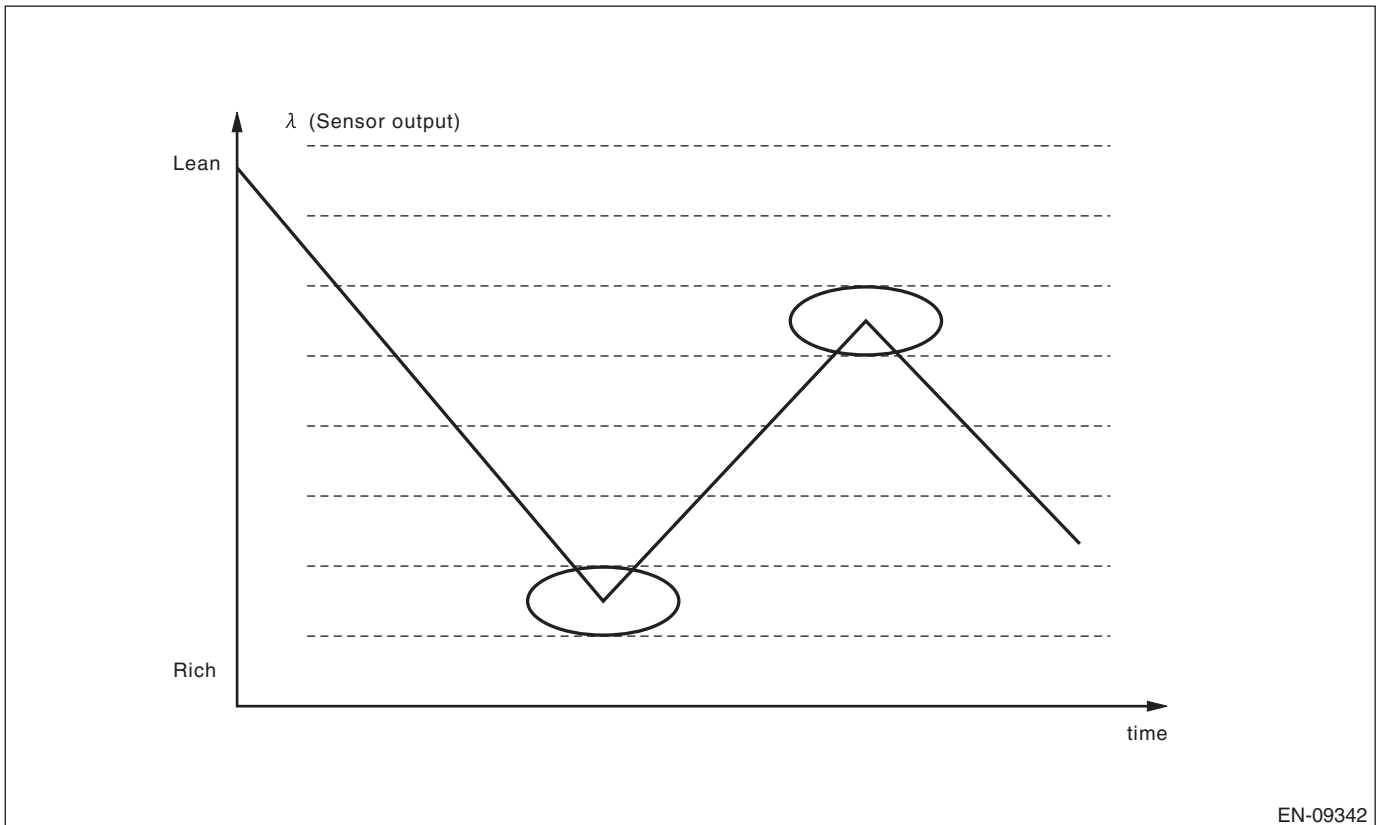

Judge as NG when the following conditions are established.

### Judgment Value

Malfunction Criteria	Threshold Value	DTC
Average value of time necessary for $\lambda$ to inverse the air fuel ratio to Lean $\rightarrow$ Rich $\rightarrow$ Lean	> 100 ms	P015A
Average value of time necessary for $\lambda$ to inverse the air fuel ratio to Rich $\rightarrow$ Lean $\rightarrow$ Rich	> 110 ms	P015B

**Time Needed for Diagnosis:** 100 times of inversion

**Malfunction Indicator Light Illumination:** Illuminates when malfunction occurs in 2 continuous driving cycles.

# Diagnostic Trouble Code (DTC) Detecting Criteria

## GENERAL DESCRIPTION

### 6. DIAGNOSTIC METHOD 2

Detect the malfunction by calculating the average amplitude of  $\lambda$ .

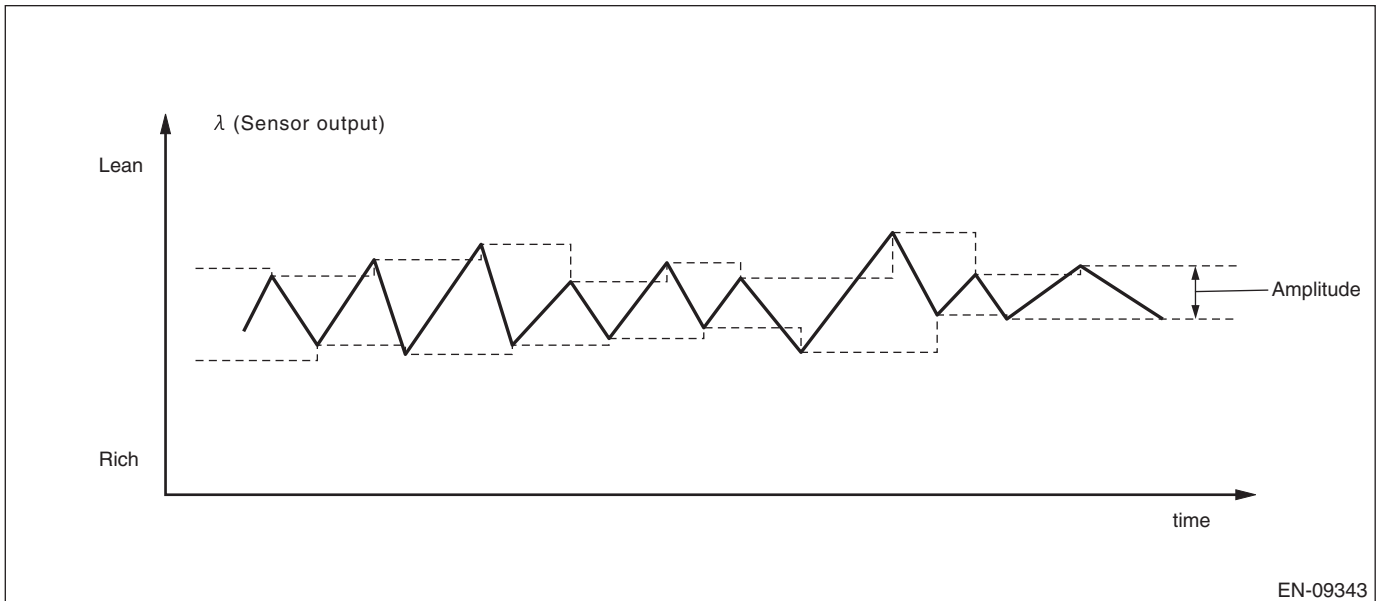

Judge as NG when the following conditions are established.

#### Judgment Value

Malfunction Criteria	Threshold Value	DTC
Average value for $\lambda$ amplitude	> 0.08	P015A and P015B

**Time Needed for Diagnosis:** 90 seconds

**Malfunction Indicator Light Illumination:** Illuminates when malfunction occurs in 2 continuous driving cycles.



# Diagnostic Trouble Code (DTC) Detecting Criteria

GENERAL DESCRIPTION

## 7. DIAGNOSIS METHOD 3 (MT MODEL ONLY)

Change STFT (A/F compensation value) by interruption, and measure the reaction time of  $\lambda$  value. When A/F sensor malfunctions, the reaction time takes longer than at normal condition. In this case, judge as abnormal.

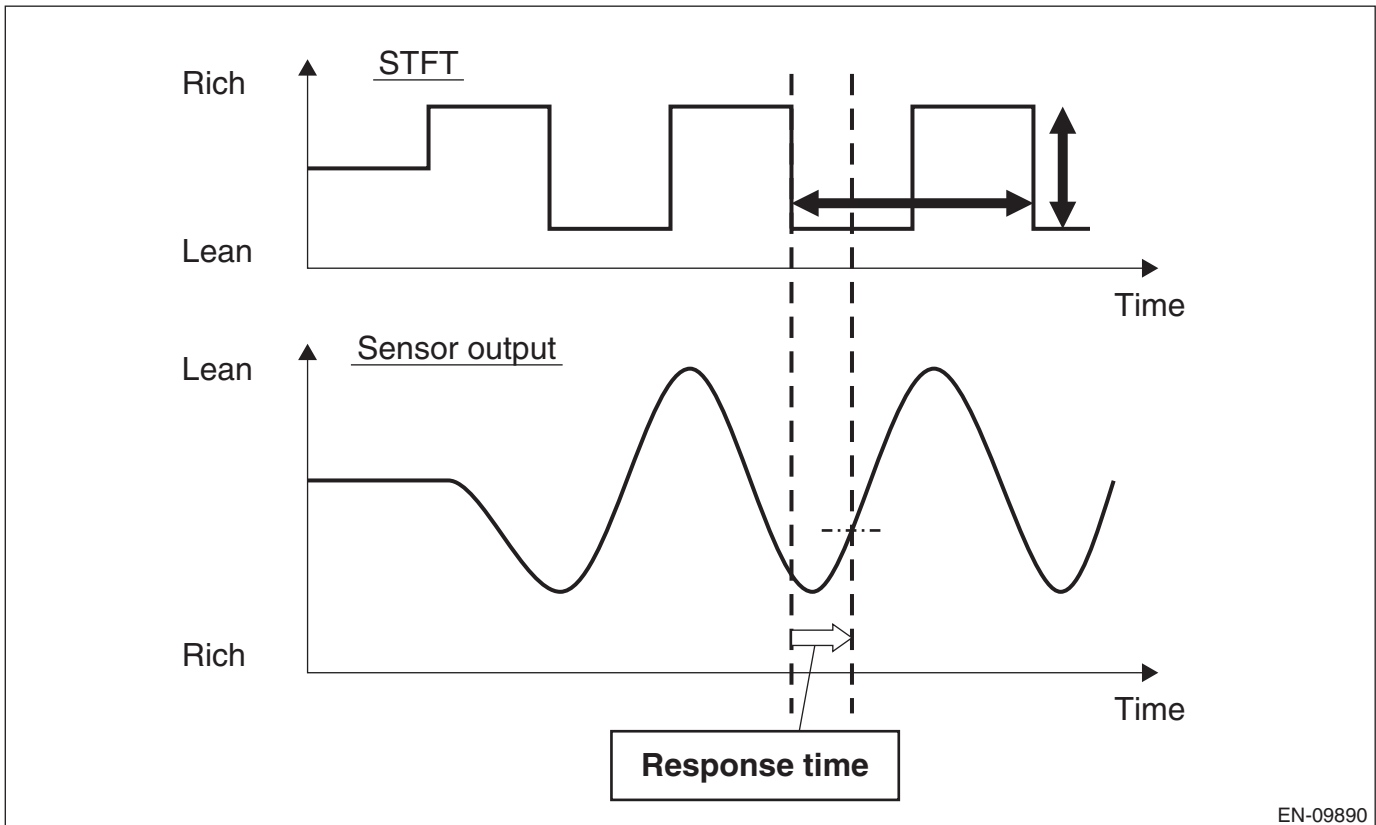

# Diagnostic Trouble Code (DTC) Detecting Criteria

## GENERAL DESCRIPTION

Measure reaction time (t1, t2, t3) and reaction time (t4, t5, t6). Use the average value of the reaction time to obtain the diagnostic value.

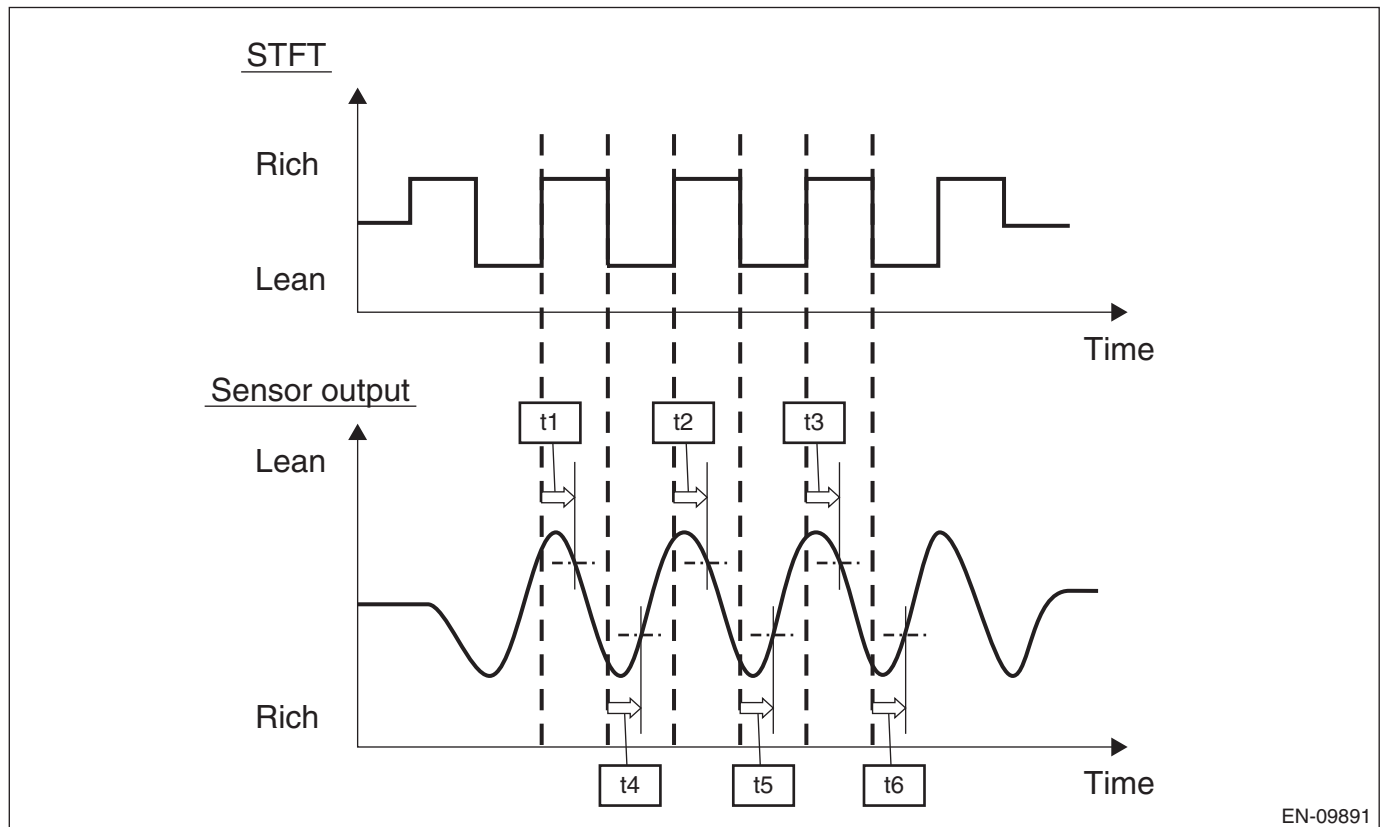

Judge as NG when the following conditions are established.

### Judgment Value

Malfunction Criteria	Threshold Value	DTC
$(t1 + t2 + t3)/3$ and $(t4 + t5 + t6)/3$	> 0.8 s  > 0.8 s	P015A and P015B

**Time Needed for Diagnosis:** 4.5 seconds

**Malfunction Indicator Light Illumination:** Illuminates when malfunction occurs in 2 continuous driving cycles.

## BP:DTC P015B O2 SENSOR DELAYED RESPONSE - LEAN TO RICH (BANK 1 SENSOR 1)

### 1. OUTLINE OF DIAGNOSIS

NOTE:

For the detection standard, refer to DTC P015A. <Ref. to GD(w/o STI)-80, DTC P015A O2 SENSOR DELAYED RESPONSE - RICH TO LEAN (BANK 1 SENSOR 1), Diagnostic Trouble Code (DTC) Detecting Criteria.>

# Diagnostic Trouble Code (DTC) Detecting Criteria

GENERAL DESCRIPTION

## BQ:DTC P0171 SYSTEM TOO LEAN (BANK 1)

### 1. OUTLINE OF DIAGNOSIS

Detect fuel system malfunction by the amount of main feedback control.

Fuel system is diagnosed by comparing the target air fuel ratio calculated by ECM with the actual air fuel ratio measured by sensor.

### 2. ENABLE CONDITIONS

Secondary Parameters	Enable Conditions
Main feedback	In operation

### 3. GENERAL DRIVING CYCLE

Perform the diagnosis continuously during main feedback.

### 4. DIAGNOSTIC METHOD

Compare the diagnostic value with the threshold value, and if a condition meeting the criteria continues for  $10\text{ s} \times 3$  times or more, judge that there is a fault in the fuel system.

#### Judgment Value

Malfunction Criteria	Threshold Value
$\text{faf} \times (1 + \text{flaf})$ faf = Main feedback compensation coefficient flaf = main feedback learning compensation coefficient	> 1.35

**Time Needed for Diagnosis:**  $10\text{ s} \times 3$  times

**Malfunction Indicator Light Illumination:** Illuminates when malfunction occurs in 2 continuous driving cycles.

# Diagnostic Trouble Code (DTC) Detecting Criteria

## GENERAL DESCRIPTION

### BR:DTC P0172 SYSTEM TOO RICH (BANK 1)

#### 1. OUTLINE OF DIAGNOSIS

Detect fuel system malfunction by the amount of main feedback control.

Fuel system is diagnosed by comparing the target air fuel ratio calculated by ECM with the actual air fuel ratio measured by sensor.

#### 2. ENABLE CONDITIONS

Secondary Parameters	Enable Conditions
Main feedback	In operation

#### 3. GENERAL DRIVING CYCLE

Perform the diagnosis continuously after idling.

#### 4. DIAGNOSTIC METHOD

Compare the diagnostic value with the threshold value, and if a condition meeting the criteria continues for 10 s × 3 times or more, judge that there is a fault in the fuel system.

#### Judgment Value

Malfunction Criteria	Threshold Value
$faf \times (1 + flaf)$ faf = Main feedback compensation coefficient flaf = main feedback learning compensation coefficient	< Value from Map

#### Map

Warm-up increase compensation coefficient	0.00	0.10	0.20	0.30	0.33	0.50	0.60
Threshold Value	0.650	0.550	0.458	0.383	0.360	0.360	0.360

**Time Needed for Diagnosis:** 10 s × 3 times

**Malfunction Indicator Light Illumination:** Illuminates when malfunction occurs in 2 continuous driving cycles.

# Diagnostic Trouble Code (DTC) Detecting Criteria

GENERAL DESCRIPTION

## BS:DTC P0191 FUEL RAIL PRESSURE SENSOR "A" CIRCUIT RANGE/PERFORMANCE

### 1. OUTLINE OF DIAGNOSIS

Detect the signal stuck of the fuel pressure sensor.

Judge as NG when the voltage change amount per unit time of the fuel pressure sensor does not exceed the threshold value.

### 2. ENABLE CONDITIONS

Secondary Parameters	Enable Conditions
Battery voltage	$\geq 10.9$ V
Engine speed	$\geq 475$ rpm
Fuel cut	Not performed

### 3. GENERAL DRIVING CYCLE

Perform the diagnosis continuously after starting the engine.

### 4. DIAGNOSTIC METHOD

If the duration of time while the following conditions are met is longer than the time indicated, judge as NG.

#### Judgment Value

Malfunction Criteria	Threshold Value
Change amount per unit time of fuel pressure sensor voltage	$\leq 3.8$ V/s

**Time Needed for Diagnosis:** 10 seconds

**Malfunction Indicator Light Illumination:** Illuminates when malfunction occurs in 2 continuous driving cycles.

# Diagnostic Trouble Code (DTC) Detecting Criteria

## GENERAL DESCRIPTION

### BT:DTC P0192 FUEL RAIL PRESSURE SENSOR CIRCUIT LOW

#### 1. OUTLINE OF DIAGNOSIS

Detect the open or short circuit of the fuel pressure sensor.  
Judge as NG if out of specification.

#### 2. COMPONENT DESCRIPTION

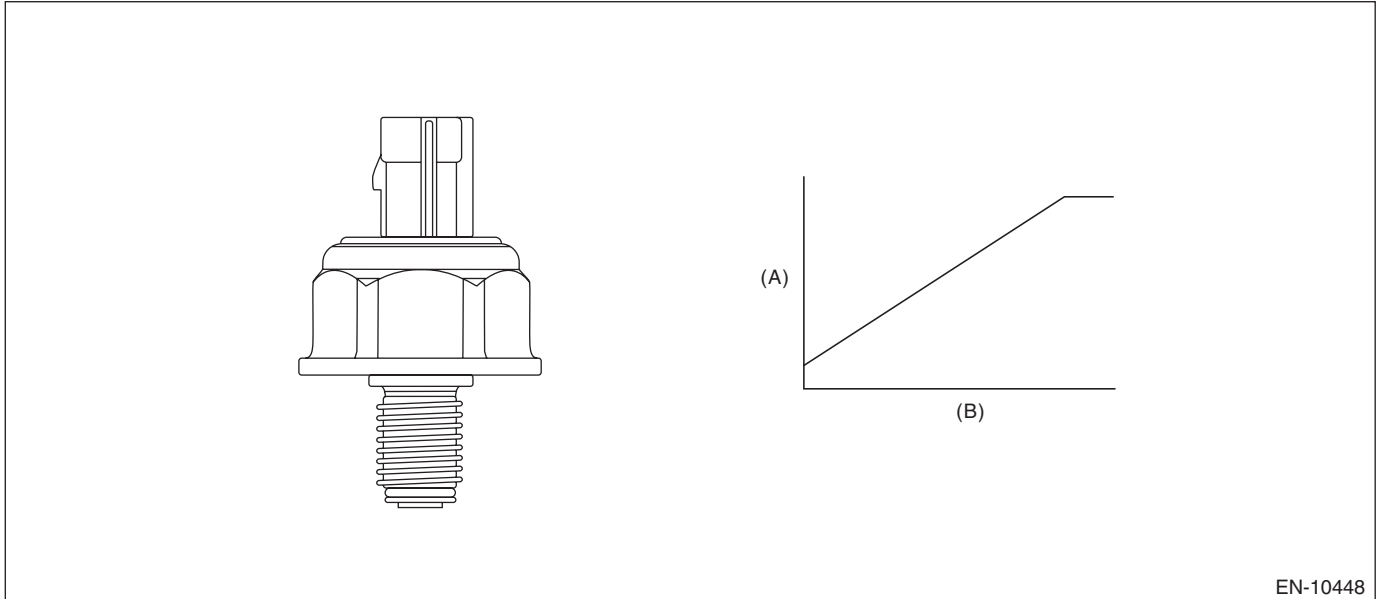

(A) Output voltage

(B) Absolute pressure

#### 3. ENABLE CONDITIONS

Secondary Parameters	Enable Conditions
None	

#### 4. GENERAL DRIVING CYCLE

Always perform the diagnosis continuously.

#### 5. DIAGNOSTIC METHOD

If the duration of time while the following conditions are met is longer than the time indicated, judge as NG.

##### Judgment Value

Malfunction Criteria	Threshold Value
Output voltage	< 0.23 V

**Time Needed for Diagnosis:** 2500 ms

**Malfunction Indicator Light Illumination:** Illuminates as soon as a malfunction occurs.

# Diagnostic Trouble Code (DTC) Detecting Criteria

GENERAL DESCRIPTION

## BU:DTC P0193 FUEL RAIL PRESSURE SENSOR CIRCUIT HIGH

### 1. OUTLINE OF DIAGNOSIS

Detect the open or short circuit of the fuel pressure sensor.  
Judge as NG if out of specification.

### 2. COMPONENT DESCRIPTION

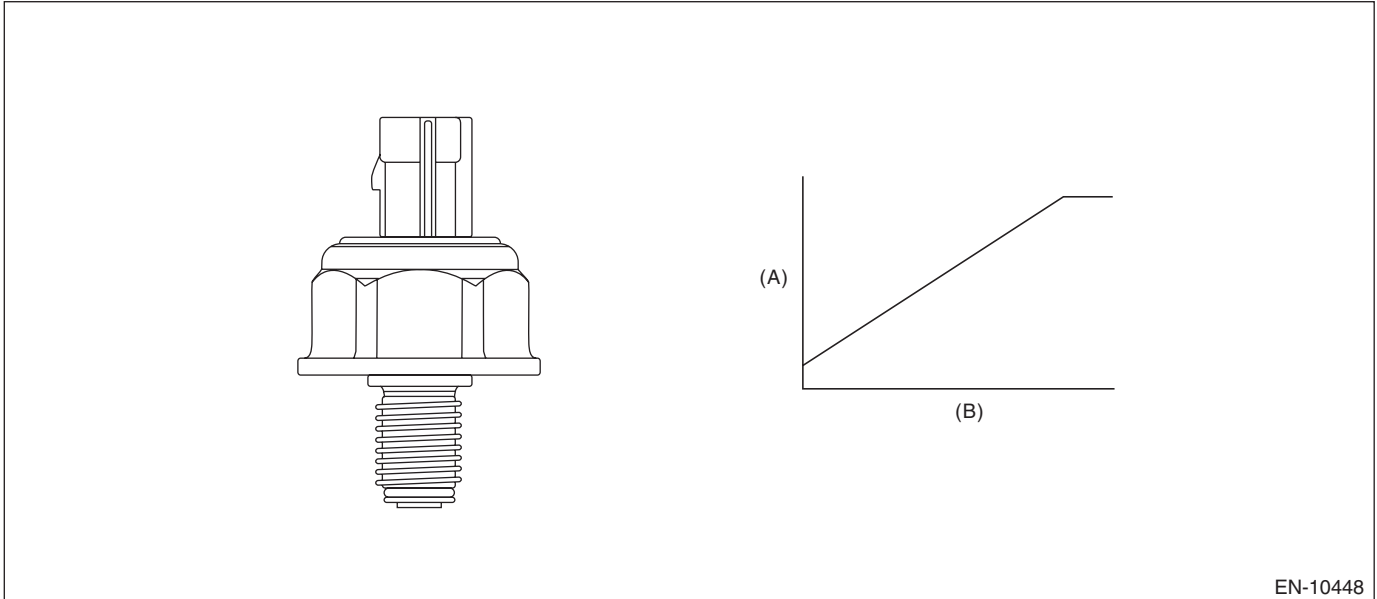

(A) Output voltage

(B) Absolute pressure

### 3. ENABLE CONDITIONS

Secondary Parameters	Enable Conditions
None	

### 4. GENERAL DRIVING CYCLE

Always perform the diagnosis continuously.

### 5. DIAGNOSTIC METHOD

If the duration of time while the following conditions are met is longer than the time indicated, judge as NG.

#### Judgment Value

Malfunction Criteria	Threshold Value
Output voltage	> 3.25 V

**Time Needed for Diagnosis:** 2500 ms

**Malfunction Indicator Light Illumination:** Illuminates as soon as a malfunction occurs.

# Diagnostic Trouble Code (DTC) Detecting Criteria

## GENERAL DESCRIPTION

### BV:DTC P0196 ENGINE OIL TEMPERATURE SENSOR CIRCUIT RANGE/PERFORMANCE

#### 1. OUTLINE OF DIAGNOSIS

Detect the malfunction of the engine oil temperature sensor output properties. Using the following two diagnoses, judge as NG when either is NG.

- **Diagnosis 1 (correlation diagnosis):** After the engine starts after the specified period of soaking time has elapsed, diagnose by correlation between engine oil temperature sensor value, engine coolant temperature sensor value and intake air temperature sensor value. Judge as NG when the differences are both above the specified value by comparing between engine oil temperature and engine coolant temperature, engine oil temperature and intake air temperature.
- **Diagnosis 2 (function diagnosis):** Judge as NG when engine oil temperature does not rise to the specified value regardless of an engine running condition that clears certain conditions.

#### 2. COMPONENT DESCRIPTION

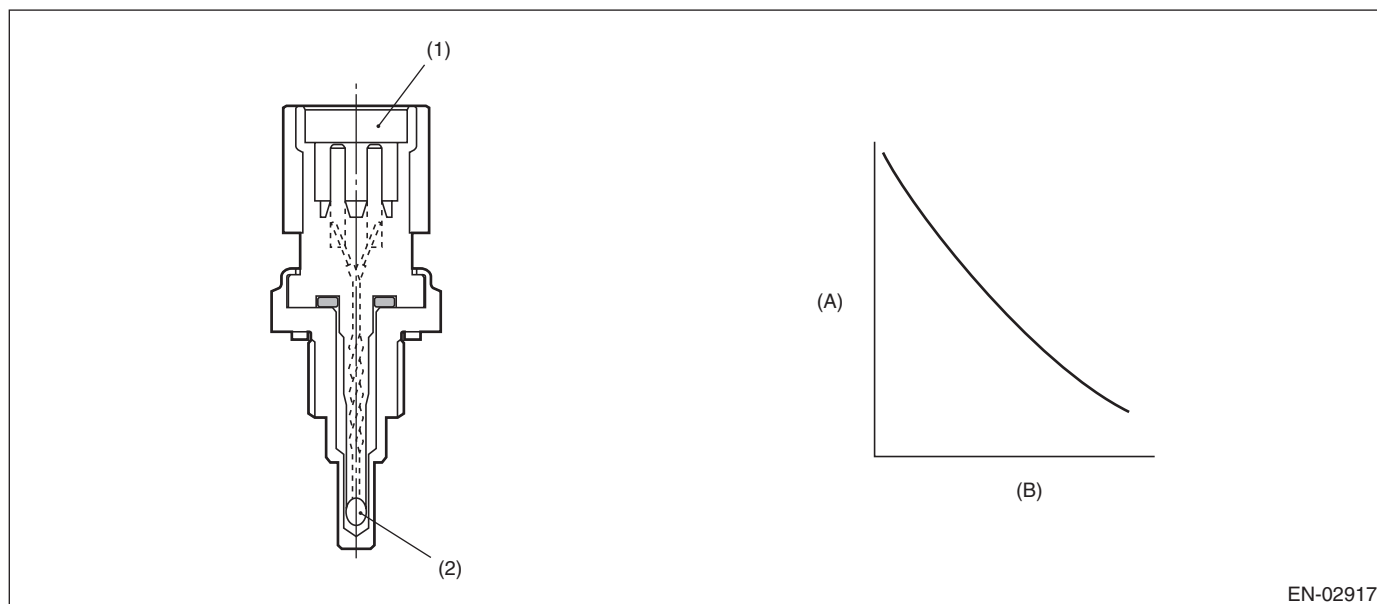

EN-02917

(A) Resistance value (k $\Omega$ )

(B) Temperature °C (°F)

(1) Connector

(2) Thermistor element

#### 3. ENABLE CONDITIONS

##### Diagnosis 1

Secondary Parameters	Enable Conditions
Soaking time	$\geq 21600$ s
Block heater judgment	Completed
Block heater operation	Not in operation

##### Diagnosis 2

Secondary Parameters	Enable Conditions
Engine oil temperature at engine starting	$< 50^{\circ}\text{C}$ ( $122^{\circ}\text{F}$ )
Engine speed	$> 475$ rpm
Idling ratio	$\leq 50\%$

#### 4. GENERAL DRIVING CYCLE

- **Diagnosis 1:** Perform the diagnosis only once after the engine starts after a certain period of soaking time.
- **Diagnosis 2:** Perform the diagnosis only once after starting the engine from cold condition.



# Diagnostic Trouble Code (DTC) Detecting Criteria

GENERAL DESCRIPTION

## 5. DIAGNOSTIC METHOD

Judge as NG when Diagnosis 1 or Diagnosis 2 becomes NG.

If the duration of time while the following conditions are met is longer than the time indicated, judge as NG.

### Diagnosis 1

#### Judgment Value

Malfunction Criteria	Threshold Value
Engine oil temperature at engine start – Engine coolant temperature at engine start	> 10°C (18°F)
Engine oil temperature at engine start – Intake air temperature 30 sec. after engine start	> Value of Map 1

### Map 1

Ambient air temperature °C (°F)	-30 (-22)	30 (86)	45 (113)	60 (140)
Engine oil temperature at engine start – Intake air temperature 30 sec. after engine start  °C (°F)	10 (18)	10 (18)	22 (39.6)	22 (39.6)

**Time Needed for Diagnosis:** Less than 1 second

### Diagnosis 2

#### Judgment Value

Malfunction Criteria	Threshold Value
Engine oil temperature	< 50°C (122°F)
Elapsed time after starting the engine	≥ Value from Map 2

### Map 2

Intake air temperature at engine start °C (°F)	-30 (-22)	-20 (-4)	-10 (14)	0 (32)	10 (50)	20 (68)	30 (86)	40 (104)
Elapsed time after starting the engine s	2,800	2,100	1,400	900	650	500	400	400

**Time Needed for Diagnosis:** Value of Map 2

**Malfunction Indicator Light Illumination:** Illuminates when malfunction occurs in 2 continuous driving cycles.

# Diagnostic Trouble Code (DTC) Detecting Criteria

## GENERAL DESCRIPTION

### BW:DTC P0197 ENGINE OIL TEMPERATURE SENSOR LOW

#### 1. OUTLINE OF DIAGNOSIS

Detect the open or short circuit of the oil temperature sensor.  
Judge as NG when outside of the judgment value.

#### 2. COMPONENT DESCRIPTION

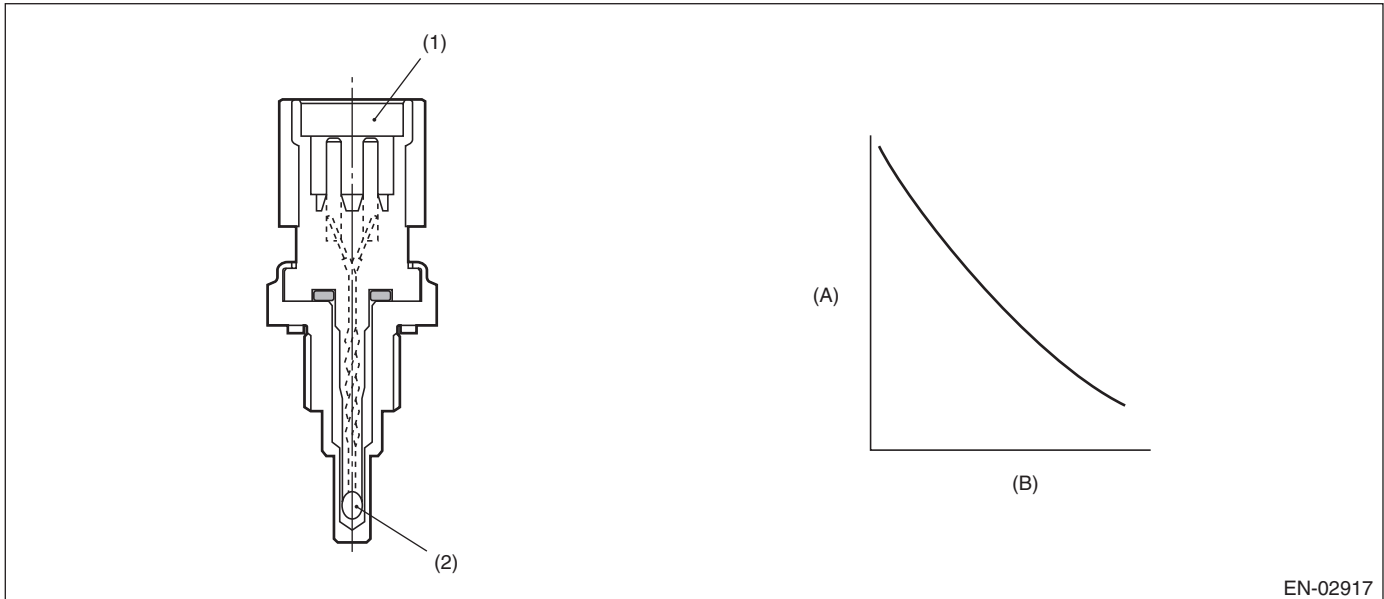

EN-02917

(A) Resistance value (k $\Omega$ )

(B) Temperature °C (°F)

(1) Connector

(2) Thermistor element

#### 3. ENABLE CONDITIONS

Secondary Parameters	Enable Conditions
None	

#### 4. GENERAL DRIVING CYCLE

Always perform the diagnosis continuously.

#### 5. DIAGNOSTIC METHOD

If the duration of time while the following conditions are met is longer than the time indicated, judge as NG.

##### Judgment Value

Malfunction Criteria	Threshold Value
Output voltage	< 0.18 V

**Time Needed for Diagnosis:** 0.5 seconds

**Malfunction Indicator Light Illumination:** Illuminates as soon as a malfunction occurs.

# Diagnostic Trouble Code (DTC) Detecting Criteria

GENERAL DESCRIPTION

## BX:DTC P0198 ENGINE OIL TEMPERATURE SENSOR HIGH

### 1. OUTLINE OF DIAGNOSIS

Detect the open or short circuit of the oil temperature sensor.  
Judge as NG when outside of the judgment value.

### 2. COMPONENT DESCRIPTION

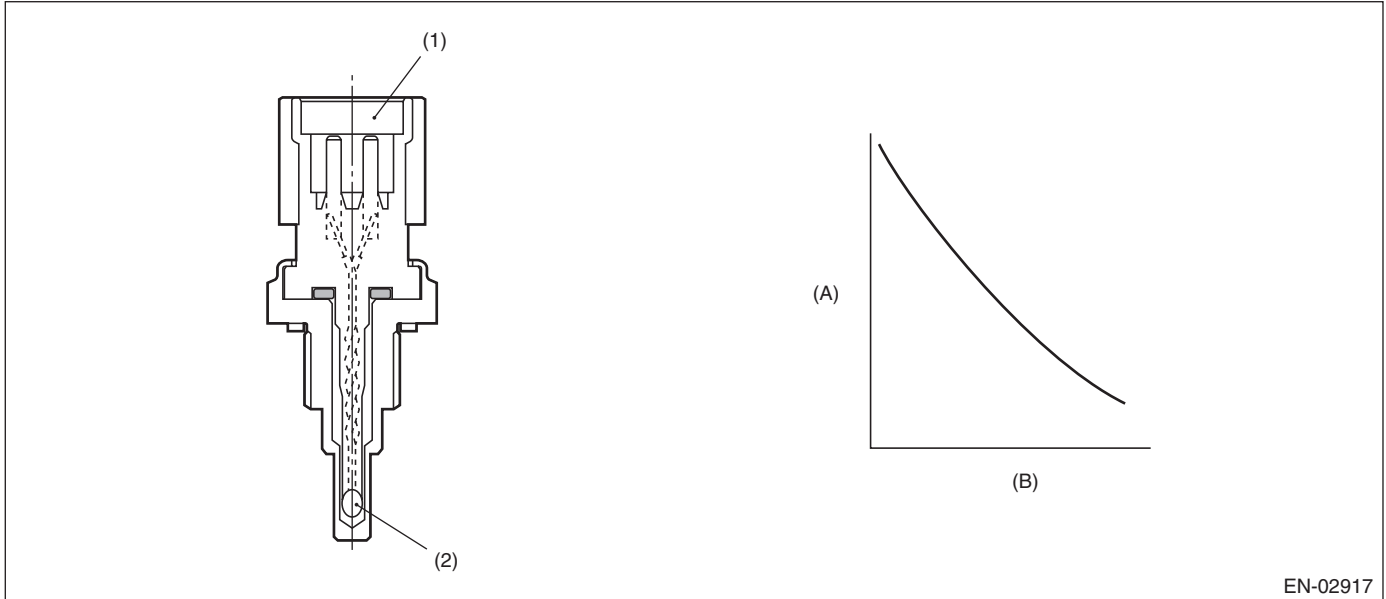

EN-02917

(A) Resistance value (k $\Omega$ )

(B) Temperature °C (°F)

(1) Connector

(2) Thermistor element

### 3. ENABLE CONDITIONS

Secondary Parameters	Enable Conditions
None	

### 4. GENERAL DRIVING CYCLE

Always perform the diagnosis continuously.

### 5. DIAGNOSTIC METHOD

If the duration of time while the following conditions are met is longer than the time indicated, judge as NG.

#### Judgment Value

Malfunction Criteria	Threshold Value
Output voltage	> 4.71 V

**Time Needed for Diagnosis:** 0.5 seconds

**Malfunction Indicator Light Illumination:** Illuminates as soon as a malfunction occurs.

# Diagnostic Trouble Code (DTC) Detecting Criteria

## GENERAL DESCRIPTION

### BY:DTC P0222 THROTTLE/PEDAL POSITION SENSOR/SWITCH “B” CIRCUIT LOW

#### 1. OUTLINE OF DIAGNOSIS

Detect the open or short circuit of throttle position sensor 2.  
Judge as NG if out of specification.

#### 2. COMPONENT DESCRIPTION

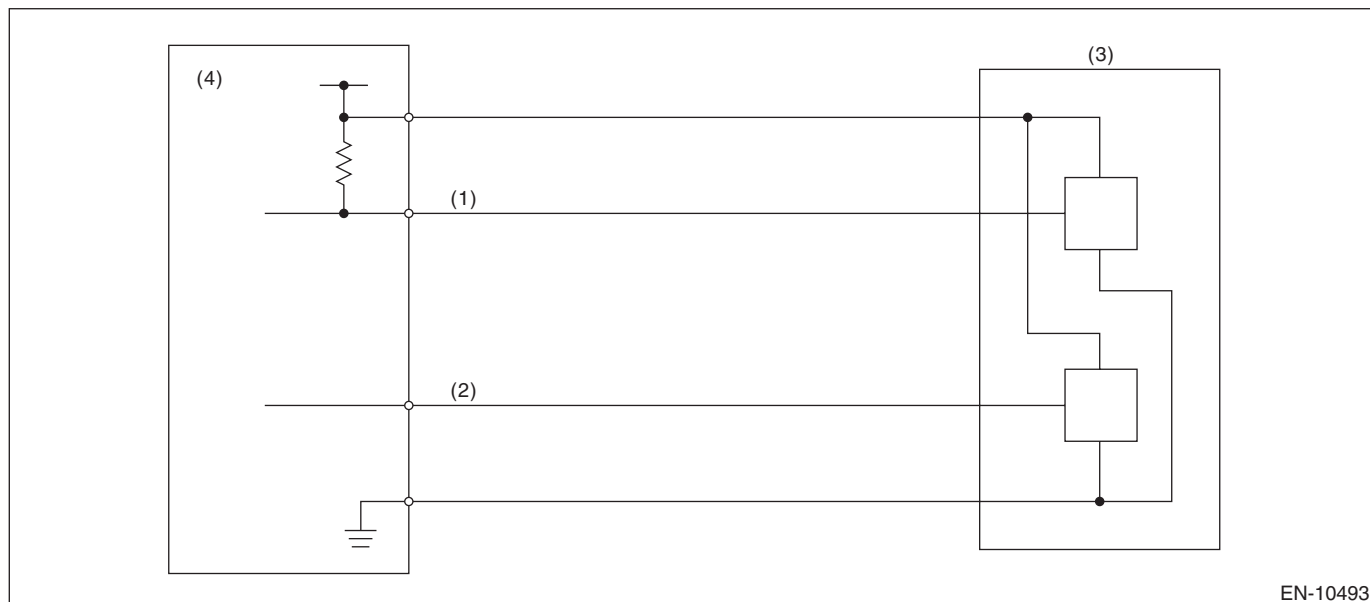

EN-10493

- (1) Throttle position sensor 1 signal      (3) Throttle position sensor      (4) Engine control module (ECM)  
(2) Throttle position sensor 2 signal

#### 3. ENABLE CONDITIONS

Secondary Parameters	Enable Conditions
Battery voltage	$\geq 6 \text{ V}$

#### 4. GENERAL DRIVING CYCLE

Always perform the diagnosis continuously.

#### 5. DIAGNOSTIC METHOD

If the duration of time while the following conditions are met is longer than the time indicated, judge as NG.

##### Judgment Value

Malfunction Criteria	Threshold Value
Sensor 2 input voltage	$< 0.44 \text{ V}$

**Time Needed for Diagnosis:** 100 ms

**Malfunction Indicator Light Illumination:** Illuminates as soon as a malfunction occurs.

# Diagnostic Trouble Code (DTC) Detecting Criteria

GENERAL DESCRIPTION

## BZ:DTC P0223 THROTTLE/PEDAL POSITION SENSOR/SWITCH “B” CIRCUIT HIGH

### 1. OUTLINE OF DIAGNOSIS

Detect the open or short circuit of throttle position sensor 2.  
Judge as NG if out of specification.

### 2. COMPONENT DESCRIPTION

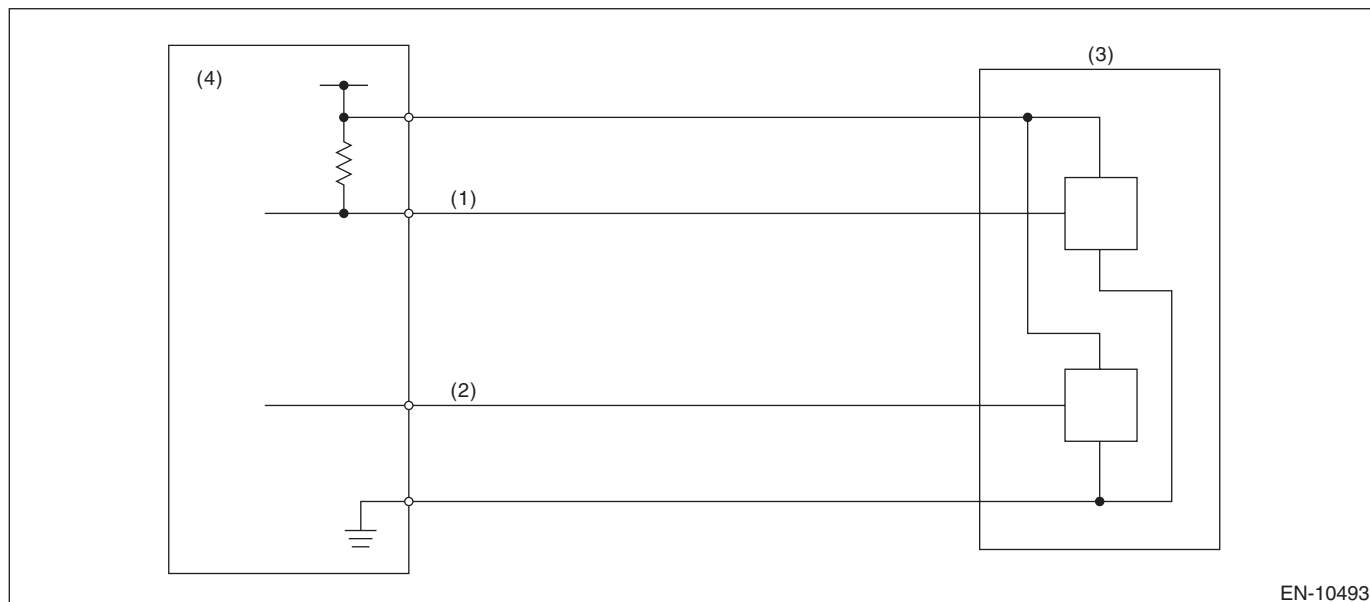

EN-10493

- (1) Throttle position sensor 1 signal      (3) Throttle position sensor      (4) Engine control module (ECM)  
(2) Throttle position sensor 2 signal

### 3. ENABLE CONDITIONS

Secondary Parameters	Enable Conditions
Battery voltage	$\geq 6 \text{ V}$

### 4. GENERAL DRIVING CYCLE

Always perform the diagnosis continuously.

### 5. DIAGNOSTIC METHOD

If the duration of time while the following conditions are met is longer than the time indicated, judge as NG.

#### Judgment Value

Malfunction Criteria	Threshold Value
Sensor 2 input voltage	$> 4.82 \text{ V}$

**Time Needed for Diagnosis:** 100 ms

**Malfunction Indicator Light Illumination:** Illuminates as soon as a malfunction occurs.

# Diagnostic Trouble Code (DTC) Detecting Criteria

## GENERAL DESCRIPTION

### CA:DTC P0230 FUEL PUMP PRIMARY CIRCUIT

#### 1. OUTLINE OF DIAGNOSIS

Detect the malfunction of fuel pump control unit.

Judge as NG when the NG signal is sent through a diagnostic line coming from the fuel pump control unit.

Fuel pump control unit detects the open or short circuit malfunction for each line, and then sends NG signals if one of them is found NG.

#### 2. COMPONENT DESCRIPTION

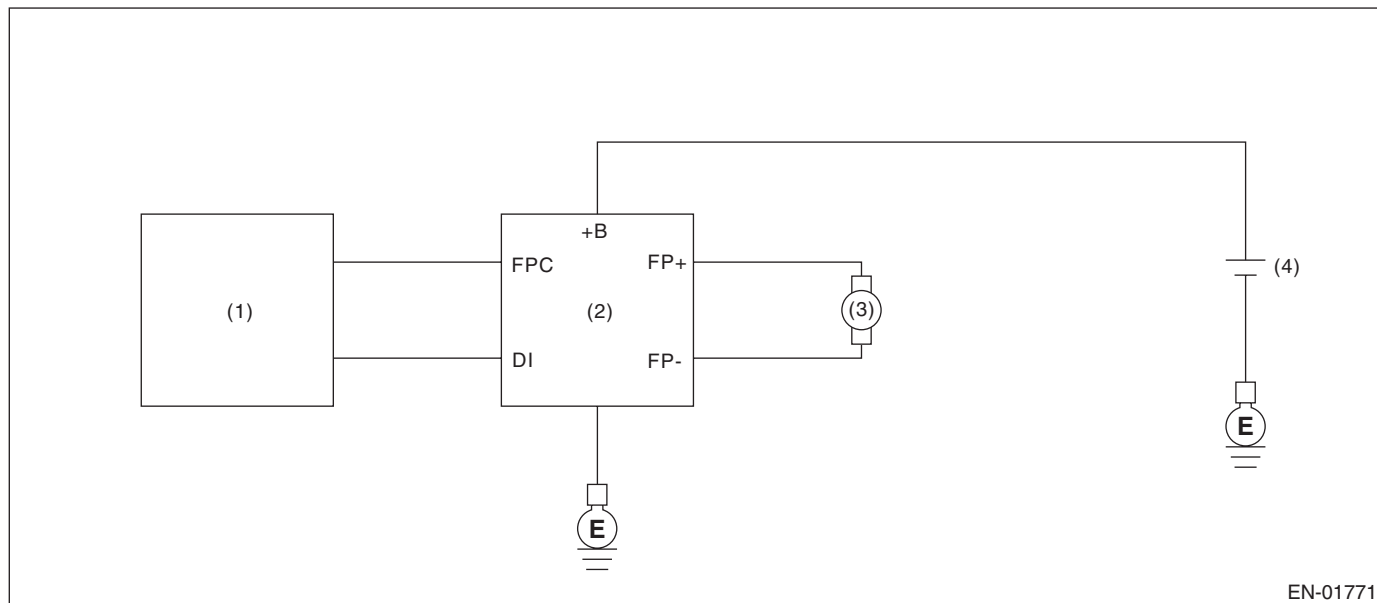

(1) Engine control module (ECM)

(3) Fuel pump

(4) Battery

(2) Fuel pump control unit

EN-01771

#### 3. ENABLE CONDITIONS

Secondary Parameters	Enable Conditions
Battery voltage	$\geq 8 \text{ V}$
Fuel level	$\geq 15\%$
Elapsed time after starting the engine	$\geq 180 \text{ s}$
Fuel pump controller control mode	ON

#### 4. GENERAL DRIVING CYCLE

Always perform the diagnosis continuously.

#### 5. DIAGNOSTIC METHOD

If the duration of time while the following conditions are met is longer than the time indicated, judge as NG.

##### Judgment Value

Malfunction Criteria	Threshold Value
Fuel pump control unit output diagnosis signal	$< 1.5 \text{ V}$

**Time Needed for Diagnosis:** 2520 ms

**Malfunction Indicator Light Illumination:** Illuminates when malfunction occurs in 2 continuous driving cycles.

# Diagnostic Trouble Code (DTC) Detecting Criteria

GENERAL DESCRIPTION

## CB:DTC P023F FUEL PUMP SECONDARY CIRCUIT/OPEN

### 1. OUTLINE OF DIAGNOSIS

Detect the malfunction of high pressure fuel pump circuit function.

Judge as NG when ECM detects any malfunction in the diagnostic items listed below.

Diagnostic item	Malfunction Criteria
Power supply short	ECM low side terminal voltage of the high pressure fuel pump circuit is high.
Ground short	ECM low side terminal voltage of the high pressure fuel pump circuit is low.
Open circuit	High pressure fuel pump current is low.
Overcurrent	High pressure fuel pump current is high.
Short circuit	The time when the high pressure fuel pump current reaches the target current is short.

### 2. ENABLE CONDITIONS

Secondary Parameters	Enable Conditions
Battery voltage	$\geq 9.4$ V
Engine speed	$> 0$ rpm
Elapsed time after fuel pump current shutdown (Only power supply short diagnosis and ground short diagnosis)	$\geq 3.15$ ms

### 3. GENERAL DRIVING CYCLE

Always perform the diagnosis continuously.

### 4. DIAGNOSTIC METHOD

If the duration of time while the following conditions are met is longer than the time indicated, judge as NG.

#### Diagnosis for Power Supply Short

##### Judgment Value

Malfunction Criteria	Threshold Value
Terminal voltage	$\geq 4.1$ V

#### Diagnosis for Ground Short

##### Judgment Value

Malfunction Criteria	Threshold Value
Terminal voltage	$\leq 0.8$ V

#### Diagnosis for Open Circuit

##### Judgment Value

Malfunction Criteria	Threshold Value
Fuel pump current	$\leq 0.5$ A

#### Diagnosis for Overcurrent

##### Judgment Value

Malfunction Criteria	Threshold Value
Fuel pump current	$\geq 22$ A

#### Diagnosis for Short Circuit

##### Judgment Value

Malfunction Criteria	Threshold Value
Time for reaching target current	$\leq 0.075$ ms

**Time Needed for Diagnosis:** TDC  $\times$  75 times

**Malfunction Indicator Light Illumination:** Illuminates as soon as a malfunction occurs.

# Diagnostic Trouble Code (DTC) Detecting Criteria

## GENERAL DESCRIPTION

### CC:DTC P0244 TURBO/SUPER CHARGER WASTEGATE SOLENOID "A" RANGE/PERFORMANCE

#### 1. OUTLINE OF DIAGNOSIS

Detect the malfunction of wastegate control solenoid valve function.  
Judge as NG when becoming high wastegate pressure.

#### 2. COMPONENT DESCRIPTION

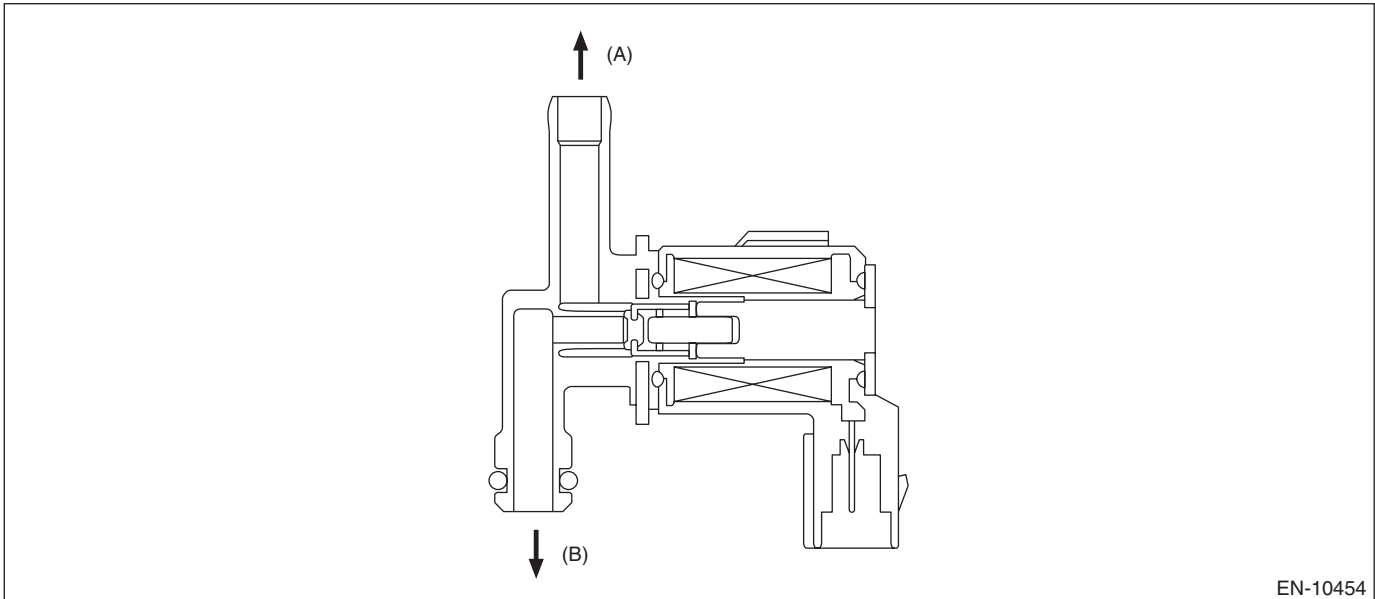

(A) Turbocharger

(B) Intake duct

#### 3. ENABLE CONDITIONS

Secondary Parameters	Enable Conditions
None	

#### 4. GENERAL DRIVING CYCLE

Always perform the diagnosis continuously.



# Diagnostic Trouble Code (DTC) Detecting Criteria

GENERAL DESCRIPTION

## 5. DIAGNOSTIC METHOD

If the duration of time while the following conditions are met is longer than the time indicated, judge as NG.

### Judgment Value

Malfunction Criteria	Threshold Value
Intake manifold pressure	> Value from Map

### Map

		Barometric pressure (kPa (mmHg, inHg))							
		64 (480, 18.9)	70.6 (529.5, 20.8)	77.3 (579.8, 22.8)	84 (630.1, 24.8)	90.6 (679.6, 26.8)	93.3 (699.8, 27.6)	96 (720.1, 28.3)	97.3 (729.8, 28.7)
Engine speed (rpm)	1600	159.7 (1197.9, 47.2)	159.7 (1197.9, 47.2)	159.7 (1197.9, 47.2)	159.7 (1197.9, 47.2)	159.7 (1197.9, 47.2)	159.7 (1197.9, 47.2)	159.7 (1197.9, 47.2)	159.7 (1197.9, 47.2)
	2400	223.7 (1677.9, 66.1)	223.7 (1677.9, 66.1)	223.7 (1677.9, 66.1)	223.7 (1677.9, 66.1)	223.7 (1677.9, 66.1)	223.7 (1677.9, 66.1)	223.7 (1677.9, 66.1)	223.7 (1677.9, 66.1)
	3200	219.2 (1644.1, 64.7)	223.3 (1674.9, 65.9)	229.6 (1722.1, 67.8)	233.7 (1752.9, 69)	233.7 (1752.9, 69)	233.7 (1752.9, 69)	233.7 (1752.9, 69)	233.7 (1752.9, 69)
	4000	204.3 (1532.4, 60.3)	210.7 (1580.4, 62.2)	220.4 (1653.1, 65.1)	236.4 (1773.2, 69.8)	240.7 (1805.4, 71.1)	240.7 (1805.4, 71.1)	240.7 (1805.4, 71.1)	240.7 (1805.4, 71.1)
	4800	190.9 (1431.9, 56.4)	201.9 (1514.4, 59.6)	213.5 (1601.4, 63)	234.7 (1760.4, 69.3)	245.7 (1842.9, 72.6)	245.7 (1842.9, 72.6)	245.7 (1842.9, 72.6)	245.7 (1842.9, 72.6)
	5600	155.1 (1163.3, 45.8)	176.5 (1323.9, 52.1)	187.2 (1404.1, 55.3)	208.6 (1564.6, 61.6)	219.3 (1644.9, 64.8)	234.3 (1757.4, 69.2)	240.7 (1805.4, 71.1)	240.7 (1805.4, 71.1)
kPa (mmHg, inHg)									

**Time Needed for Diagnosis:** 2000 ms

**Malfunction Indicator Light Illumination:** Illuminates as soon as a malfunction occurs.

# Diagnostic Trouble Code (DTC) Detecting Criteria

## GENERAL DESCRIPTION

### CD:DTC P0245 TURBO/SUPER CHARGER WASTEGATE SOLENOID “A” LOW

#### 1. OUTLINE OF DIAGNOSIS

Detect open or short circuit of the wastegate control solenoid valve.

Judge as NG when the terminal output voltage remains Low during outputting the duty signal.

#### 2. COMPONENT DESCRIPTION

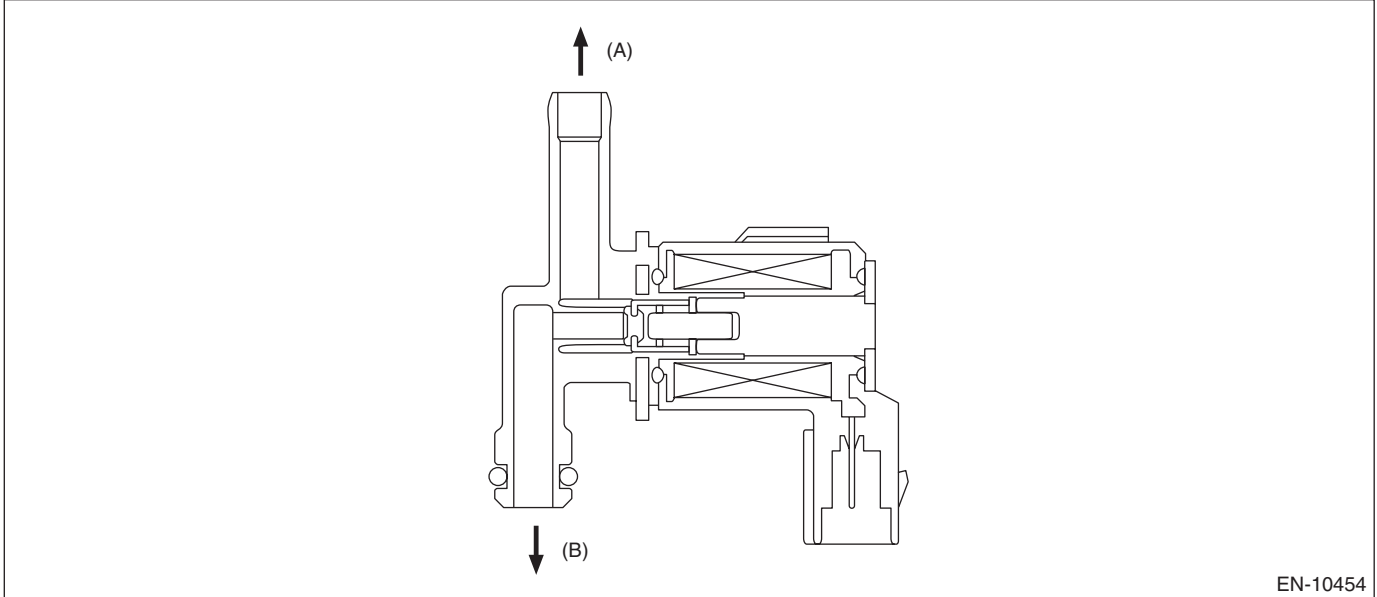

(A) Turbocharger

(B) Intake duct

#### 3. ENABLE CONDITIONS

Secondary Parameters	Enable Conditions
Battery voltage	$\geq 10.9 \text{ V}$
Duty ratio of wastegate control	$\leq 80\%$

#### 4. GENERAL DRIVING CYCLE

Always perform the diagnosis after starting the engine.

#### 5. DIAGNOSTIC METHOD

If the duration of time while the following conditions are met is longer than the time indicated, judge as NG.

##### Judgment Value

Malfunction Criteria	Threshold Value
Output voltage	$\leq 2.2 \text{ V}$

**Time Needed for Diagnosis:** 640 ms

**Malfunction Indicator Light Illumination:** Illuminates as soon as a malfunction occurs.

## CE:DTC P0246 TURBO/SUPER CHARGER WASTEGATE SOLENOID “A” HIGH

### 1. OUTLINE OF DIAGNOSIS

Detect open or short circuit of the wastegate control solenoid valve.  
Judge as NG when overcurrent is detected.

### 2. COMPONENT DESCRIPTION

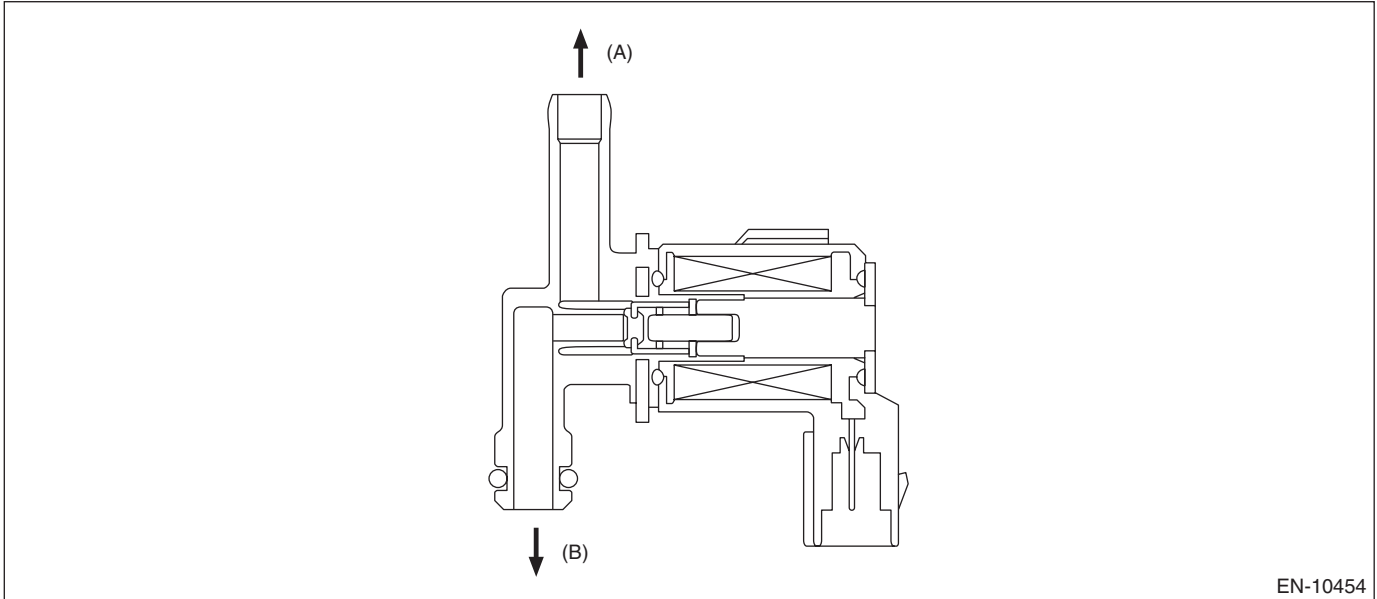

EN-10454

(A) Turbocharger

(B) Intake duct

### 3. ENABLE CONDITIONS

Secondary Parameters	Enable Conditions
Battery voltage	≥ 10.9 V
Duty ratio of wastegate control	≥ 20%

### 4. GENERAL DRIVING CYCLE

Always perform the diagnosis after starting the engine.

### 5. DIAGNOSTIC METHOD

If the duration of time while the following conditions are met is longer than the time indicated, judge as NG.

#### Judgment Value

Malfunction Criteria	Threshold Value
Output current	≥ 17 A

**Time Needed for Diagnosis:** 2250 ms

**Malfunction Indicator Light Illumination:** Illuminates as soon as a malfunction occurs.

## CF:DTC P0300 RANDOM/MULTIPLE CYLINDER MISFIRE DETECTED

### 1. OUTLINE OF DIAGNOSIS

NOTE:

For the detection standard, refer to DTC P0301. <Ref. to GD(w/o STI)-102, DTC P0301 CYLINDER 1 MISFIRE DETECTED, Diagnostic Trouble Code (DTC) Detecting Criteria.>

# Diagnostic Trouble Code (DTC) Detecting Criteria

## GENERAL DESCRIPTION

### CG:DTC P0301 CYLINDER 1 MISFIRE DETECTED

#### 1. OUTLINE OF DIAGNOSIS

Detect the presence of misfire occurrence. (Revolution fluctuation method)

Monitoring Misfire which influences exhaust deterioration (1.5 times of FTP) and catalyst damage is made obligatory by the law. Misfire affecting these two has two patterns below:

- Intermittent misfire (The same cylinder misfires in random, or different cylinders misfire in random.): FTP 1.5 times misfire
- Every time misfire (The same cylinder misfires every time.): FTP 1.5 times misfire, Catalyst damage misfire

The following detecting methods are adopted for these detection.

1) Intermittent misfire: FTP 1.5 times misfire

- 180° Interval Difference Method
- 360° Interval Difference Method (whole range)
- 720° Interval Difference Method (3,000 rpm or more)

2) Misfire every time: FTP 1.5 times misfire, Catalyst damage misfire

- 360° Interval Difference Method

#### 2. ENABLE CONDITIONS

Secondary Parameters	Enable Conditions
Fuel shut-off function	Not in operation
Fuel level	≥ 9 L (2.38 US gal, 1.98 Imp gal)
Vehicle dynamic control or AT torque control	Not in operation
Second diagnosis of P0441	Not in operation
Engine speed	400 rpm — 6000 rpm
Intake manifold pressure	<ul style="list-style-type: none"><li>• Normal ignition ≥ 19.1 — 47 kPa (143.3 — 352.5 mmHg, 5.6 — 13.9 inHg) (Changing depending on engine speed and atmosphere pressure)</li><li>• Idling ignition ≥ 19.3 — 46.2 kPa (144.8 — 346.5 mmHg, 5.7 — 13.6 inHg) (Changing depending on engine speed and atmosphere pressure)</li></ul>

#### 3. GENERAL DRIVING CYCLE

- If conditions are met, it is possible to detect the misfires from idling to high engine speed. However, in case any engine load or breakage occurs, perform with the engine at idle.
- Perform the diagnosis continuously.

# Diagnostic Trouble Code (DTC) Detecting Criteria

GENERAL DESCRIPTION

## 4. DIAGNOSTIC METHOD

When a misfire occurs, the engine speed will decrease and the crankshaft position speed will change. Calculate the interval difference value (diagnostic value) from crankshaft position speed by the following formula, and judge whether a misfire is occurring or not comparing the calculated result with judgment value. Count the number of misfires, if the misfire ratio is higher during 1000 revs. or 200 revs., judge corresponding cylinders as NG.

Diagnostic value calculation (Calculate from angle speed) →	Misfire detection every single ignition (Compare diagnostic value with judgment value) →	NG judgment (Misfire occurrence judgment required by the law) (Compare number of misfire with judgment value)
	<ul style="list-style-type: none"> <li>• 180° Interval Difference Method</li> <li>• 360° Interval Difference Method</li> <li>• 720° Interval Difference Method</li> </ul>	<ul style="list-style-type: none"> <li>• FTP 1.5 times misfire NG judgment</li> <li>• Catalyst damage misfire NG judgment</li> </ul>

As shown in the following figure, pick a cylinder as the standard and name it omg 0. And the former crankshaft position speed is named omg 1, the second former crankshaft position speed is named omg 2, the third is named omg 3, etc.

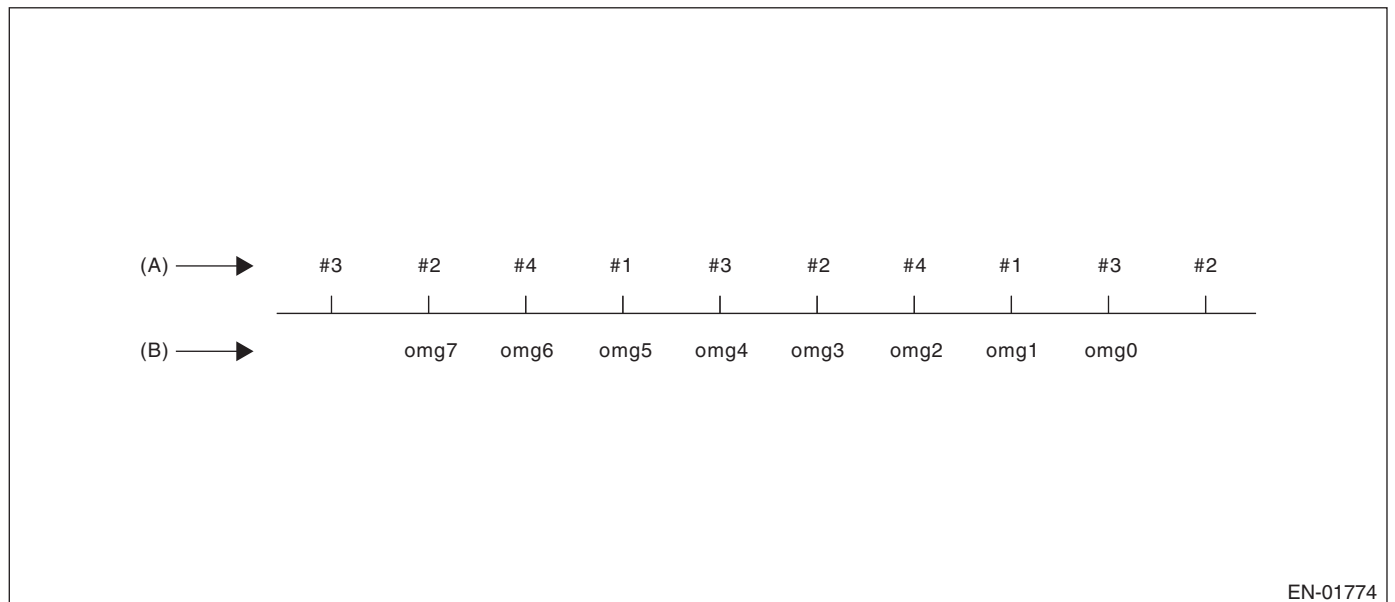

EN-01774

(A) Ignition order

(B) Crankshaft position speed

# Diagnostic Trouble Code (DTC) Detecting Criteria

## GENERAL DESCRIPTION

### 180° Interval Difference Method

Diagnostic value	$\text{domg } 180 = (\text{omg } 0 - \text{omg } 1) - (\text{omg } 1 - \text{omg } 2)$
Judge as a misfire in the following cases.	
<ul style="list-style-type: none"><li>• <math>\text{domg } 180 \geq \text{judgment value of positive side}</math></li><li>• <math>\text{domg } 180 \leq \text{judgment value of negative side}</math></li></ul> (Diagnostic value before 180° CA)	

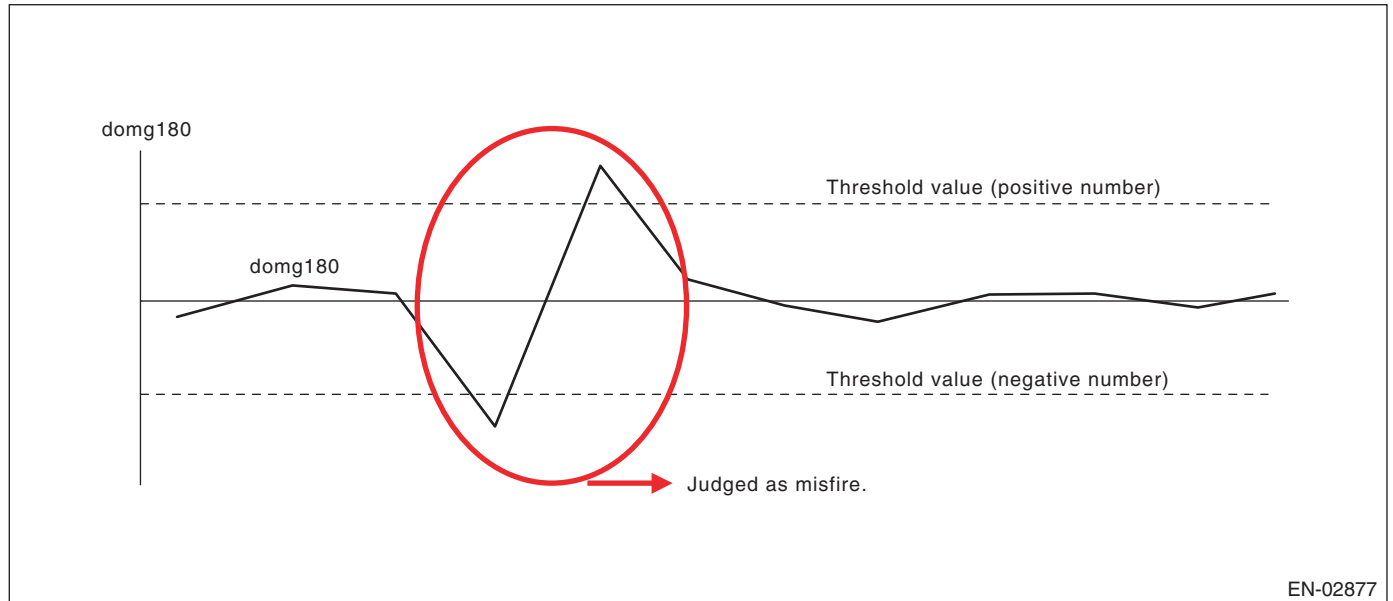

### 360° Interval Difference Method

Diagnostic value	$\text{domg } 360 = (\text{omg } 1 - \text{omg } 0) - (\text{omg } 3 - \text{omg } 2)$
Misfire judgment	$\text{domg } 360 > \text{Judgment value} \rightarrow \text{Judge as misfire}$

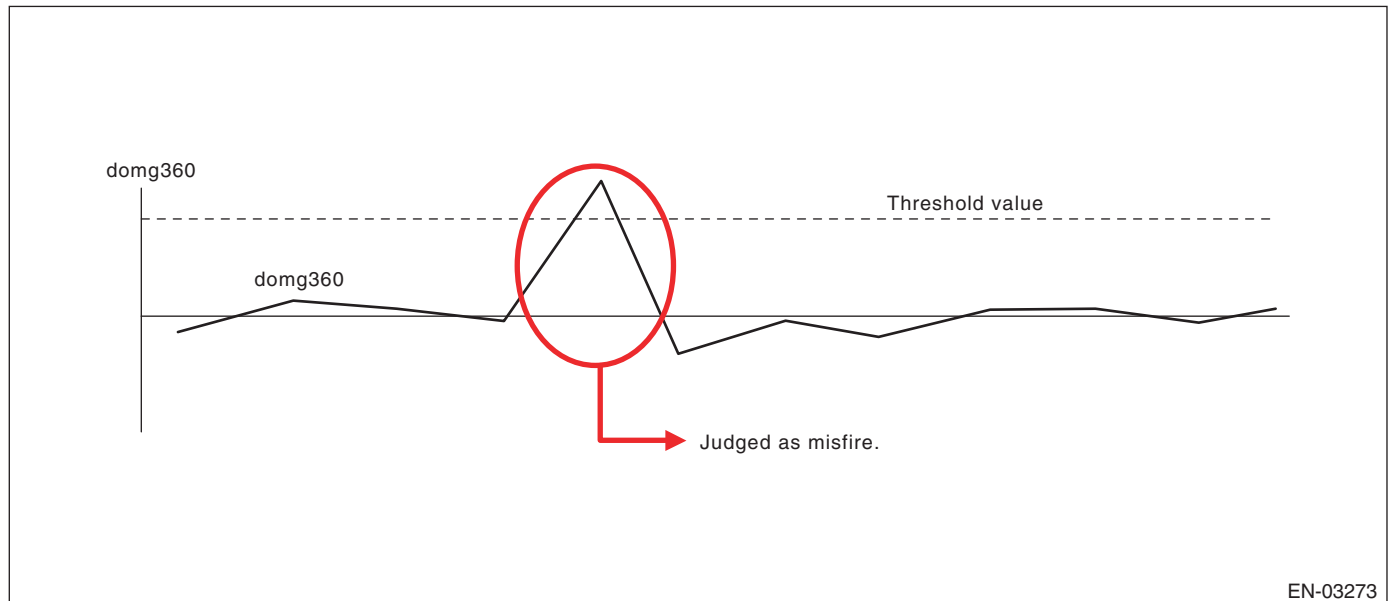

# Diagnostic Trouble Code (DTC) Detecting Criteria

GENERAL DESCRIPTION

## 720° Interval Difference Method

Diagnostic value	$\text{domg 720} = (\text{omg 0} - \text{omg 1}) - (\text{omg 4} - \text{omg 5})$
Judge as a misfire in the following cases.	
<ul style="list-style-type: none"> <li>• <math>\text{domg 720} \geq \text{judgment value of positive side}</math></li> <li>• <math>\text{domg 720} \leq \text{judgment value of negative side}</math></li> </ul> (Diagnostic value before 180° CA)	

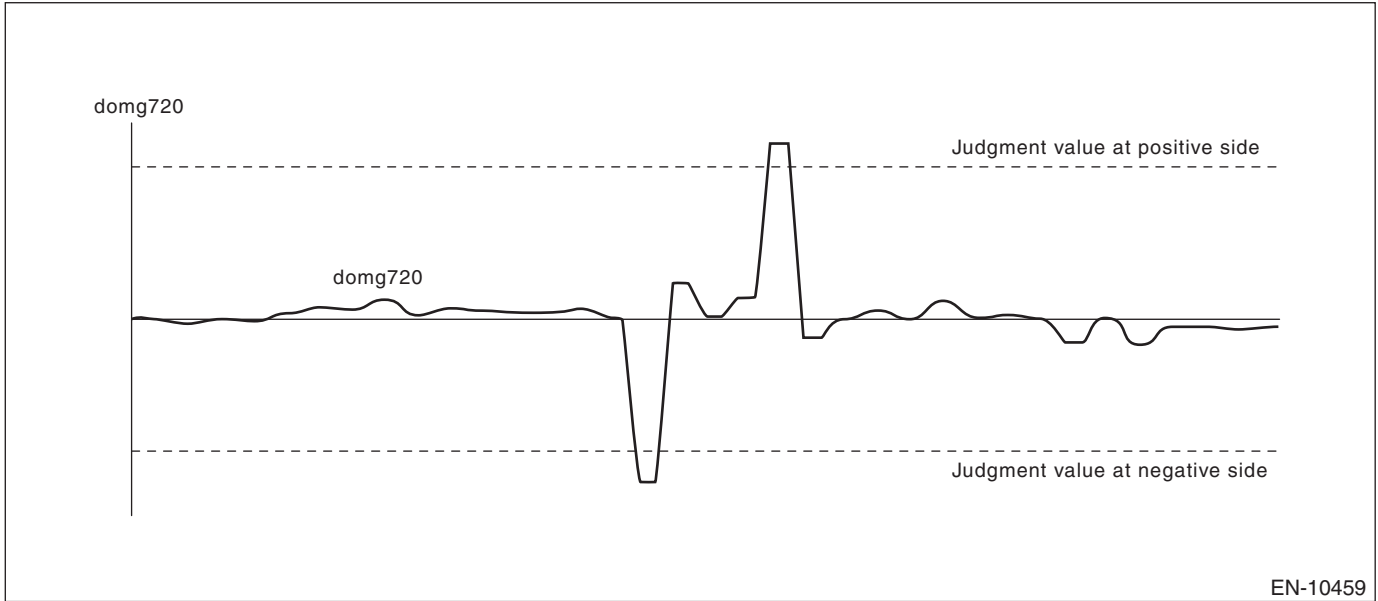

- **FTP 1.5 times misfire (Misfire occurrence level which influences exhaust gas)**

**Judgment Value (Judge that malfunction occurs when the misfire ratio is high in 1000 engine revs.)**

Malfunction Criteria	Threshold Value
FTP emission diagnostic value	$\geq 37 \times 100/2000\%$ in 1000 revs.

**Time Needed for Diagnosis:** 1000 engine revs.

**Malfunction Indicator Light Illumination:** Illuminates when malfunction occurs in 2 continuous driving cycles.

# Diagnostic Trouble Code (DTC) Detecting Criteria

## GENERAL DESCRIPTION

- **Catalyst damage misfire (Misfire occurrence level damaging catalyst)**

### Judgment Value

Malfunction Criteria	Threshold Value
Catalyst damage misfire diagnostic value	≥ Value from Map

### Map

		Charging efficiency (%)											
		15	30	45	60	75	90	105	120	135	150	165	180
Engine speed (rpm)	700	25	25	—	—	—	—	—	—	—	—	—	—
	1000	25	25	25	25	25	25	—	—	—	—	—	—
	1500	25	25	25	25	16.75	16.75	16.75	—	—	—	—	—
	2000	25	25	25	25	16.75	14.25	12.5	—	—	—	—	—
	2500	25	25	19.75	17	14.25	12.5	11	11	—	—	—	—
	3000	25	25	19.75	17	14.25	12	10.5	10	7.75	6	—	—
	3500	25	25	19.75	17	14.25	11	9	7.75	6	5	5	5
	4000	—	25	19.75	17	14.25	11	8.25	6.25	5	5	5	5
	4500	—	25	17.5	14.25	12.5	9	6.75	5	5	5	5	5
	5000	—	25	16.75	12.5	11	8.25	6	5	5	5	5	5
	5500	—	25	16	12	11	7.25	5	5	5	5	5	5
	6000	—	25	15	11	11	6	5	5	5	5	5	5

**Time Needed for Diagnosis:** 200 engine revs.

**Malfunction Indicator Light Illumination:** Illuminates as soon as a malfunction occurs.

## CH:DTC P0302 CYLINDER 2 MISFIRE DETECTED

### 1. OUTLINE OF DIAGNOSIS

NOTE:

For the detection standard, refer to DTC P0301. <Ref. to GD(w/o STI)-102, DTC P0301 CYLINDER 1 MISFIRE DETECTED, Diagnostic Trouble Code (DTC) Detecting Criteria.>

## CI: DTC P0303 CYLINDER 3 MISFIRE DETECTED

### 1. OUTLINE OF DIAGNOSIS

NOTE:

For the detection standard, refer to DTC P0301. <Ref. to GD(w/o STI)-102, DTC P0301 CYLINDER 1 MISFIRE DETECTED, Diagnostic Trouble Code (DTC) Detecting Criteria.>

## CJ:DTC P0304 CYLINDER 4 MISFIRE DETECTED

### 1. OUTLINE OF DIAGNOSIS

NOTE:

For the detection standard, refer to DTC P0301. <Ref. to GD(w/o STI)-102, DTC P0301 CYLINDER 1 MISFIRE DETECTED, Diagnostic Trouble Code (DTC) Detecting Criteria.>



# Diagnostic Trouble Code (DTC) Detecting Criteria

GENERAL DESCRIPTION

## CK:DTC P0327 KNOCK SENSOR 1 CIRCUIT LOW (BANK 1 OR SINGLE SENSOR)

### 1. OUTLINE OF DIAGNOSIS

Detect the open or short circuit of knock sensor.  
Judge as NG if out of specification.

### 2. COMPONENT DESCRIPTION

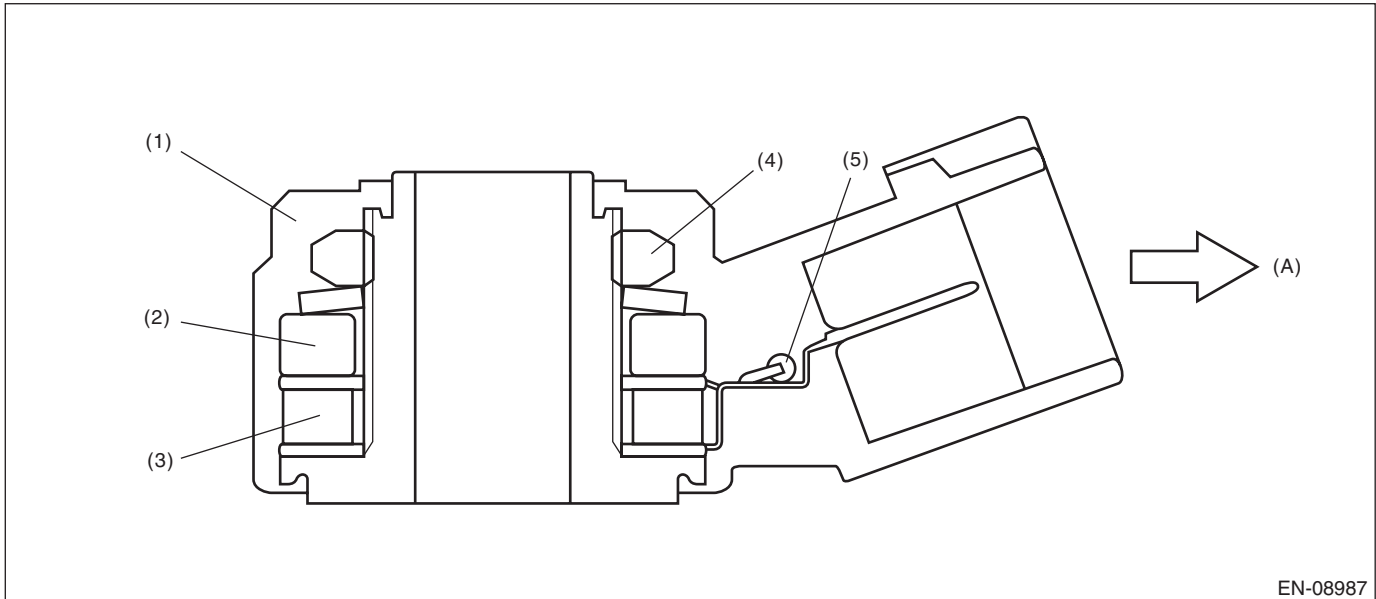

(A) To knock sensor harness

- |            |                           |                |
|------------|---------------------------|----------------|
| (1) Case   | (3) Piezoelectric element | (5) Resistance |
| (2) Weight | (4) Nut                   |                |

### 3. ENABLE CONDITIONS

Secondary Parameters	Enable Conditions
None	

### 4. GENERAL DRIVING CYCLE

Always perform the diagnosis continuously.

### 5. DIAGNOSTIC METHOD

If the duration of time while the following conditions are met is longer than the time indicated, judge as NG.

#### Judgment Value

Malfunction Criteria	Threshold Value
Output voltage	< 0.22 V

**Time Needed for Diagnosis:** 1000 ms

**Malfunction Indicator Light Illumination:** Illuminates as soon as a malfunction occurs.

# Diagnostic Trouble Code (DTC) Detecting Criteria

## GENERAL DESCRIPTION

### CL:DTC P0328 KNOCK SENSOR 1 CIRCUIT HIGH (BANK 1 OR SINGLE SENSOR)

#### 1. OUTLINE OF DIAGNOSIS

Detect the open or short circuit of knock sensor.

Judge as NG if out of specification.

#### 2. COMPONENT DESCRIPTION

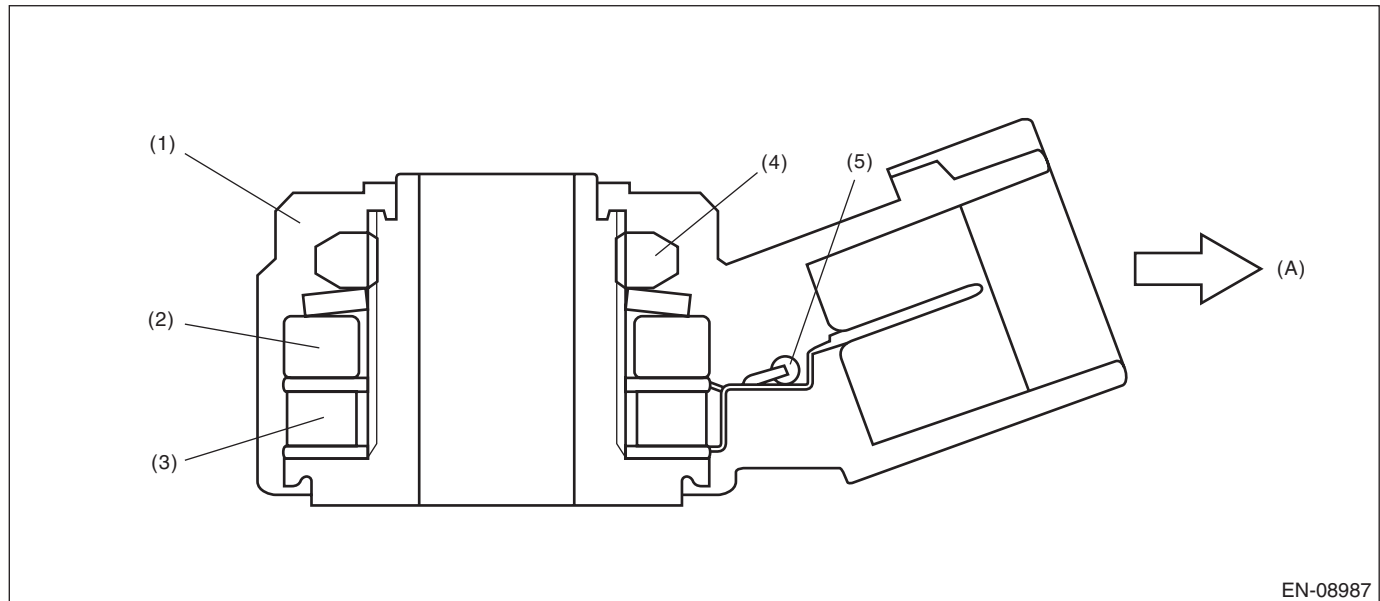

(A) To knock sensor harness

(1) Case

(3) Piezoelectric element

(5) Resistance

(2) Weight

(4) Nut

#### 3. ENABLE CONDITIONS

Secondary Parameters	Enable Conditions
None	

#### 4. GENERAL DRIVING CYCLE

Always perform the diagnosis continuously.

#### 5. DIAGNOSTIC METHOD

If the duration of time while the following conditions are met is longer than the time indicated, judge as NG.

##### Judgment Value

Malfunction Criteria	Threshold Value
Output voltage	> 4.73 V

**Time Needed for Diagnosis:** 1000 ms

**Malfunction Indicator Light Illumination:** Illuminates as soon as a malfunction occurs.

# Diagnostic Trouble Code (DTC) Detecting Criteria

GENERAL DESCRIPTION

## CM:DTC P0332 KNOCK SENSOR 2 CIRCUIT LOW (BANK 2)

### 1. OUTLINE OF DIAGNOSIS

Detect the open or short circuit of knock sensor.  
Judge as NG if out of specification.

### 2. COMPONENT DESCRIPTION

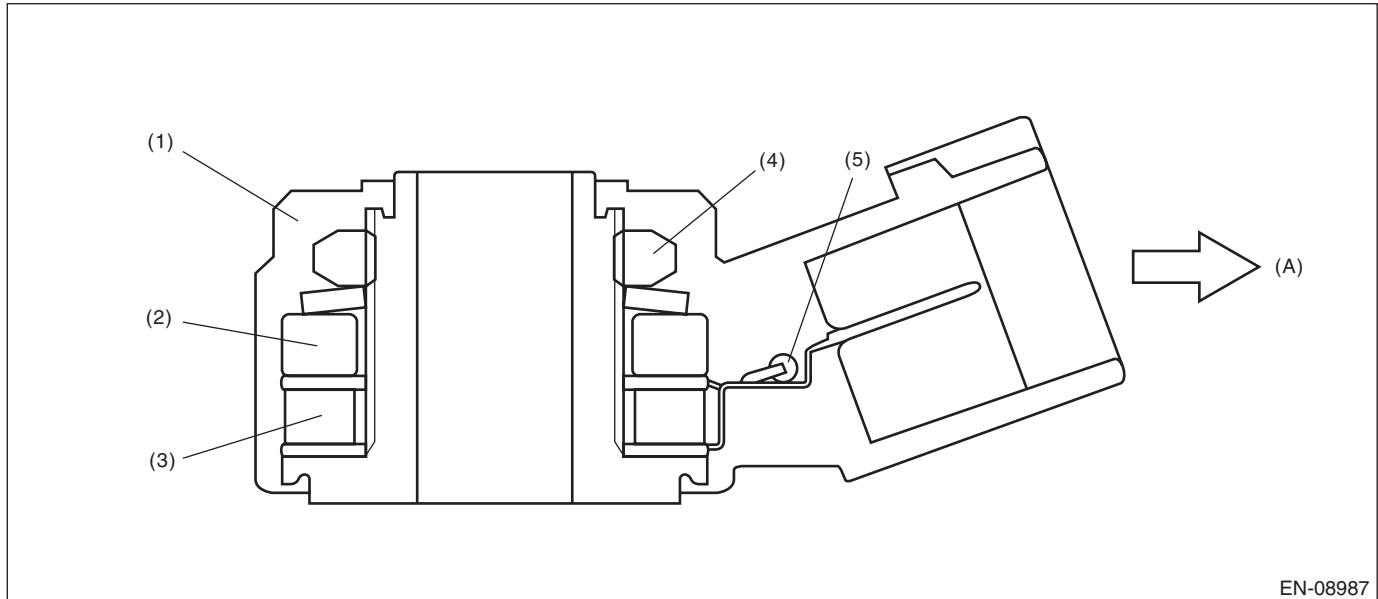

(A) To knock sensor harness

(1) Case

(2) Weight

(3) Piezoelectric element

(4) Nut

(5) Resistance

### 3. ENABLE CONDITIONS

Secondary Parameters	Enable Conditions
None	

### 4. GENERAL DRIVING CYCLE

Always perform the diagnosis continuously.

### 5. DIAGNOSTIC METHOD

If the duration of time while the following conditions are met is longer than the time indicated, judge as NG.

#### Judgment Value

Malfunction Criteria	Threshold Value
Output voltage	< 0.22 V

**Time Needed for Diagnosis:** 1000 ms

**Malfunction Indicator Light Illumination:** Illuminates as soon as a malfunction occurs.

# Diagnostic Trouble Code (DTC) Detecting Criteria

## GENERAL DESCRIPTION

### CN:DTC P0333 KNOCK SENSOR 2 CIRCUIT HIGH (BANK 2)

#### 1. OUTLINE OF DIAGNOSIS

Detect the open or short circuit of knock sensor.  
Judge as NG if out of specification.

#### 2. COMPONENT DESCRIPTION

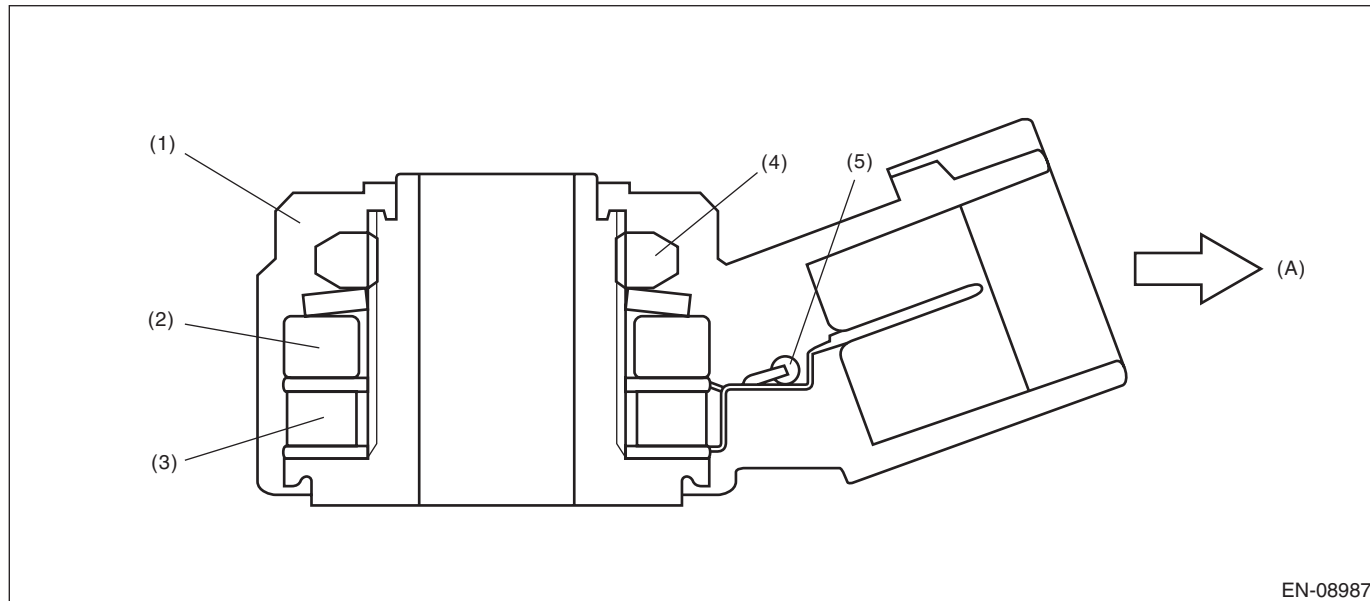

(A) To knock sensor harness

- |            |                           |                |
|------------|---------------------------|----------------|
| (1) Case   | (3) Piezoelectric element | (5) Resistance |
| (2) Weight | (4) Nut                   |                |

#### 3. ENABLE CONDITIONS

Secondary Parameters	Enable Conditions
None	

#### 4. GENERAL DRIVING CYCLE

Always perform the diagnosis continuously.

#### 5. DIAGNOSTIC METHOD

If the duration of time while the following conditions are met is longer than the time indicated, judge as NG.

##### Judgment Value

Malfunction Criteria	Threshold Value
Output voltage	> 4.73 V

**Time Needed for Diagnosis:** 1000 ms

**Malfunction Indicator Light Illumination:** Illuminates as soon as a malfunction occurs.

## CO:DTC P0335 CRANKSHAFT POSITION SENSOR "A" CIRCUIT

### 1. OUTLINE OF DIAGNOSIS

Detect the open or short circuit of the crankshaft position sensor.

Judge as NG when the crank signal is not input even though the starter was rotated.

### 2. COMPONENT DESCRIPTION

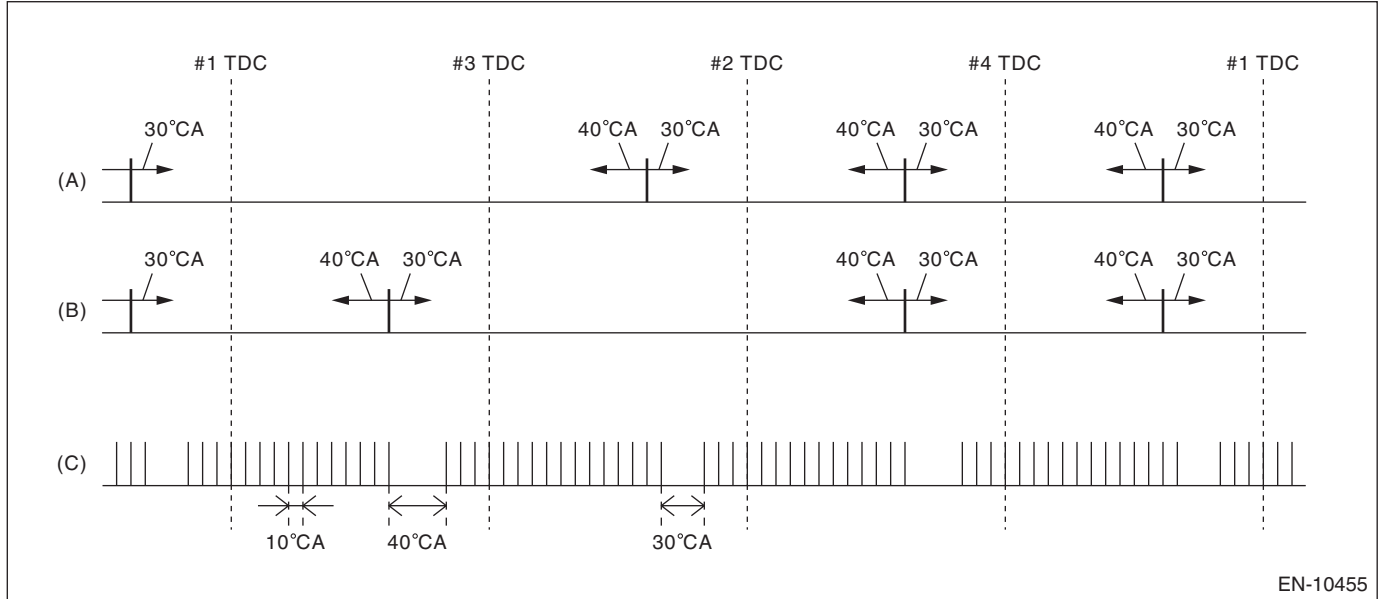

EN-10455

(A) Intake cam signal RH

(B) Intake cam signal LH

(C) Crankshaft signal

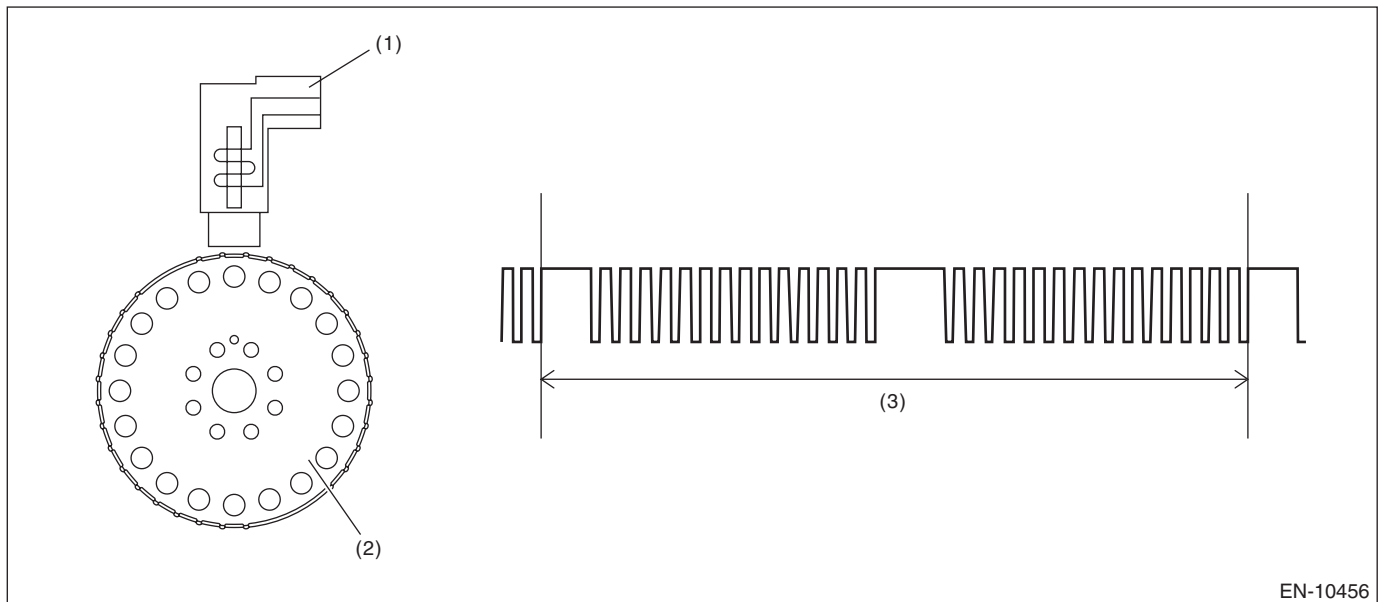

EN-10456

(1) Crankshaft position sensor

(2) Crankshaft position sensor plate

(3) Crank shaft one revolution

### 3. ENABLE CONDITIONS

Secondary Parameters	Enable Conditions
Battery voltage	≥ 8 V

### 4. GENERAL DRIVING CYCLE

Always perform the diagnosis continuously.

## Diagnostic Trouble Code (DTC) Detecting Criteria

### GENERAL DESCRIPTION

---

#### 5. DIAGNOSTIC METHOD

If the duration of time while the following conditions are met is longer than the time indicated, judge as NG.

#### Judgment Value

Malfunction Criteria	Threshold Value
Number of crankshaft position sensor signals during cranking	= 0

**Time Needed for Diagnosis:** 3000 ms

**Malfunction Indicator Light Illumination:** Illuminates as soon as a malfunction occurs.

# Diagnostic Trouble Code (DTC) Detecting Criteria

GENERAL DESCRIPTION

## CP:DTC P0336 CRANKSHAFT POSITION SENSOR "A" CIRCUIT RANGE/PERFORMANCE

### 1. OUTLINE OF DIAGNOSIS

Detect for faults in crankshaft position sensor output properties.

Judge as NG when there is a problem in the number of crankshaft signals for every revolution of crankshaft.

### 2. COMPONENT DESCRIPTION

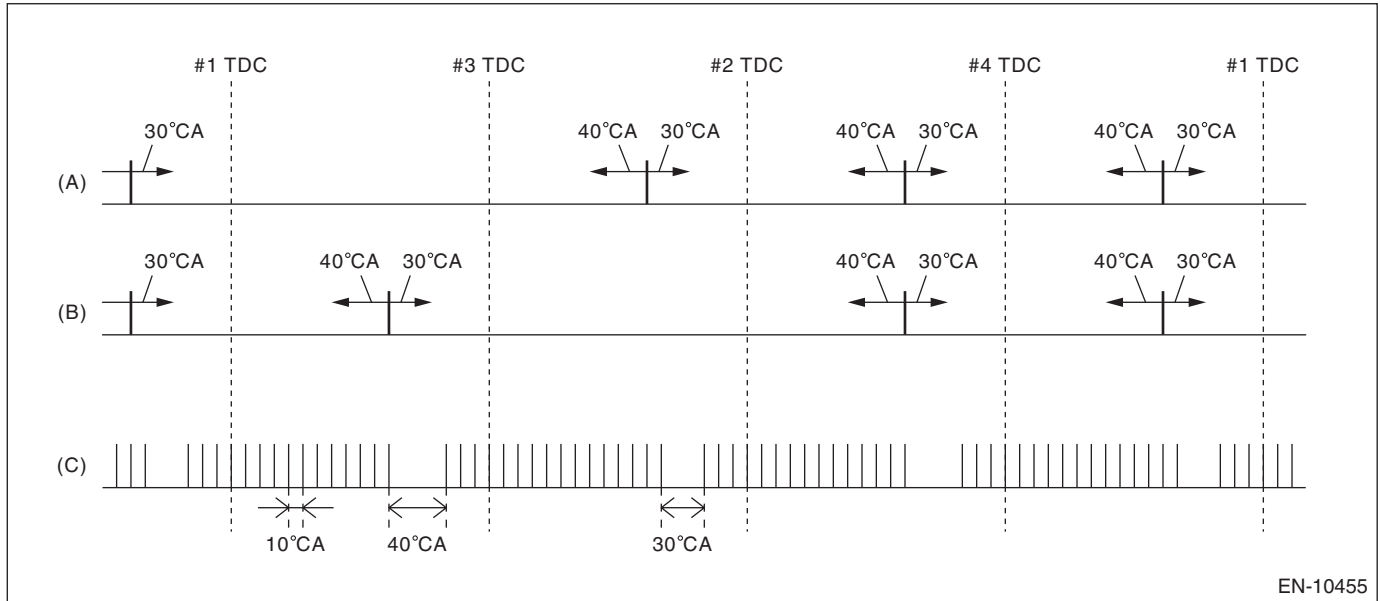

(A) Intake cam signal RH

(B) Intake cam signal LH

(C) Crankshaft signal

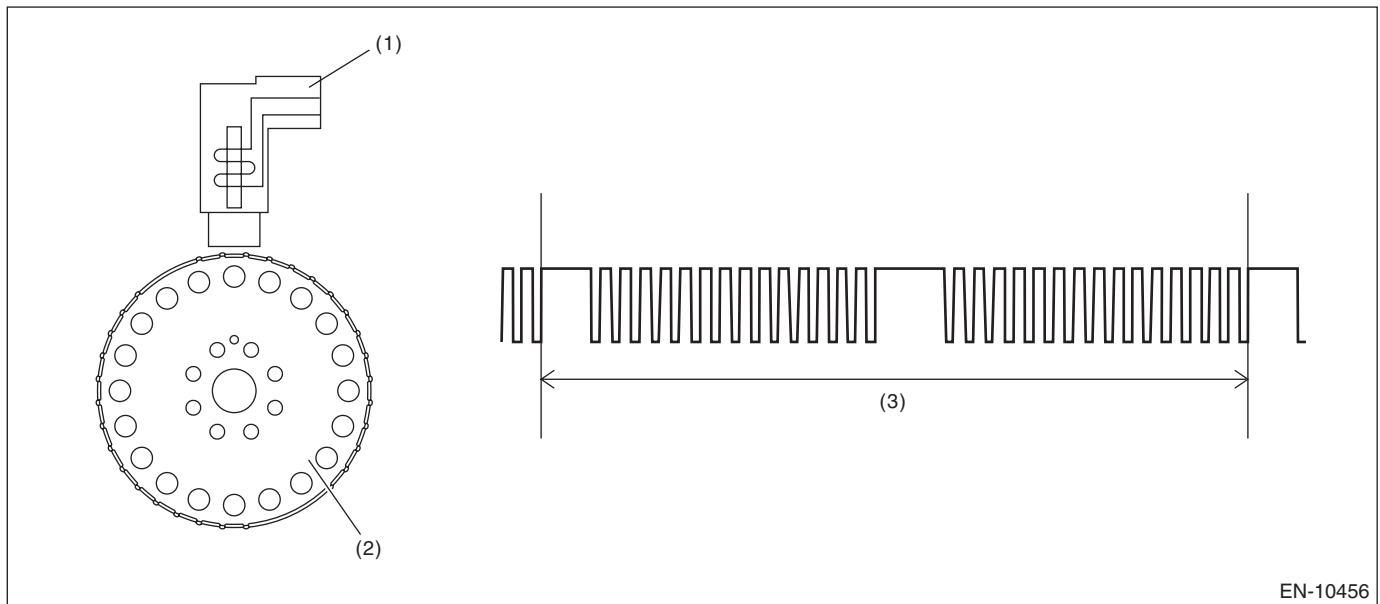

(1) Crankshaft position sensor

(2) Crankshaft position sensor plate

(3) Crank shaft one revolution

### 3. ENABLE CONDITIONS

Secondary Parameters	Enable Conditions
Battery voltage	≥ 10.9 V

# Diagnostic Trouble Code (DTC) Detecting Criteria

## GENERAL DESCRIPTION

---

### 4. GENERAL DRIVING CYCLE

Always perform the diagnosis continuously.

### 5. DIAGNOSTIC METHOD

Judge as NG when the following conditions are established.

#### Diagnosis 1

##### Judgment Value

Malfunction Criteria	Threshold Value
Amount of crank sensor signal during 0.5 rev of crankshaft	< 14 or ≥ 20

#### Diagnosis 2

##### Judgment Value

Malfunction Criteria	Threshold Value
$ (Present\ value\ of\ diagnosis\ 1) - (Previous\ value\ of\ diagnosis\ 1) $	$\neq 1$

**Time Needed for Diagnosis:** 10 engine revs.

**Malfunction Indicator Light Illumination:** Illuminates when malfunction occurs in 2 continuous driving cycles.



# Diagnostic Trouble Code (DTC) Detecting Criteria

GENERAL DESCRIPTION

## CQ:DTC P0340 CAMSHAFT POSITION SENSOR "A" CIRCUIT (BANK 1 OR SINGLE SENSOR)

### 1. OUTLINE OF DIAGNOSIS

Detect the open or short circuit of the camshaft position sensor.

When there is no camshaft position signal input continuously, judge as NG.

### 2. COMPONENT DESCRIPTION

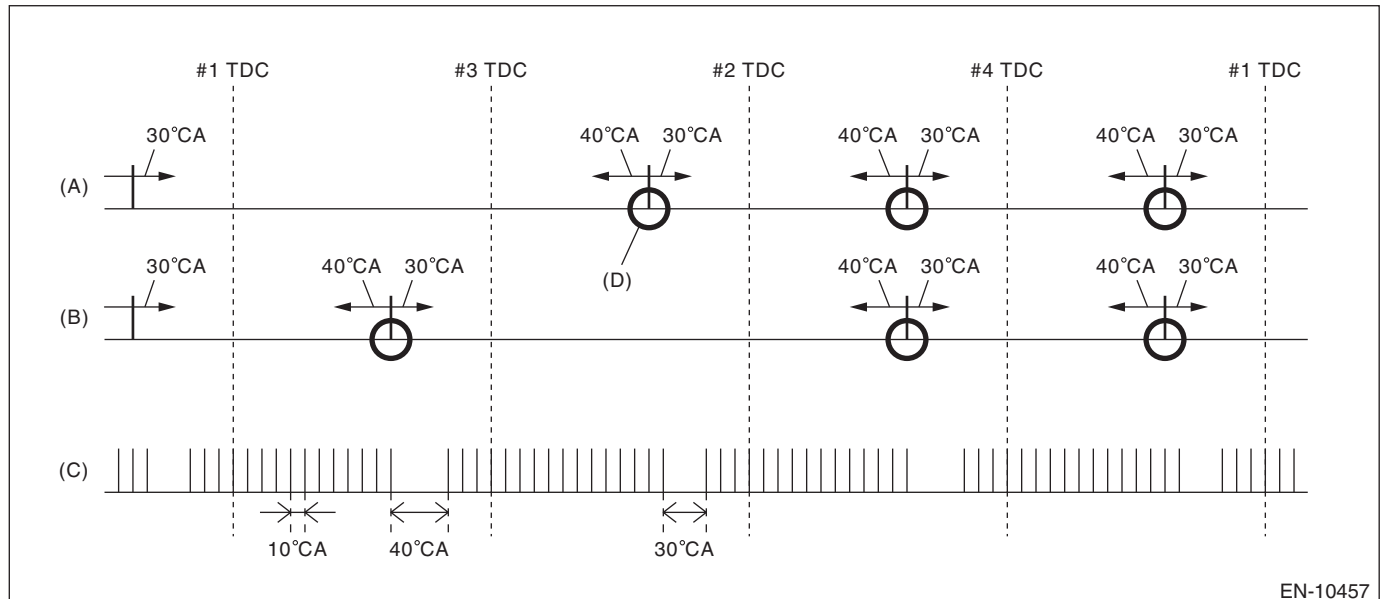

EN-10457

- (A) Intake cam signal RH  
 (B) Intake cam signal LH  
 (C) Crankshaft signal  
 (D) Camshaft position signal: When normal, there will be 3 camshaft position signals for every 2 crankshaft revolutions.

### 3. ENABLE CONDITIONS

#### Diagnosis 1

Secondary Parameters	Enable Conditions
Battery voltage	$\geq 8 \text{ V}$

#### Diagnosis 2

Secondary Parameters	Enable Conditions
Battery voltage	$\geq 8 \text{ V}$
Elapsed time after starting the engine	$\geq 200 \text{ ms}$

### 4. GENERAL DRIVING CYCLE

**Diagnosis 1:** Perform the diagnosis only once.

**Diagnosis 2:** Always perform the diagnosis continuously.

# Diagnostic Trouble Code (DTC) Detecting Criteria

## GENERAL DESCRIPTION

---

### 5. DIAGNOSTIC METHOD

#### Diagnosis 1

Judge as NG when no input status of camshaft position sensor signal continues for 3 sec. during cranking.

#### Judgment Value

Malfunction Criteria	Threshold Value
Number of camshaft position sensor signals during cranking	= 0

**Time Needed for Diagnosis:** 3 seconds

#### Diagnosis 2

If the duration of time while the following conditions are met is longer than the time indicated, judge as NG.

#### Judgment Value

Malfunction Criteria	Threshold Value
Amount of camshaft sensor signal during 1.5 revs of crankshaft	= 0

**Time Needed for Diagnosis:** 6 engine revs.

**Malfunction Indicator Light Illumination:** Illuminates as soon as a malfunction occurs.

# Diagnostic Trouble Code (DTC) Detecting Criteria

GENERAL DESCRIPTION

## CR:DTC P0341 CAMSHAFT POSITION SENSOR "A" CIRCUIT RANGE/PERFORMANCE (BANK 1 OR SINGLE SENSOR)

### 1. OUTLINE OF DIAGNOSIS

Detect the malfunction of camshaft position sensor property.  
Judge as NG when the number of camshaft signals remains abnormal.

### 2. COMPONENT DESCRIPTION

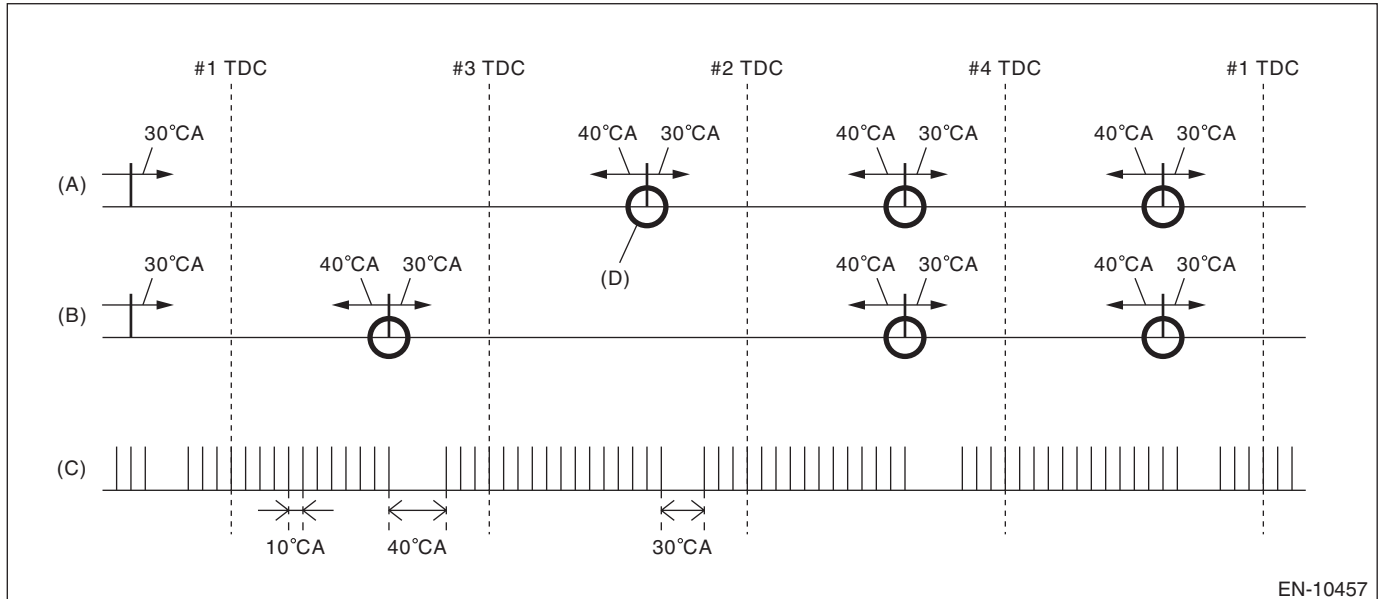

EN-10457

- (A) Intake cam signal RH                      (B) Intake cam signal LH                      (C) Crankshaft signal  
(D) Camshaft position signal: When normal, there will be 3 camshaft position signals for every 2 crankshaft revolutions.

### 3. ENABLE CONDITIONS

Secondary Parameters	Enable Conditions
Battery voltage	≥ 8 V

### 4. GENERAL DRIVING CYCLE

Always perform the diagnosis continuously.

### 5. DIAGNOSTIC METHOD

Judge as NG when the condition continues where the number of camshaft position sensor signals are not 3 times during 2 revs of crankshaft.

#### Judgment Value

Malfunction Criteria	Threshold Value
Amount of camshaft sensor signal during 2 revs of crankshaft	≠ 3 times

**Time Needed for Diagnosis:** Engine two revolutions × 4 times

**Malfunction Indicator Light Illumination:** Illuminates as soon as a malfunction occurs.

## Diagnostic Trouble Code (DTC) Detecting Criteria

### GENERAL DESCRIPTION

---

#### **CS:DTC P0345 CAMSHAFT POSITION SENSOR "A" CIRCUIT (BANK 2)**

##### **1. OUTLINE OF DIAGNOSIS**

###### NOTE:

For the detection standard, refer to DTC P0340. <Ref. to GD(w/o STI)-115, DTC P0340 CAMSHAFT POSITION SENSOR "A" CIRCUIT (BANK 1 OR SINGLE SENSOR), Diagnostic Trouble Code (DTC) Detecting Criteria.>

#### **CT:DTC P0346 CAMSHAFT POSITION SENSOR "A" CIRCUIT RANGE/PERFORMANCE (BANK 2)**

##### **1. OUTLINE OF DIAGNOSIS**

###### NOTE:

For the detection standard, refer to DTC P0341. <Ref. to GD(w/o STI)-117, DTC P0341 CAMSHAFT POSITION SENSOR "A" CIRCUIT RANGE/PERFORMANCE (BANK 1 OR SINGLE SENSOR), Diagnostic Trouble Code (DTC) Detecting Criteria.>

# Diagnostic Trouble Code (DTC) Detecting Criteria

GENERAL DESCRIPTION

## CU:DTC P0351 IGNITION COIL A PRIMARY/SECONDARY CIRCUIT

### 1. OUTLINE OF DIAGNOSIS

Based on the self-diagnostic result of the ignition coil driving IC, judge the ignition coil driving circuit as normal or abnormal.

The ignition coil driving IC detects “no ignition” status as a malfunction.

### 2. ENABLE CONDITIONS

Secondary Parameters	Enable Conditions
Battery voltage	≥ 10.9 V
Engine speed	≥ 500 rpm

### 3. GENERAL DRIVING CYCLE

Always perform the diagnosis continuously.

### 4. DIAGNOSTIC METHOD

Judge as NG when the following conditions are established.

#### Judgment Value

Malfunction Criteria	Threshold Value
Fault signal from ignition drive IC	ON

**Time Needed for Diagnosis:** 2500 ms

**Malfunction Indicator Light Illumination:** Illuminates as soon as a malfunction occurs.

## CV:DTC P0352 IGNITION COIL B PRIMARY/SECONDARY CIRCUIT

### 1. OUTLINE OF DIAGNOSIS

NOTE:

For the detection standard, refer to DTC P0351. <Ref. to GD(w/o STI)-119, DTC P0351 IGNITION COIL A PRIMARY/SECONDARY CIRCUIT, Diagnostic Trouble Code (DTC) Detecting Criteria.>

## CW:DTC P0353 IGNITION COIL C PRIMARY/SECONDARY CIRCUIT

### 1. OUTLINE OF DIAGNOSIS

NOTE:

For the detection standard, refer to DTC P0351. <Ref. to GD(w/o STI)-119, DTC P0351 IGNITION COIL A PRIMARY/SECONDARY CIRCUIT, Diagnostic Trouble Code (DTC) Detecting Criteria.>

## CX:DTC P0354 IGNITION COIL D PRIMARY/SECONDARY CIRCUIT

### 1. OUTLINE OF DIAGNOSIS

NOTE:

For the detection standard, refer to DTC P0351. <Ref. to GD(w/o STI)-119, DTC P0351 IGNITION COIL A PRIMARY/SECONDARY CIRCUIT, Diagnostic Trouble Code (DTC) Detecting Criteria.>

# Diagnostic Trouble Code (DTC) Detecting Criteria

## GENERAL DESCRIPTION

### CY:DTC P0365 CAMSHAFT POSITION SENSOR “B” CIRCUIT (BANK 1)

#### 1. OUTLINE OF DIAGNOSIS

Detect the open or short circuit of the camshaft position sensor.

When there is no camshaft position signal input continuously, judge as NG.

#### 2. COMPONENT DESCRIPTION

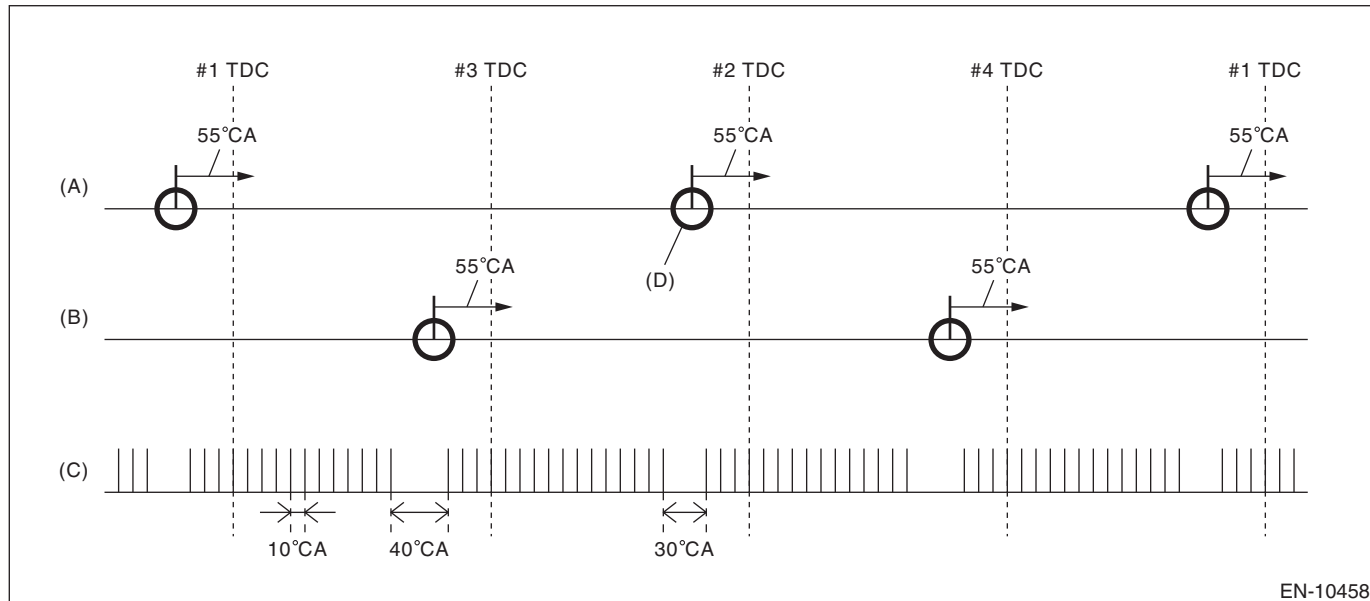

- (A) Exhaust cam signal RH
- (B) Exhaust cam signal LH
- (C) Crankshaft signal
- (D) Camshaft position signal: When normal, there will be 2 camshaft position signals for every 2 crankshaft revolutions.

#### 3. ENABLE CONDITIONS

Secondary Parameters	Enable Conditions
Battery voltage	≥ 10.9 V
Elapsed time after starting the engine	≥ 0.2 s

#### 4. GENERAL DRIVING CYCLE

Always perform the diagnosis continuously.

#### 5. DIAGNOSTIC METHOD

If the duration of time while the following conditions are met is longer than the time indicated, judge as NG.

##### Judgment Value

Malfunction Criteria	Threshold Value
Amount of camshaft sensor signal during 1.5 revs of crankshaft	= 0

**Time Needed for Diagnosis:** 6 engine revs.

**Malfunction Indicator Light Illumination:** Illuminates as soon as a malfunction occurs.

# Diagnostic Trouble Code (DTC) Detecting Criteria

GENERAL DESCRIPTION

## CZ:DTC P0366 CAMSHAFT POSITION SENSOR B CIRCUIT RANGE/PERFORMANCE (BANK 1)

### 1. OUTLINE OF DIAGNOSIS

Detect the malfunction of camshaft position sensor property.  
Judge as NG when the number of camshaft signals remains abnormal.

### 2. COMPONENT DESCRIPTION

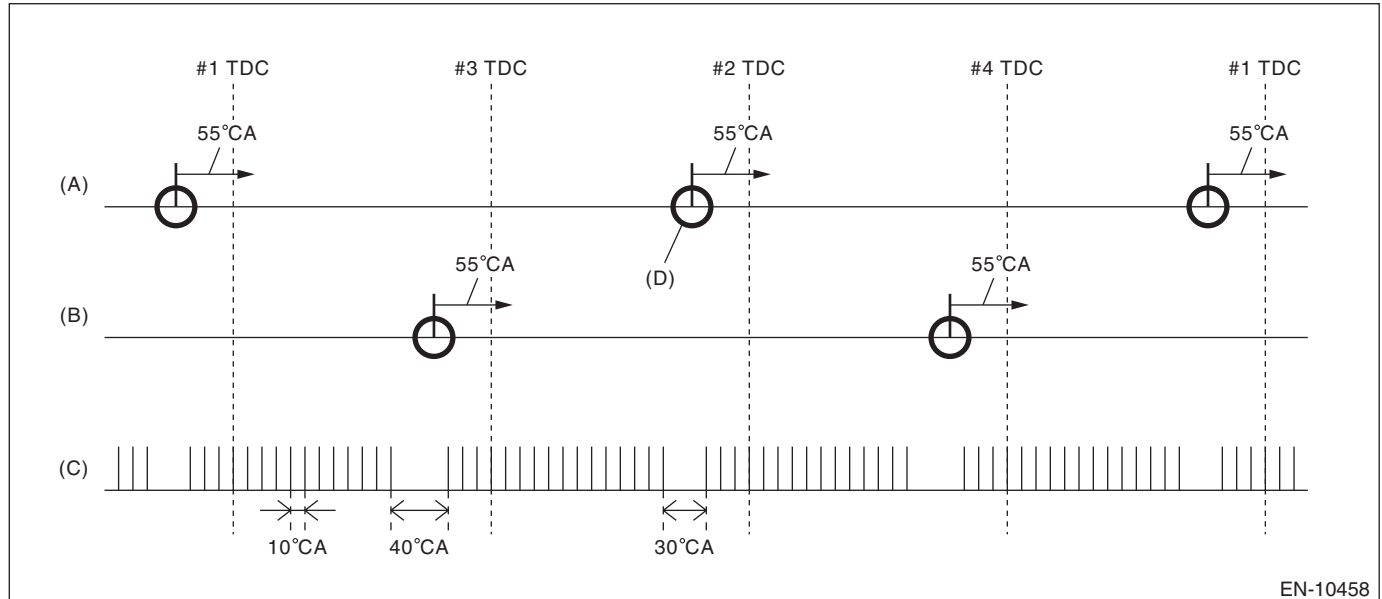

EN-10458

- (A) Exhaust cam signal RH      (B) Exhaust cam signal LH      (C) Crankshaft signal  
(D) Camshaft position signal: When normal, there will be 2 camshaft position signals for every 2 crankshaft revolutions.

### 3. ENABLE CONDITIONS

Secondary Parameters	Enable Conditions
Battery voltage	≥ 10.9 V

### 4. GENERAL DRIVING CYCLE

Always perform the diagnosis continuously.

### 5. DIAGNOSTIC METHOD

Judge as NG when the condition continues where the number of camshaft position sensor signals are not 2 times during 2 revs of crankshaft.

#### Judgment Value

Malfunction Criteria	Threshold Value
Amount of camshaft sensor signal during 2 revs of crankshaft	≠ 2 times

**Time Needed for Diagnosis:** Engine two revolutions × 4 times

**Malfunction Indicator Light Illumination:** Illuminates as soon as a malfunction occurs.

## Diagnostic Trouble Code (DTC) Detecting Criteria

### GENERAL DESCRIPTION

---

#### **DA:DTC P0390 CAMSHAFT POSITION SENSOR “B” CIRCUIT (BANK 2)**

##### **1. OUTLINE OF DIAGNOSIS**

###### **NOTE:**

For the detection standard, refer to DTC P0365. <Ref. to GD(w/o STI)-120, DTC P0365 CAMSHAFT POSITION SENSOR “B” CIRCUIT (BANK 1), Diagnostic Trouble Code (DTC) Detecting Criteria.>

#### **DB:DTC P0391 CAMSHAFT POSITION SENSOR B CIRCUIT RANGE/PERFORMANCE (BANK 2)**

##### **1. OUTLINE OF DIAGNOSIS**

###### **NOTE:**

For the detection standard, refer to DTC P0366. <Ref. to GD(w/o STI)-121, DTC P0366 CAMSHAFT POSITION SENSOR B CIRCUIT RANGE/PERFORMANCE (BANK 1), Diagnostic Trouble Code (DTC) Detecting Criteria.>



## DC:DTC P0400 EXHAUST GAS RECIRCULATION FLOW

### 1. OUTLINE OF DIAGNOSIS

Detect EGR system malfunction.

Intake manifold pressure (negative pressure) is constant because the throttle valve is fully closed during deceleration fuel cut. At this time, when the EGR control valve is opened/closed, the intake manifold pressure will change. EGR System OK/NG is judged by the range of this change.

### 2. COMPONENT DESCRIPTION

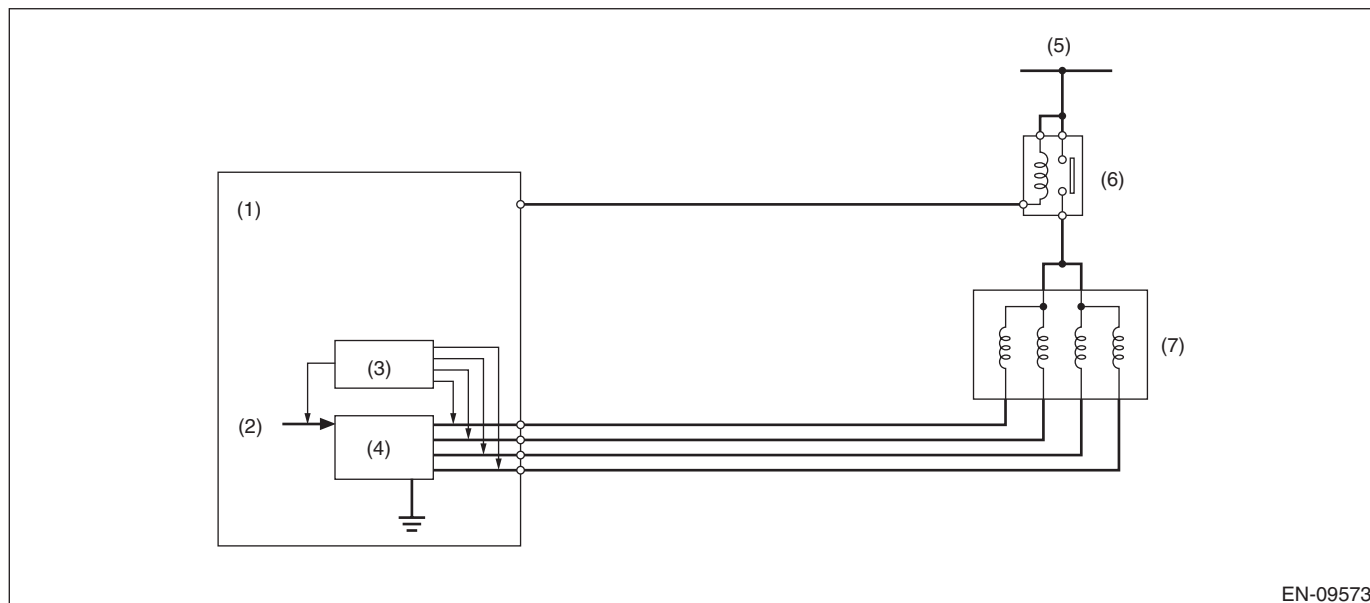

- |                                 |                       |                       |
|---------------------------------|-----------------------|-----------------------|
| (1) Engine control module (ECM) | (4) Switching circuit | (6) Main relay        |
| (2) Computer unit (CPU)         | (5) Battery voltage   | (7) EGR control valve |
| (3) Detecting circuit           |                       |                       |

### 3. ENABLE CONDITIONS

Secondary Parameters	Enable Conditions
Engine speed	1300 rpm — 5000 rpm
Ambient air temperature	≥ 5°C (41°F)
Battery voltage	≥ 10.9 V
Atmospheric pressure	≥ 75 kPa (563 mmHg, 22.2 inHg)
Vehicle speed	≥ 40 km/h (24.9 MPH)
Deceleration fuel cut of 3000 ms or more	Experienced
Neutral switch	OFF

### 4. GENERAL DRIVING CYCLE

During deceleration fuel cut from 40 km/h (24.9 MPH) or more, perform diagnosis only once. Be careful of vehicle speed and engine speed. (Diagnosis will not be completed if the vehicle speed and engine speed conditions become out of specification due to deceleration.)

# Diagnostic Trouble Code (DTC) Detecting Criteria

## GENERAL DESCRIPTION

---

### 5. DIAGNOSTIC METHOD

Measure the pressure values when the enable conditions are established, and perform diagnosis by calculating those results.

1. Label the intake manifold pressure value as PMOF1, which is observed when enable conditions are established, and set the EGR target step to 55 steps (nearly full open).
  2. Label the intake manifold pressure value as PMON, which is observed after one second has passed since EGR target step was set to 55 steps (when the enable conditions were established), and set the EGR target step to 0.
  3. Label the intake manifold pressure as PMOF2, which is observed after one second has passed since EGR target step was set to 0 (after two seconds have passed since the enable conditions were established).
- Judge as NG when the following conditions are established.

#### Judgment Value

Malfunction Criteria	Threshold Value
$PMON - (PMOF1 + PMOF2)/2$	< 2.48 kPa (18.6 mmHg, 0.7 inHg)

**Time Needed for Diagnosis:** 2 seconds

# Diagnostic Trouble Code (DTC) Detecting Criteria

GENERAL DESCRIPTION

**Malfunction Indicator Light Illumination:** Illuminates when malfunction occurs in 2 continuous driving cycles.

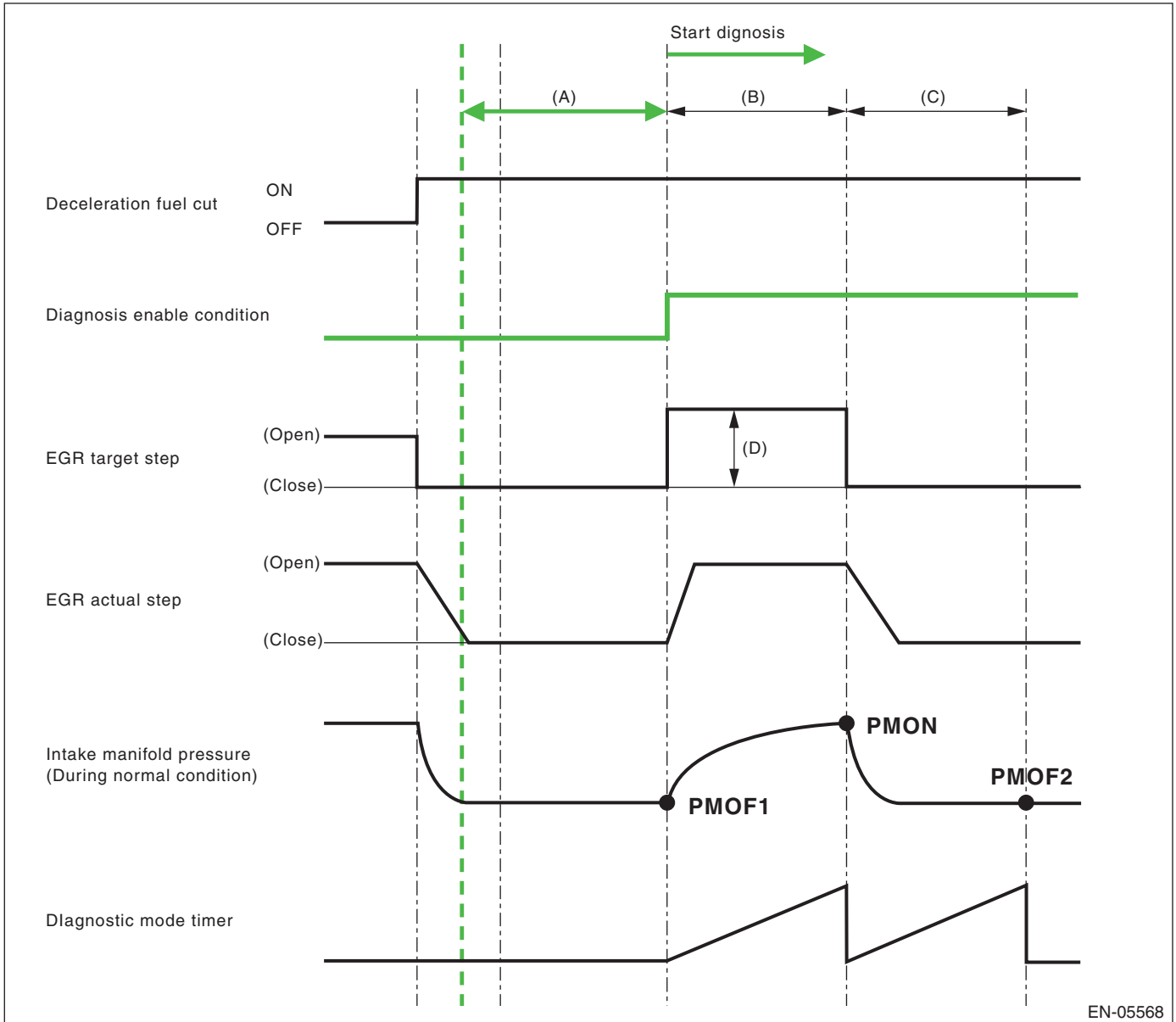

EN-05568

(A) 3000 ms

(B) 1000 ms

(C) 1000 ms

(D) 55 steps

# Diagnostic Trouble Code (DTC) Detecting Criteria

## GENERAL DESCRIPTION

### DD:DTC P0420 CATALYST SYSTEM EFFICIENCY BELOW THRESHOLD (BANK 1)

#### 1. OUTLINE OF DIAGNOSIS

Detect the deterioration of the catalyst function.

Though the rear oxygen sensor output changes slowly with a new catalyst, the sensor output with a deteriorated catalyst becomes high and the inversion time is shortened.

For this reason, the catalyst diagnosis is carried out by monitoring the rear oxygen sensor output and comparing it with the front oxygen (A/F) sensor output.

#### 2. COMPONENT DESCRIPTION

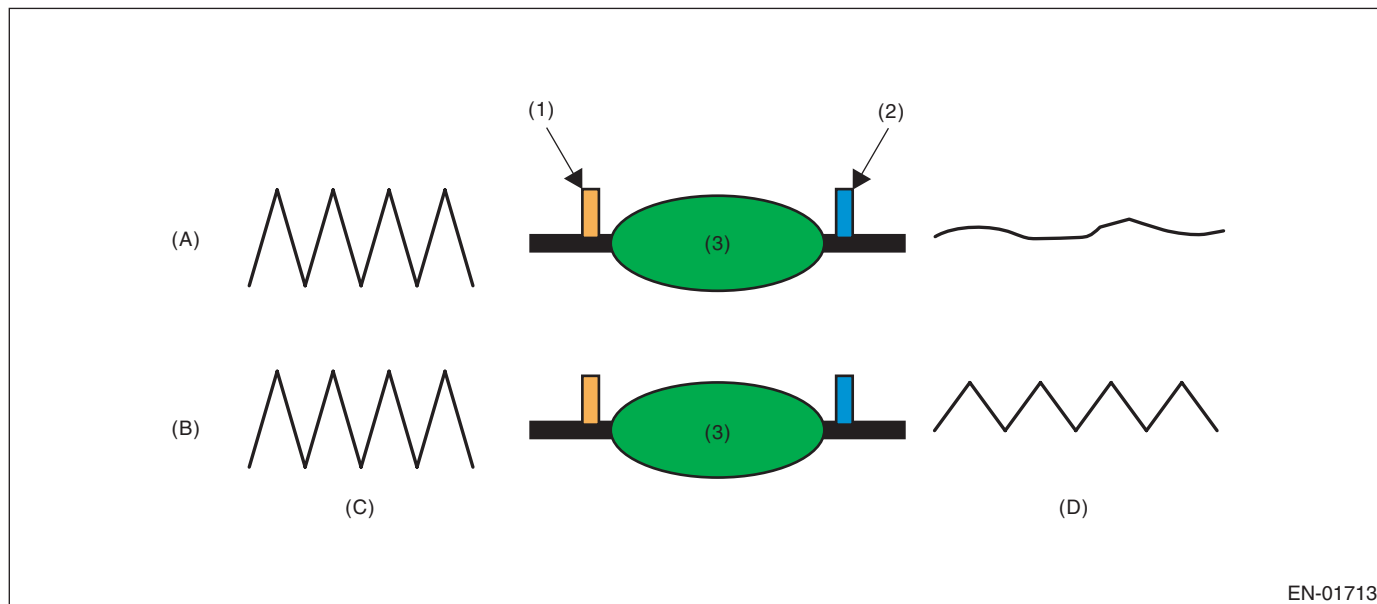

EN-01713

(A) Normal

(B) Deterioration

(C) Output waveform from the front oxygen (A/F) sensor

(D) Output waveform from the rear oxygen sensor

(1) Front oxygen (A/F) sensor

(2) Rear oxygen sensor

(3) Catalytic converter

#### 3. ENABLE CONDITIONS

Secondary Parameters	Enable Conditions
Battery voltage	≥ 10.9 V
Atmospheric pressure	≥ 75 kPa (563 mmHg, 22.2 inHg)
Estimated catalyst temperature	≥ 480°C (896°F)
Main feedback	In operation
Sub feedback	In operation
Second diagnosis of P0441	Not in operation
Vehicle speed	> 40 km/h (24.9 MPH)
Amount of intake air	≥ 5 g/s (0.18 oz/s) and < 45 g/s (1.59 oz/s)
Rear oxygen output change from 550 mV or less to 550 mV or more	Experienced after fuel cut
Estimated temperature of the rear oxygen sensor element	≥ 450°C (842°F)

#### 4. GENERAL DRIVING CYCLE

Perform the diagnosis only once at a constant 60 km/h (37.3 MPH) or higher.

# Diagnostic Trouble Code (DTC) Detecting Criteria

GENERAL DESCRIPTION

## 5. DIAGNOSTIC METHOD

After the enable conditions have been established, calculate the front oxygen (A/F) sensor lambda value deviation sum value ( $\sum |(sglmd_n - sglmd_{n-1})|$ ), and rear oxygen sensor output voltage deviation sum value ( $\sum |(ro2sad_n - ro2sad_{n-1})|$ ) in every 32 ms  $\times$  4 times. If the front oxygen (A/F) sensor lambda value deviation sum value ( $\sum |(sglmd_n - sglmd_{n-1})|$ ) is the predetermined value or more, calculate the diagnostic value.

If the duration of time while the following conditions are met is within the time indicated, judge as NG.

### Judgment Value

Malfunction Criteria	Threshold Value
$\sum  (ro2sad_n - ro2sad_{n-1})  / \sum  (sglmd_n - sglmd_{n-1}) $	> 9

**Time Needed for Diagnosis:** 30 — 55 seconds

**Malfunction Indicator Light Illumination:** Illuminates when malfunction occurs in 2 continuous driving cycles.

# Diagnostic Trouble Code (DTC) Detecting Criteria

## GENERAL DESCRIPTION

### DE:DTC P0441 EVAPORATIVE EMISSION CONT. SYS. INCORRECT PURGE FLOW

#### 1. OUTLINE OF DIAGNOSIS

Detect the malfunction of purge flow by the change of ELCM pressure sensor output value before/after purge introduction.

#### 2. ENABLE CONDITIONS

Secondary Parameters	Enable Conditions
<Common conditions>	
Battery voltage	≥ 10.9 V
Atmospheric pressure	≥ 75 kPa (563 mmHg, 22.2 inHg)
<First diagnosis>	
Total time of canister purge operation	≥ 120 s
<Second diagnosis>	
1st Stage monitor judgment	Fail
Vehicle speed	≥ 30 km/h (18.6 MPH)
Main feedback	In operation
Estimated ambient temperature value	≥ -25°C (-13°F)

#### 3. GENERAL DRIVING CYCLE

Perform the diagnosis only once after engine start.

#### 4. DIAGNOSTIC METHOD

##### First diagnosis

Pressure decreases when the purge is introduced compared with when the purge is not performed. By using this, judge if the purge is correctly performed. If there is no pressure decrease, go to the second diagnosis.

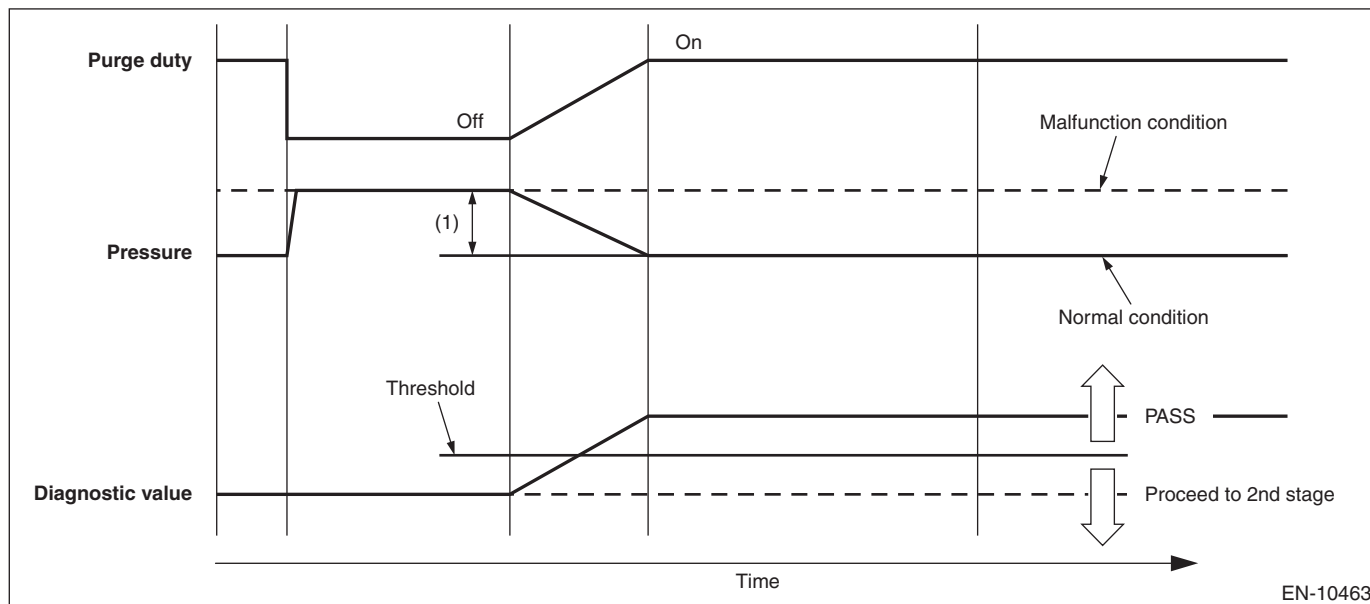

(1) 75 Pa (0.6 mmHg, 0.02 inHg)

Judge as NG when the following conditions are established.

##### Judgment Value

Malfunction Criteria	Threshold Value
ELCM pressure value when purge is not performed – ELCM pressure value when purge is performed	< 80 Pa (0.6 mmHg, 0.02 inHg)

# Diagnostic Trouble Code (DTC) Detecting Criteria

GENERAL DESCRIPTION

**Time Needed for Diagnosis:** 8 — 38 seconds

**Second diagnosis**

Close the ELCM switching valve, and close the fuel tank completely, and perform the forced purging. If pressure change amount is 667 Pa (5 mmHg, 0.2 inHg) or less, judge as malfunction of purge flow.

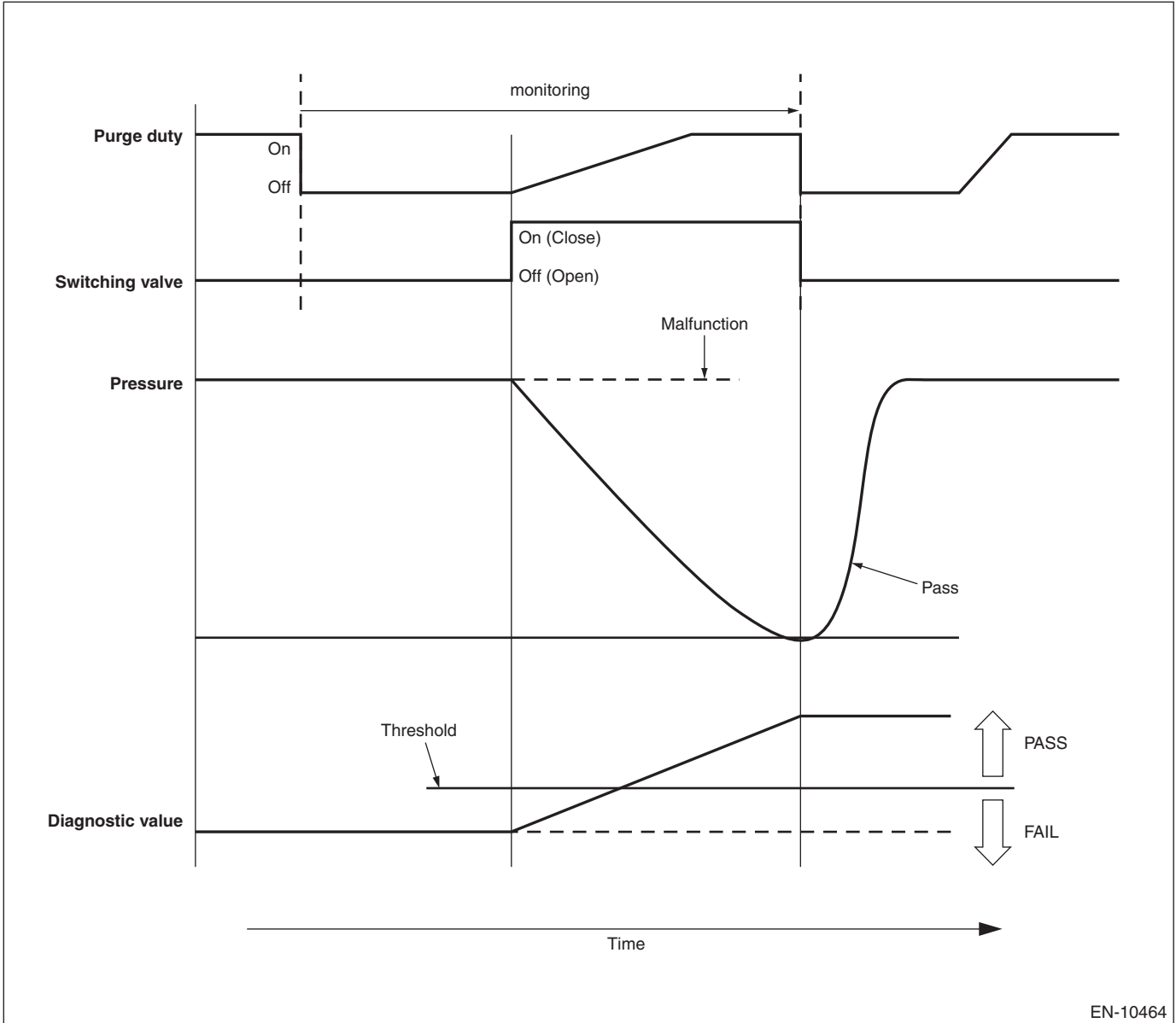

EN-10464

Judge as NG when the following conditions are established.

**Judgment Value**

Malfunction Criteria	Threshold Value
ELCM pressure value when purge is not performed – ELCM pressure value when purge is performed	< 667 Pa (5 mmHg, 0.2 inHg)

**Time Needed for Diagnosis:** 21 seconds

**Malfunction Indicator Light Illumination:** Illuminates when malfunction occurs in 2 continuous driving cycles.

# Diagnostic Trouble Code (DTC) Detecting Criteria

## GENERAL DESCRIPTION

### DF:DTC P0451 EVAPORATIVE EMISSION SYSTEM PRESSURE SENSOR/ SWITCH RANGE/PERFORMANCE

#### 1. OUTLINE OF DIAGNOSIS

Detect the malfunction of ELCM pressure sensor output properties.

Judge as NG when the ELCM pressure sensor output value is largely different from the intake manifold pressure when the ignition switch is ON.

#### 2. COMPONENT DESCRIPTION

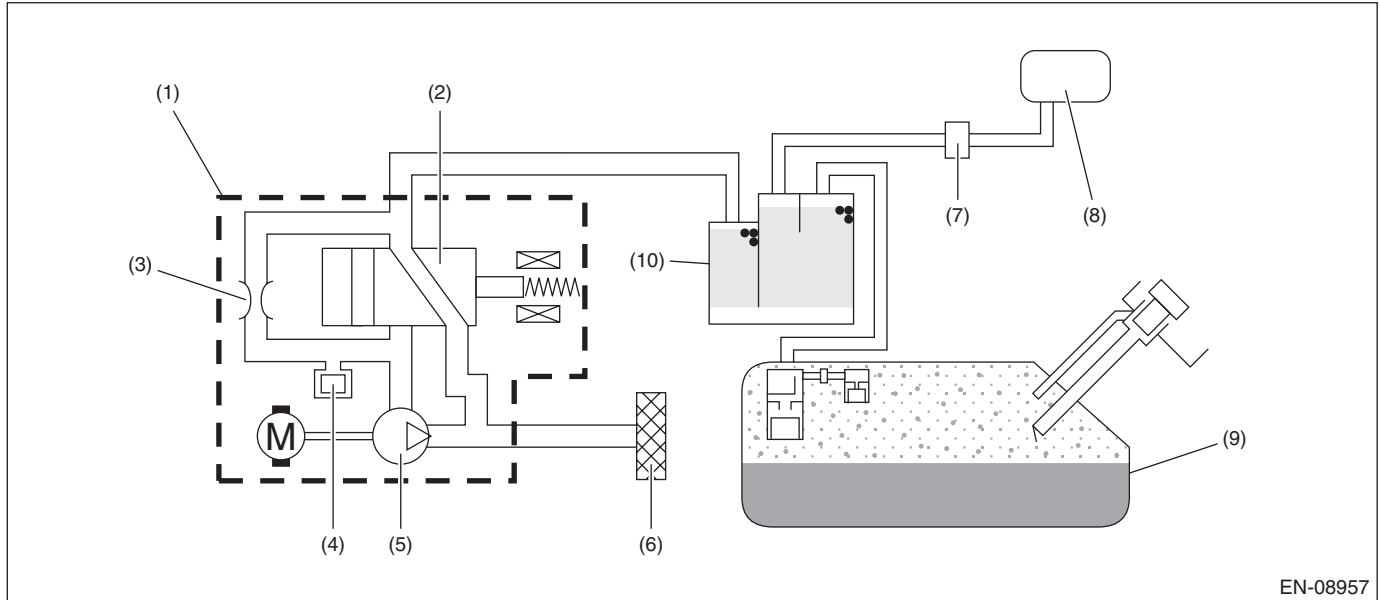

EN-08957

- |   |                                  |               |
|---|----------------------------------|---------------|
| (1) ELCM                                  | (5) Vacuum pump                  | (9) Fuel tank |
| (2) Switching valve                       | (6) Drain filter                 | (10) Canister |
| (3) Reference orifice (0.02 inch orifice) | (7) Purge control solenoid valve |               |
| (4) Pressure sensor                       | (8) Intake manifold              |               |

#### 3. ENABLE CONDITIONS

Secondary Parameters	Enable Conditions
Elapsed time after ignition switch is turned to ON	$\geq 0.5$ s and $< 60$ s
Soaking time	$\geq 60$ s
ELCM vacuum pump	Not in operation
ELCM switching valve	Open
Purge control	Not in operation

#### 4. GENERAL DRIVING CYCLE

Perform the diagnosis once at ignition ON.



# Diagnostic Trouble Code (DTC) Detecting Criteria

GENERAL DESCRIPTION

## 5. DIAGNOSTIC METHOD

If the duration of time while the following conditions are met is longer than the time indicated, judge as NG.

### Judgment Value

Malfunction Criteria	Threshold Value
ELCM pressure sensor output value when ignition switch is ON – intake manifold pressure (absolute pressure) when ignition switch is ON	> 12.4 kPa (93 mmHg, 3.7 inHg)

**Time Needed for Diagnosis:** 0.32 seconds

**Malfunction Indicator Light Illumination:** Illuminates when malfunction occurs in 2 continuous driving cycles.

# Diagnostic Trouble Code (DTC) Detecting Criteria

## GENERAL DESCRIPTION

### DG:DTC P0452 EVAPORATIVE EMISSION SYSTEM PRESSURE SENSOR/ SWITCH LOW

#### 1. OUTLINE OF DIAGNOSIS

Detect the open or short circuit of the ELCM pressure sensor.  
Judge as NG if out of specification.

#### 2. COMPONENT DESCRIPTION

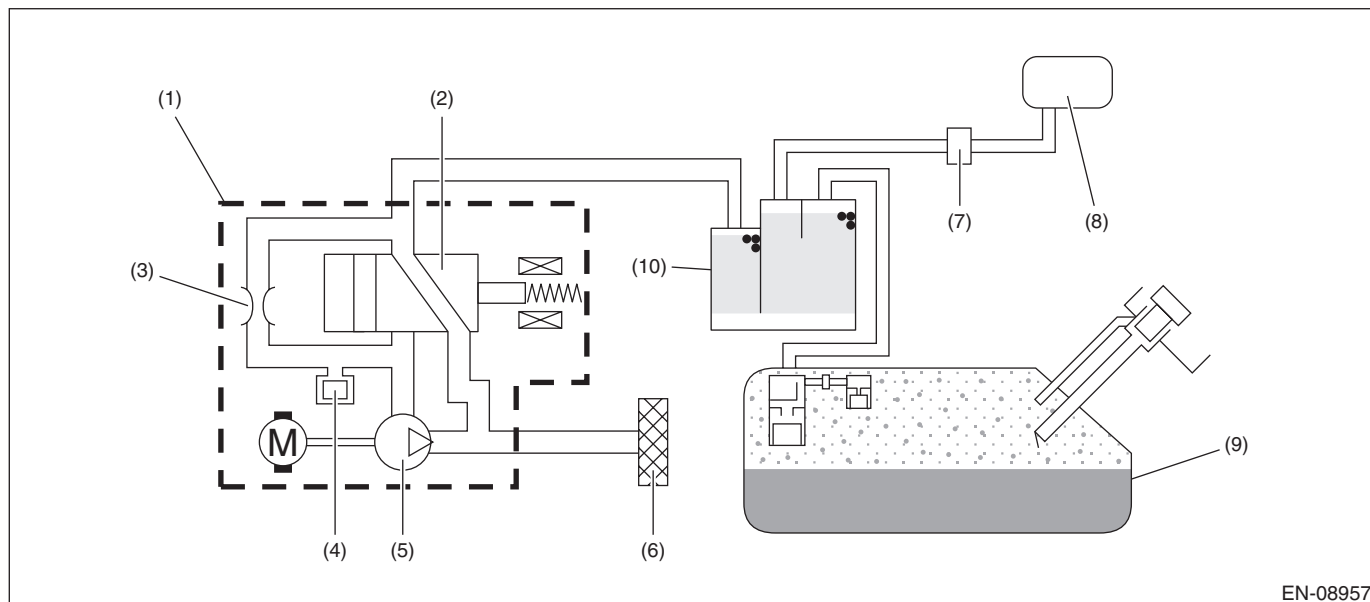

- |   |                                  |               |
|---|----------------------------------|---------------|
| (1) ELCM                                  | (5) Vacuum pump                  | (9) Fuel tank |
| (2) Switching valve                       | (6) Drain filter                 | (10) Canister |
| (3) Reference orifice (0.02 inch orifice) | (7) Purge control solenoid valve |               |
| (4) Pressure sensor                       | (8) Intake manifold              |               |

#### 3. ENABLE CONDITIONS

Secondary Parameters	Enable Conditions
Battery voltage	$\geq 10.9 \text{ V}$

#### 4. GENERAL DRIVING CYCLE

Always perform the diagnosis continuously.

#### 5. DIAGNOSTIC METHOD

If the duration of time while the following conditions are met is longer than the time indicated, judge as NG.

##### Judgment Value

Malfunction Criteria	Threshold Value
Output voltage	$< 0.92 \text{ V}$

**Time Needed for Diagnosis:** 1000 ms

**Malfunction Indicator Light Illumination:** Illuminates as soon as a malfunction occurs.

# Diagnostic Trouble Code (DTC) Detecting Criteria

GENERAL DESCRIPTION

## DH:DTC P0453 EVAPORATIVE EMISSION SYSTEM PRESSURE SENSOR/ SWITCH HIGH

### 1. OUTLINE OF DIAGNOSIS

Detect the open or short circuit of the ELCM pressure sensor.

Judge as NG if out of specification.

### 2. COMPONENT DESCRIPTION

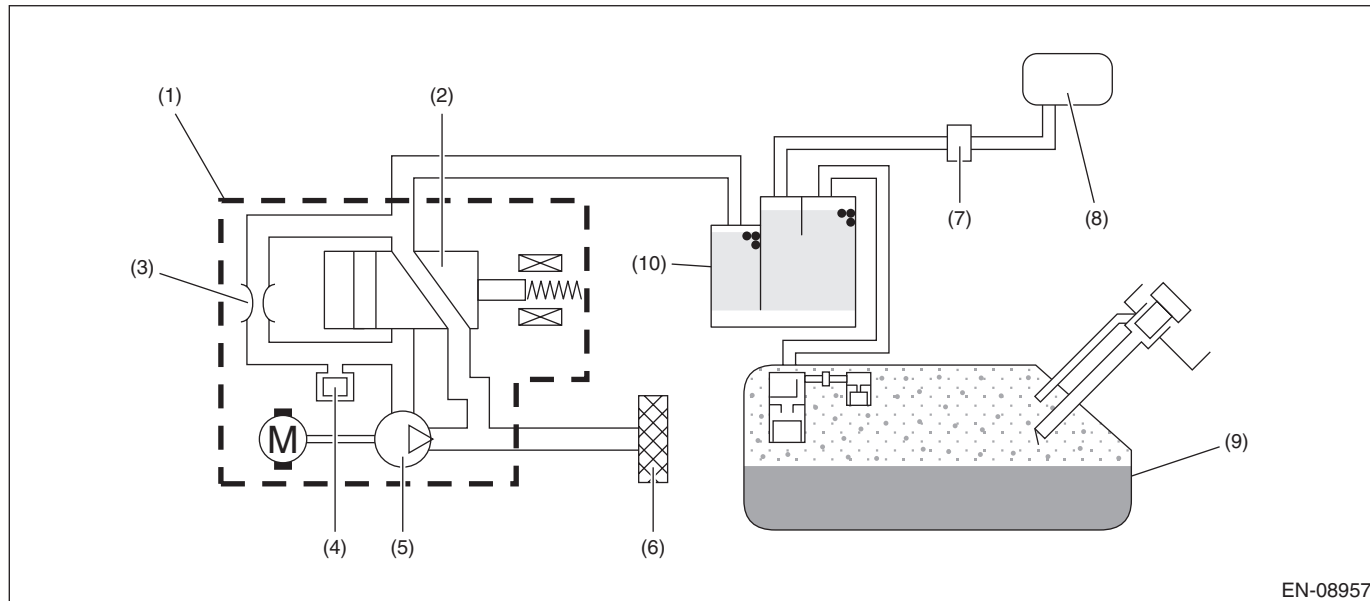

- |   |                                  |               |
|---|----------------------------------|---------------|
| (1) ELCM                                  | (5) Vacuum pump                  | (9) Fuel tank |
| (2) Switching valve                       | (6) Drain filter                 | (10) Canister |
| (3) Reference orifice (0.02 inch orifice) | (7) Purge control solenoid valve |               |
| (4) Pressure sensor                       | (8) Intake manifold              |               |

### 3. ENABLE CONDITIONS

Secondary Parameters	Enable Conditions
Battery voltage	$\geq 10.9 \text{ V}$

### 4. GENERAL DRIVING CYCLE

Always perform the diagnosis continuously.

### 5. DIAGNOSTIC METHOD

If the duration of time while the following conditions are met is longer than the time indicated, judge as NG.

#### Judgment Value

Malfunction Criteria	Threshold Value
Output voltage	$> 4.25 \text{ V}$

**Time Needed for Diagnosis:** 1000 ms

**Malfunction Indicator Light Illumination:** Illuminates as soon as a malfunction occurs.

# Diagnostic Trouble Code (DTC) Detecting Criteria

## GENERAL DESCRIPTION

### DI: DTC P0455 EVAPORATIVE EMISSION SYSTEM LEAK DETECTED (LARGE LEAK)

#### 1. OUTLINE OF DIAGNOSIS

This diagnosis judges whether the ELCM operation is normal or not, and whether the evaporative emission system has leak and clogging or not.

To purge the canister, after driving, perform the five hours soaking after ignition switch OFF in order to stabilize the evaporative gas status. \* After 5, 7 or 9.5 hours passed, ECM is activated by soaking timer, and the leak check is started.

Judges whether the ELCM operation is normal or not, by measuring the reference pressure status via reference orifice (0.02 inch orifice). Judge as malfunction if the reference pressure is out of specified range. Then, judge whether there is a leak or not, by comparing the pressure (leak pressure) when the reference pressure and the evaporative emission system are in negative pressure condition. Judge as system leak in the evaporative emission system if the leak pressure is higher than reference pressure. Judge as clogging of pipe if the leak pressure becomes lower than the reference pressure within the specified amount of time.

0.02 inch leak and 0.04 inch leak can be distinguished by measuring the leak pressure.

The diagnosis results are stored inside ECM until the engine is started again.

\*: When the test conditions are not met in 5 hours, perform diagnosis at elapsed time of 7 hours. When the test conditions are not met in 7 hours, perform diagnosis at elapsed time of 9.5 hours.

Diagnostic item	
ELCM system (ELCM body)	Vacuum pump stuck Switching valve stuck to open Switching valve stuck to close Reference orifice flow large Reference orifice flow small
Leak check	Large leak <ul style="list-style-type: none"> <li>• 0.04 inch leak</li> <li>• Fuel cap loose</li> <li>• Fuel cap off</li> <li>• System malfunction</li> </ul>
	Very small leak <ul style="list-style-type: none"> <li>• 0.02 inch leak</li> </ul>
Clogging of pipe	—

#### OUTLINE OF DIAGNOSIS

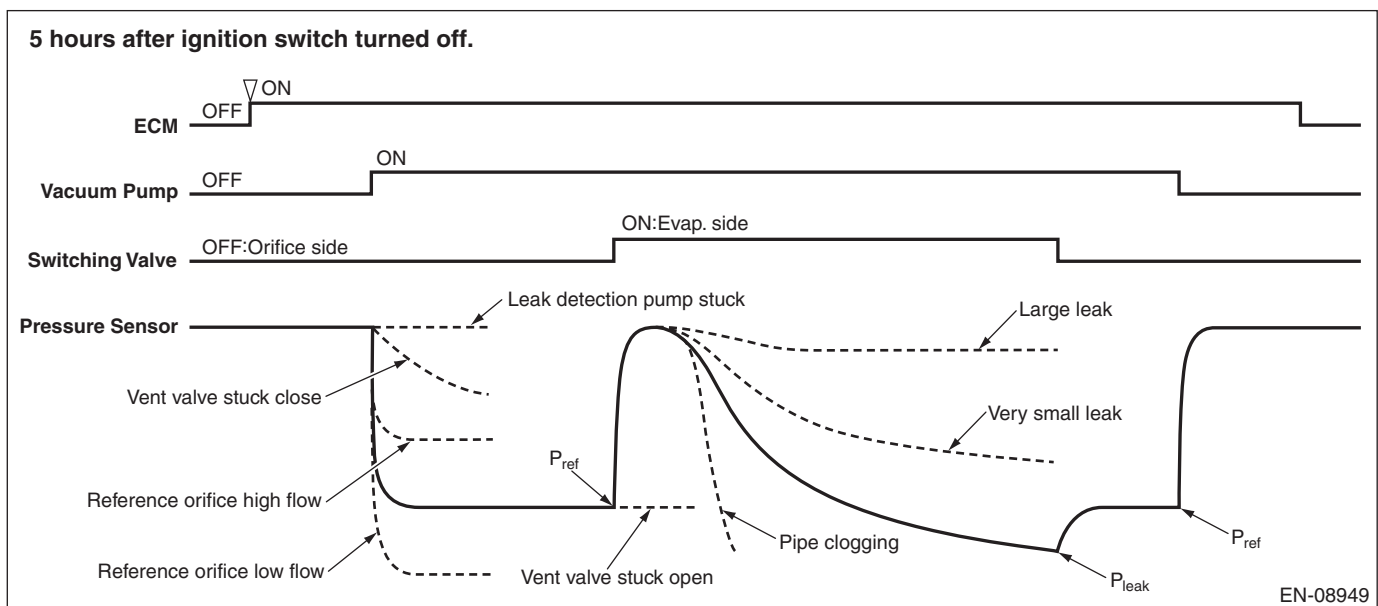

# Diagnostic Trouble Code (DTC) Detecting Criteria

GENERAL DESCRIPTION

## 2. COMPONENT DESCRIPTION

ELCM consists of the pressure sensor, the reference orifice (diameter of 0.02 inch), the vacuum pump which introduces the negative pressure into evaporative emission system, and the switching valve which switches the passage to introduce the negative pressure.

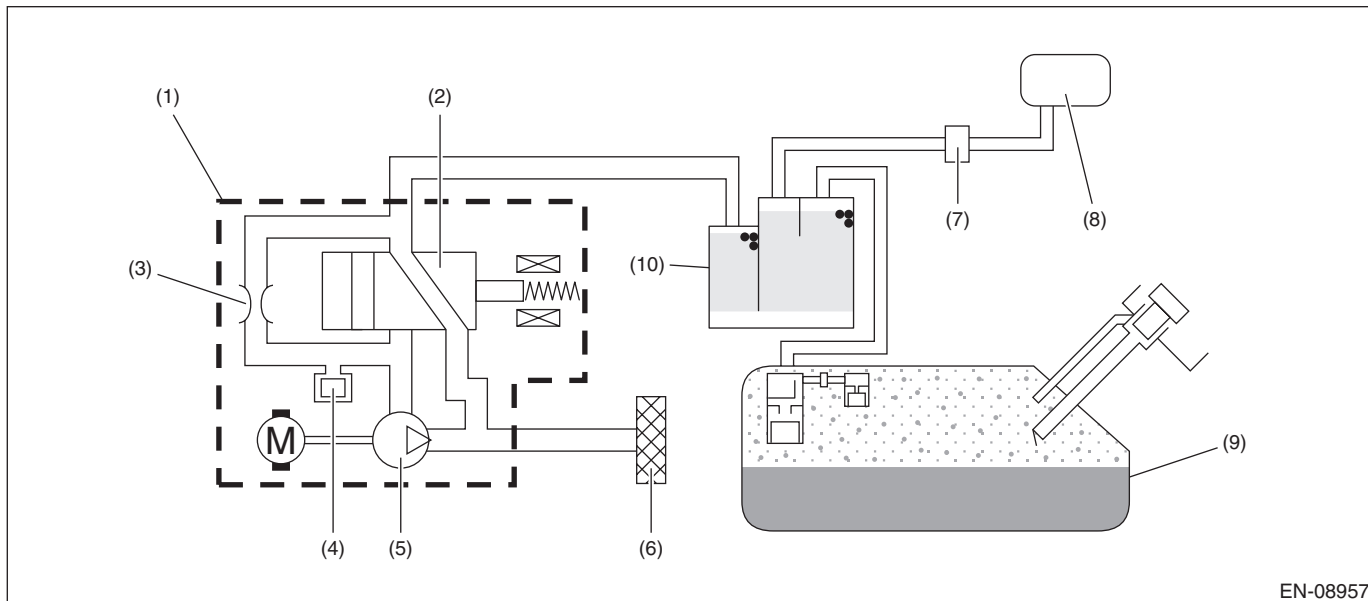

EN-08957

- |   |                                  |               |
|---|----------------------------------|---------------|
| (1) ELCM                                  | (5) Vacuum pump                  | (9) Fuel tank |
| (2) Switching valve                       | (6) Drain filter                 | (10) Canister |
| (3) Reference orifice (0.02 inch orifice) | (7) Purge control solenoid valve |               |
| (4) Pressure sensor                       | (8) Intake manifold              |               |

## 3. ENABLE CONDITIONS

Secondary Parameters	Enable Conditions
Activation of soaking timer	Completed
Battery voltage	≥ 10.9 V
Engine coolant temperature	≥ 4.4°C (39.9°F) and < 45°C (113°F)
Atmospheric pressure	≥ 75 kPa (563 mmHg, 22.2 inHg)
Accumulated purge amount during previous driving cycle	≥ Value of Map 1

### Map 1

Engine coolant temperature °C (°F)	0 (32)	30 (86)	35 (95)	40 (104)	45 (113)
Accumulated purge amount during previous driving cycle g (oz)	3000 (105.81)	3000 (105.81)	8000 (282.16)	13000 (458.51)	18000 (634.86)

## 4. GENERAL DRIVING CYCLE

Perform the diagnosis only once when 5, 7 or 9.5 hours has passed after ignition switch is OFF. For more detail, refer to "OUTLINE OF DIAGNOSIS". <Ref. to GD(w/o STI)-134, OUTLINE OF DIAGNOSIS, DTC P0455 EVAPORATIVE EMISSION SYSTEM LEAK DETECTED (LARGE LEAK), Diagnostic Trouble Code (DTC) Detecting Criteria.>

# Diagnostic Trouble Code (DTC) Detecting Criteria

## GENERAL DESCRIPTION

### 5. DIAGNOSTIC METHOD

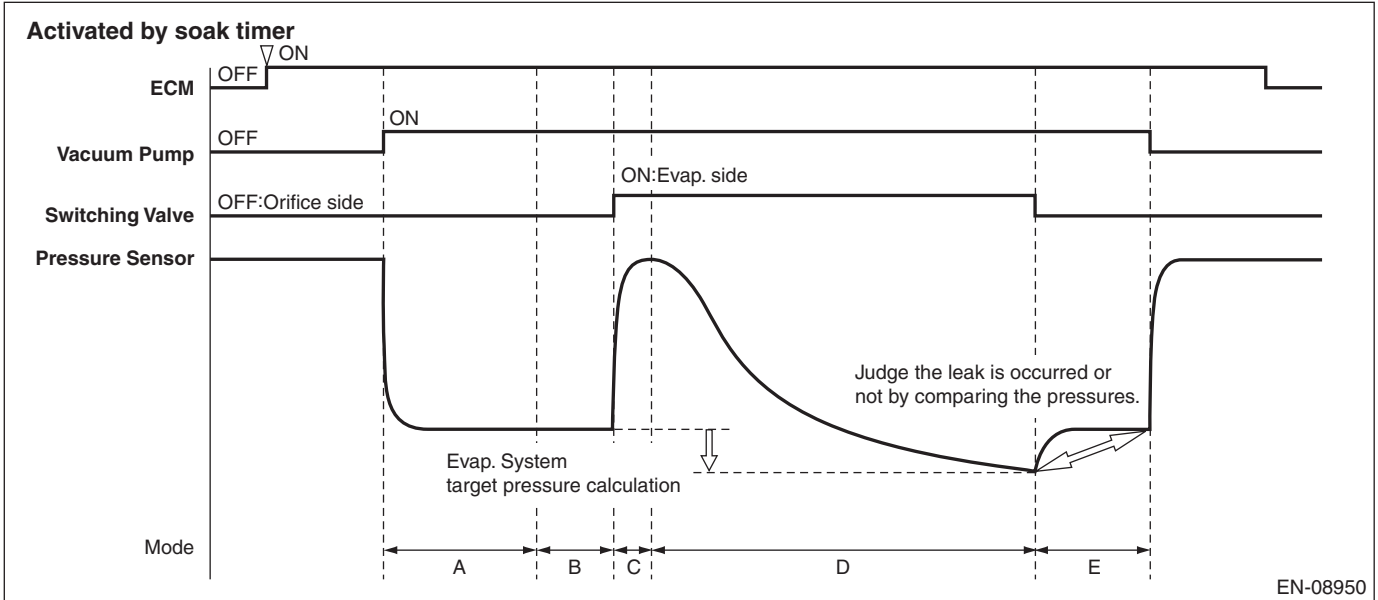

Mode	Explanation of Mode	Diagnosis Period
A	Vacuum pump operation confirmation and characteristics stability	7 s or less & 300 s
B	Measurement of reference pressure for setting the target negative pressure	40 s or less
C	Switching valve operation confirmation	12 s or less
D	Clogging of pipe diagnosis and leak pressure measurement	900 s or less
E	Reference pressure measurement for judgment	40 s or less

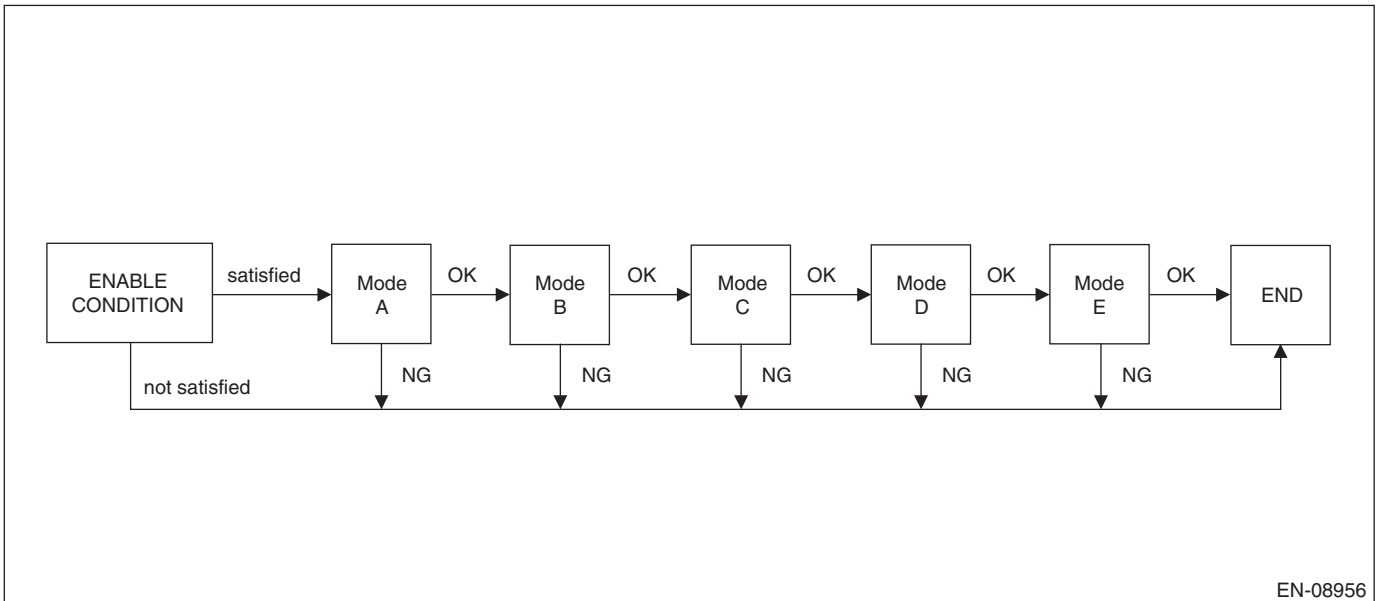

# Diagnostic Trouble Code (DTC) Detecting Criteria

GENERAL DESCRIPTION

## Mode A (Vacuum pump operation confirmation and characteristics stability)

Purpose: Detect the vacuum pump operation trouble.

Judge as NG when the following conditions are established.

Judge as OK if the following conditions are not established, and warm up for five minutes to stabilize the vacuum pump characteristics.

### Judgment Value

Malfunction Criteria	Threshold Value	DTC
Pressure sensor output value	> -224 Pa (-1.7 mmHg, -0.1 inHg)	P2404

## Mode B (Measurement of reference pressure for setting the target negative pressure)

1. Purpose: Judge the reference pressure stability.

Judge as NG when the following conditions are established.

### Judgment Value

Malfunction Criteria	Threshold Value	DTC
Pressure sensor maximum output value – Pressure sensor minimum output value	> 493 Pa (3.7 mmHg, 0.1 inHg)	P2404

2. Purpose: Judge whether the reference pressure is within the normal range, and detect the vacuum pump and orifice malfunctions.

Judge as NG when the following conditions are established.

### Judgment Value

Malfunction Criteria	Threshold Value	DTC
Reference pressure for setting the target negative pressure	< Value of Map 2 or > Value of Map 3	P2404

## Map 2

Atmospheric pressure kPa (mmHg, inHg)	70 (525, 20.7)	80 (600, 23.6)	90 (675, 26.6)	100 (750, 29.5)
Reference pressure for setting the target negative pressure Pa (mmHg, inHg)	-3972 (-29.8, -1.2)	-4079 (-30.6, -1.2)	-4186 (-31.4, -1.2)	-4292 (-32.2, -1.3)

## Map 3

Atmospheric pressure kPa (mmHg, inHg)	70 (525, 20.7)	80 (600, 23.6)	90 (675, 26.6)	100 (750, 29.5)
Reference pressure for setting the target negative pressure Pa (mmHg, inHg)	-942 (-7.1, -0.3)	-1048 (-7.9, -0.3)	-1155 (-8.7, -0.3)	-1262 (-9.5, -0.4)

## Mode C (Switching valve operation confirmation)

Purpose: Measure the pressure increase when switching valve is changed from open to close, and detect the stuck to open/close malfunctions of the switching valve.

Judge as NG when the following conditions are established.

### Judgment Value

Malfunction Criteria	Threshold Value	DTC
Pressure sensor output value – Reference pressure for setting the target negative pressure	< 224 Pa (1.7 mmHg, 0.1 inHg)	P2404

# Diagnostic Trouble Code (DTC) Detecting Criteria

## GENERAL DESCRIPTION

### Mode D (Clogging of pipe diagnosis and leak pressure measurement)

#### 1. Clogging of pipe

Purpose: Measure the time required for the evaporative emission system to reach the target negative pressure by the vacuum pump, and detect the clogging of pipe trouble.

Judge as clogging of pipe malfunction if the evaporative emission system reaches to the target negative pressure within the specified time.

#### Judgment Value

Malfunction Criteria	Threshold Value	DTC
Time required to reach to the target negative pressure When any one of the followings is established: • Reference pressure for setting the target negative pressure – Pressure sensor output value • Pressure sensor output value	$\leq 30$ s  > Value of Map 4  $< -5$ kPa ( $-37.298$ mmHg, $-1.5$ inHg)	P1451

#### Map 4

Time of negative pressure introduction ms	0	100000	200000	300000	400000	500000	600000	700000	800000	900000	1000000	1100000	1200000
Reference pressure for setting the target negative pressure – Pressure sensor output value kPa (mmHg, inHg)	0.9 (7.058, 0.3)	0.9 (7.058, 0.3)	0.9 (7.058, 0.3)	0.9 (7.058, 0.3)	0.9 (7.058, 0.3)	0.9 (7.058, 0.3)	0.9 (7.058, 0.3)	0.9 (7.058, 0.3)	0.9 (7.058, 0.3)	0.9 (7.058, 0.3)	0.9 (7.058, 0.3)	0.9 (7.058, 0.3)	0.9 (7.058, 0.3)



# Diagnostic Trouble Code (DTC) Detecting Criteria

GENERAL DESCRIPTION

## 2. Leak pressure measurement

Purpose: Measure the pressure (leak pressure) when the evaporative emission system becomes the negative pressure by the vacuum pump.

Store the pressure as a leak pressure while the following conditions are met.

### Judgment Value

Conditions for storing the leak pressure	Threshold Value
When any one of the followings is established: <ul style="list-style-type: none"><li>• Reference pressure for setting the target negative pressure – Pressure sensor output value</li><li>• Pressure sensor output value</li><li>• Time of negative pressure introduction</li></ul>	$\geq$ Value of Map 4  $< -5$ kPa ( $-37.298$ mmHg, $-1.5$ inHg) $\geq 900000$ ms

## Mode E (Measurement of reference pressure for judgment)

1. Purpose: Judge the reference pressure stability.

Judge as NG when the following conditions are established.

### Judgment Value

Malfunction Criteria	Threshold Value	DTC
Pressure sensor maximum output value – Pressure sensor minimum output value	$> 493$ Pa (3.7 mmHg, 0.1 inHg)	P2404

2. Purpose: Judge whether the reference pressure is within the normal range, and detect the vacuum pump and orifice malfunctions. Judge the vacuum pump performance stability.

Judge as NG when the following conditions are established.

### Judgment Value

Malfunction Criteria	Threshold Value	DTC
Reference pressure for judgment	$<$ Value of Map 2 or $>$ Value of Map 3	P2404

3. Purpose: Judge the presence of evaporative emission system leak.

Judge as NG when the following conditions are established.

### Judgment Value

Malfunction Criteria	Threshold Value	DTC
$<$ Large leak (0.04 inch) Leak pressure	$\geq$ lleakjdg (Pa)	P0455
lleakjdg = (Reference pressure for judgment) $\times$ 0.377 – ( $-45.5$ )		
$<$ Very small leak (0.02 inch) Leak pressure	$<$ lleakjdg (Pa)	P0456

**Time Needed for Diagnosis:** 23 min

At next engine start, confirm whether the enable conditions are satisfied even though refueling has been done during soaking, and determine the malfunction.

**Malfunction Indicator Light Illumination:** Illuminates when malfunction occurs in 2 continuous driving cycles.

## DJ:DTC P0456 EVAPORATIVE EMISSION CONTROL SYSTEM LEAK DETECTED (VERY SMALL LEAK)

### 1. OUTLINE OF DIAGNOSIS

NOTE:

For the detection standard, refer to DTC P0455.  $<$ Ref. to GD(w/o STI)-134, DTC P0455 EVAPORATIVE EMISSION SYSTEM LEAK DETECTED (LARGE LEAK), Diagnostic Trouble Code (DTC) Detecting Criteria. $>$

# Diagnostic Trouble Code (DTC) Detecting Criteria

## GENERAL DESCRIPTION

### DK:DTC P0458 EVAPORATIVE EMISSION SYSTEM PURGE CONTROL VALVE CIRCUIT LOW

#### 1. OUTLINE OF DIAGNOSIS

Detect open or short circuit of the purge control solenoid valve.

Judge as NG when the ECM output level differs from the actual terminal level.

#### 2. COMPONENT DESCRIPTION

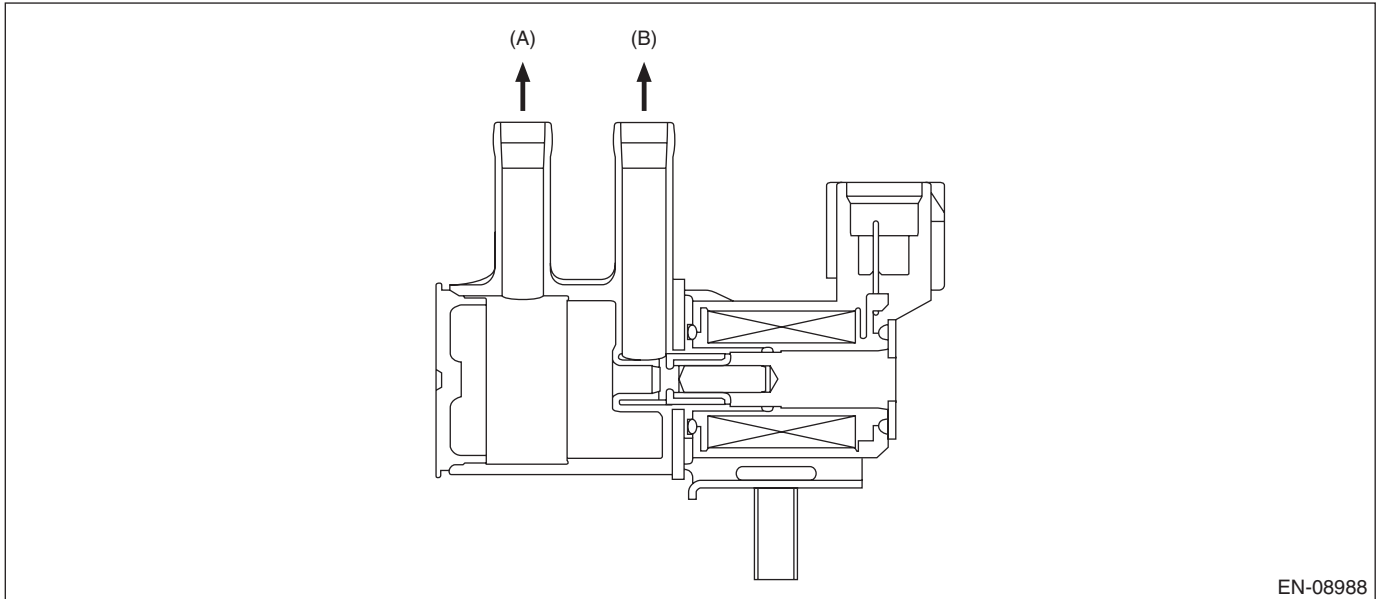

(A) To canister

(B) To intake manifold

#### 3. ENABLE CONDITIONS

Secondary Parameters	Enable Conditions
Battery voltage	$\geq 10.9 \text{ V}$
Purge control solenoid valve control duty	$\leq 80\%$

#### 4. GENERAL DRIVING CYCLE

Always perform the diagnosis after starting the engine.

#### 5. DIAGNOSTIC METHOD

If the duration of time while the following conditions are met is longer than the time indicated, judge as NG.

##### Judgment Value

Malfunction Criteria	Threshold Value
Output voltage	$\leq 2.2 \text{ V}$

**Time Needed for Diagnosis:** 2500 ms

**Malfunction Indicator Light Illumination:** Illuminates when malfunction occurs in 2 continuous driving cycles.

# Diagnostic Trouble Code (DTC) Detecting Criteria

GENERAL DESCRIPTION

## DL:DTC P0459 EVAPORATIVE EMISSION SYSTEM PURGE CONTROL VALVE CIRCUIT HIGH

### 1. OUTLINE OF DIAGNOSIS

Detect open or short circuit of the purge control solenoid valve.

Judge as NG when the ECM output level differs from the actual terminal level.

### 2. COMPONENT DESCRIPTION

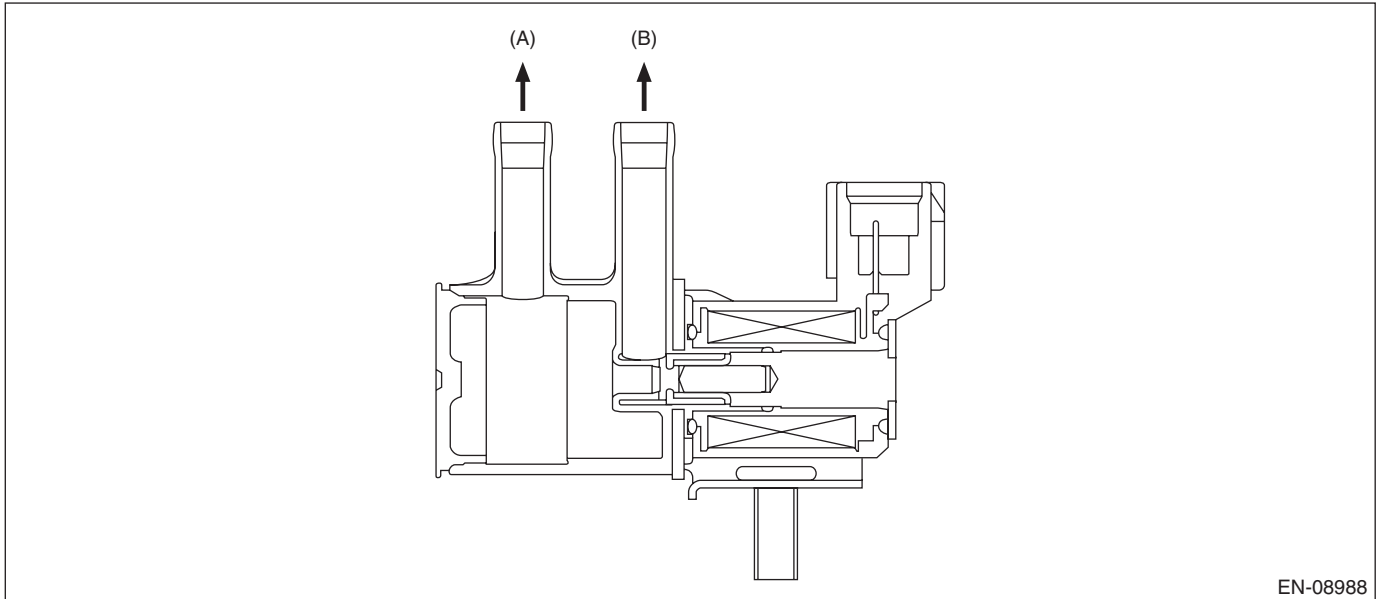

(A) To canister

(B) To intake manifold

### 3. ENABLE CONDITIONS

Secondary Parameters	Enable Conditions
Battery voltage	$\geq 10.9 \text{ V}$
Purge control solenoid valve control duty	$\geq 20\%$

### 4. GENERAL DRIVING CYCLE

Always perform the diagnosis after starting the engine.

### 5. DIAGNOSTIC METHOD

If the duration of time while the following conditions are met is longer than the time indicated, judge as NG.

#### Judgment Value

Malfunction Criteria	Threshold Value
Output current	$\geq 5 \text{ A}$

**Time Needed for Diagnosis:** 2250 ms

**Malfunction Indicator Light Illumination:** Illuminates when malfunction occurs in 2 continuous driving cycles.

# Diagnostic Trouble Code (DTC) Detecting Criteria

## GENERAL DESCRIPTION

### DM:DTC P0461 FUEL LEVEL SENSOR "A" CIRCUIT RANGE/PERFORMANCE

#### 1. OUTLINE OF DIAGNOSIS

Detect malfunctions of the fuel level sensor output property.

If the fuel level does not vary in a particular driving condition / engine condition where it should, judge as NG.

#### 2. COMPONENT DESCRIPTION

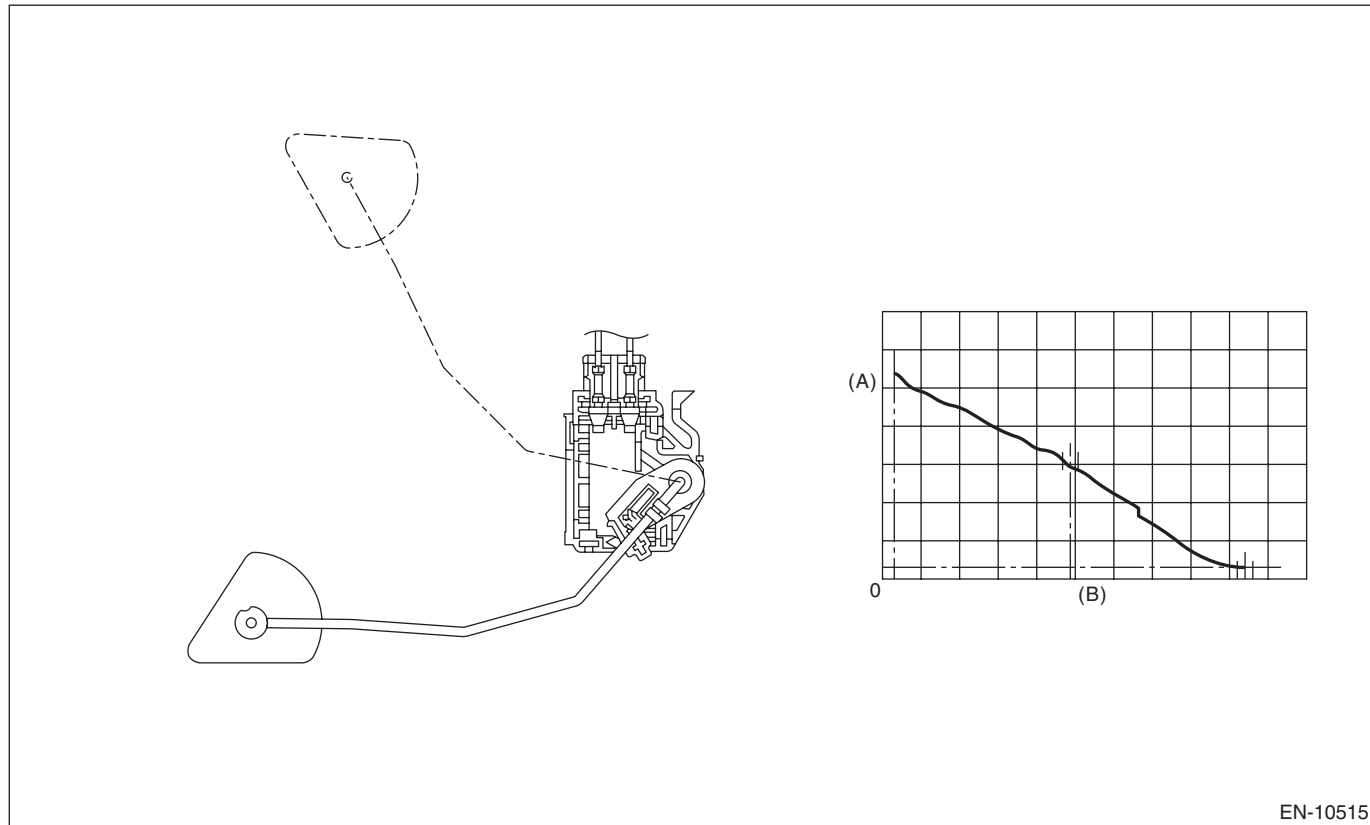

EN-10515

(A) Fuel level

(B) Resistance

#### 3. ENABLE CONDITIONS

Secondary Parameters	Enable Conditions
Elapsed time after engine starting	$\geq 5$ s
Battery voltage	$\geq 10.9$ V
Fuel injection time sum value	$\geq 2296.4$ s

#### 4. GENERAL DRIVING CYCLE

Always perform the diagnosis continuously.

#### 5. DIAGNOSTIC METHOD

Judge as NG when the following conditions are established.

##### Judgment Value

Malfunction Criteria	Threshold Value
Max. value – min. value of fuel level	$< 3.646\%$

**Time Needed for Diagnosis:** Less than 1 second

**Malfunction Indicator Light Illumination:** Illuminates when malfunction occurs in 2 continuous driving cycles.

# Diagnostic Trouble Code (DTC) Detecting Criteria

GENERAL DESCRIPTION

## DN:DTC P0462 FUEL LEVEL SENSOR “A” CIRCUIT LOW

### 1. OUTLINE OF DIAGNOSIS

Detect the open or short circuit of fuel level sensor. Judge as NG if out of specification.

### 2. COMPONENT DESCRIPTION

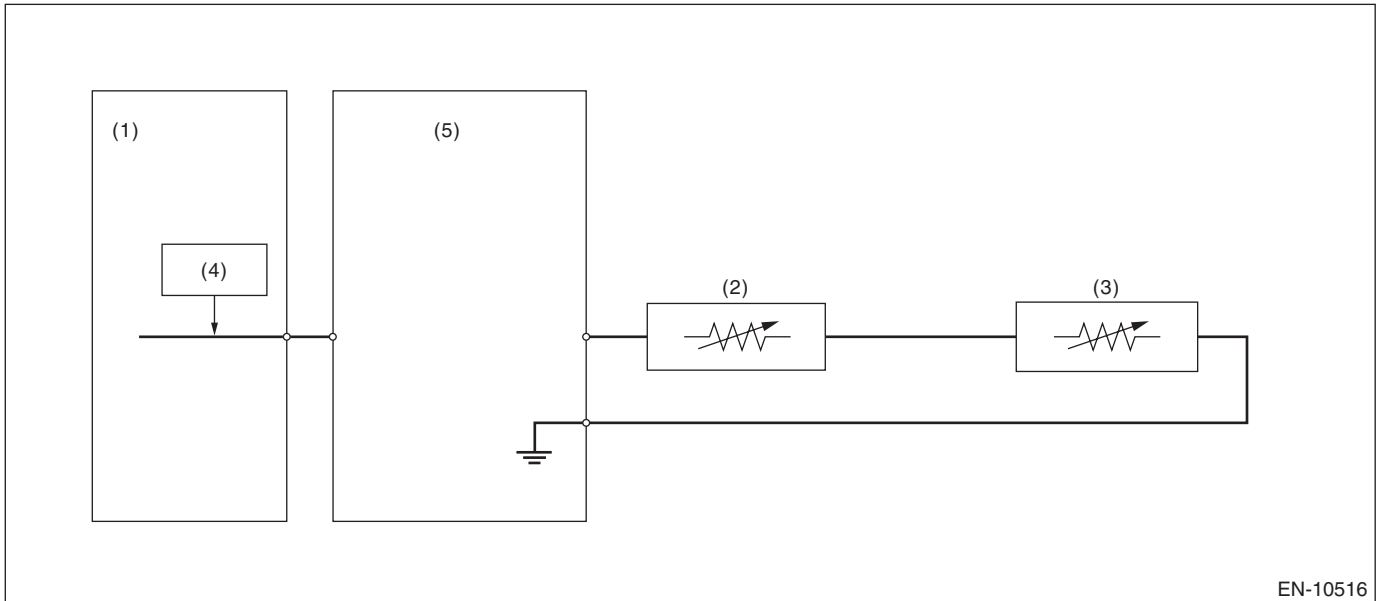

- (1) Engine control module (ECM)      (3) Fuel level sensor      (5) Combination meter  
 (2) Fuel sub level sensor      (4) Detecting circuit

### 3. ENABLE CONDITIONS

Secondary Parameters	Enable Conditions
Battery voltage	≥ 10.9 V
Elapsed time after starting the engine	≥ 3000 ms

### 4. GENERAL DRIVING CYCLE

Always perform the diagnosis continuously.

### 5. DIAGNOSTIC METHOD

If the duration of time while the following conditions are met is longer than the time indicated, judge as NG.

#### Judgment Value

Malfunction Criteria	Threshold Value
Output voltage	< 2.21 V

**Time Needed for Diagnosis:** 2560 ms

**Malfunction Indicator Light Illumination:** Illuminates when malfunction occurs in 2 continuous driving cycles.

# Diagnostic Trouble Code (DTC) Detecting Criteria

## GENERAL DESCRIPTION

### DO:DTC P0463 FUEL LEVEL SENSOR “A” CIRCUIT HIGH

#### 1. OUTLINE OF DIAGNOSIS

Detect the open or short circuit of fuel level sensor. Judge as NG if out of specification.

#### 2. COMPONENT DESCRIPTION

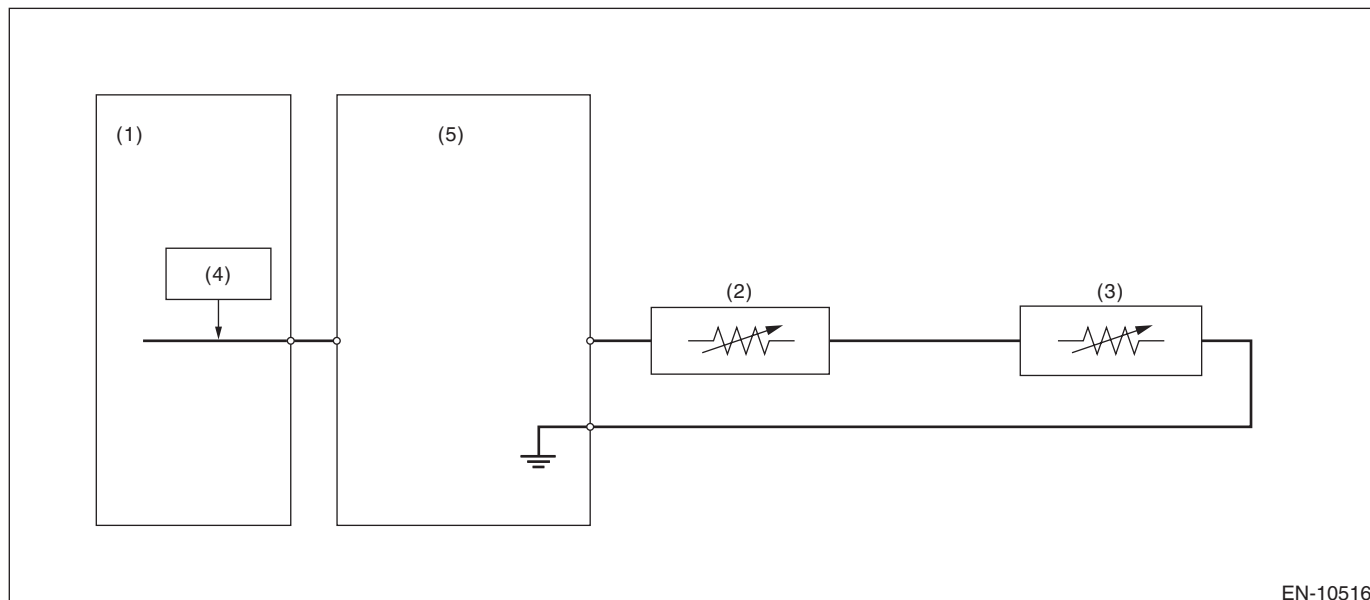

- (1) Engine control module (ECM)      (3) Fuel level sensor      (5) Combination meter  
 (2) Fuel sub level sensor      (4) Detecting circuit

#### 3. ENABLE CONDITIONS

Secondary Parameters	Enable Conditions
Battery voltage	≥ 10.9 V
Elapsed time after starting the engine	≥ 3000 ms

#### 4. GENERAL DRIVING CYCLE

Always perform the diagnosis continuously.

#### 5. DIAGNOSTIC METHOD

If the duration of time while the following conditions are met is longer than the time indicated, judge as NG.

##### Judgment Value

Malfunction Criteria	Threshold Value
Output voltage	> 12 V

**Time Needed for Diagnosis:** 1040 ms

**Malfunction Indicator Light Illumination:** Illuminates when malfunction occurs in 2 continuous driving cycles.

# Diagnostic Trouble Code (DTC) Detecting Criteria

GENERAL DESCRIPTION

## DP:DTC P0500 VEHICLE SPEED SENSOR “A”

### 1. OUTLINE OF DIAGNOSIS

Judge as NG when outside of the judgment value.

Judge NG when the received data from VDCCM&H/U is abnormal vehicle speed, and the vehicle speed data is impossible.

### 2. COMPONENT DESCRIPTION

Vehicle speed signals are taken in to the VDC control module and hydraulic control unit, and normal/erroneous data of the ABS wheel speed sensor is received by CAN communication from the VDC control module and hydraulic control unit.

### 3. ENABLE CONDITIONS

Secondary Parameters	Enable Conditions
Battery voltage	$\geq 10.9$ V

### 4. GENERAL DRIVING CYCLE

Always perform the diagnosis continuously after the enable conditions have been established.

### 5. DIAGNOSTIC METHOD

If the duration of time while the following conditions are met is longer than the time indicated, judge as NG.

#### Judgment Value

Malfunction Criteria	Threshold Value
Speed of RH wheel received from VDC control module & hydraulic control unit	$\geq 300$ km/h (186.4 MPH)

**Time Needed for Diagnosis:** 2560 ms

**Malfunction Indicator Light Illumination:** Illuminates as soon as a malfunction occurs.

# Diagnostic Trouble Code (DTC) Detecting Criteria

## GENERAL DESCRIPTION

### DQ:DTC P0506 IDLE AIR CONTROL SYSTEM RPM LOWER THAN EXPECTED

#### 1. OUTLINE OF DIAGNOSIS

Detect the malfunction that actual engine speed is not close to target engine speed during idling. Judge as NG when actual engine speed is not close to target engine speed during idling.

#### 2. ENABLE CONDITIONS

Secondary Parameters	Enable Conditions
Fuel level	≥ 9 L (2.38 US gal, 1.98 Imp gal)
Atmospheric pressure	≥ 75.06 kPa (563 mmHg, 22.2 inHg)
Battery voltage	≥ 10.9 V
Engine coolant temperature	≥ 60°C (140°F)
Elapsed time after starting the engine	≥ 10.5 s
Accelerator pedal position	= 0%
Lambda value (left and right)	≥ 0.851 and < 1.151
Elapsed time after intake manifold pressure changes by 4 kPa (30 mmHg, 1.2 inHg) or more	> 5.1 s
Vehicle speed	0 km/h (0 MPH)
Elapsed time after switching neutral position switch to ON/OFF	> 5.1 s
Cold start diagnosis	Not in operation

#### 3. GENERAL DRIVING CYCLE

Perform the diagnosis continuously at idling after warming up engine.

#### 4. DIAGNOSTIC METHOD

If the duration of time while the following conditions are met is longer than the time indicated, judge as NG.

##### Judgment Value

Malfunction Criteria	Threshold Value
Actual engine speed – Target engine speed	< – 100 rpm

**Time Needed for Diagnosis:** 15 seconds

**Malfunction Indicator Light Illumination:** Illuminates when malfunction occurs in 2 continuous driving cycles.



# Diagnostic Trouble Code (DTC) Detecting Criteria

GENERAL DESCRIPTION

## DR:DTC P0507 IDLE AIR CONTROL SYSTEM RPM HIGHER THAN EXPECTED

### 1. OUTLINE OF DIAGNOSIS

Detect the malfunction that actual engine speed is not close to target engine speed during idling. Judge as NG when actual engine speed is not close to target engine speed during idling.

### 2. ENABLE CONDITIONS

Secondary Parameters	Enable Conditions
Fuel level	≥ 9 L (2.38 US gal, 1.98 Imp gal)
Atmospheric pressure	≥ 75.06 kPa (563 mmHg, 22.2 inHg)
Battery voltage	≥ 10.9 V
Engine coolant temperature	≥ 60°C (140°F)
Elapsed time after starting the engine	≥ 10.5 s
Accelerator pedal position	= 0%
Lambda value (left and right)	≥ 0.851 and < 1.151
Elapsed time after intake manifold pressure changes by 4 kPa (30 mmHg, 1.2 inHg) or more	> 5.1 s
Vehicle speed	0 km/h (0 MPH)
Elapsed time after switching neutral position switch to ON/OFF	> 5.1 s
Cold start diagnosis	Not in operation

### 3. GENERAL DRIVING CYCLE

Perform the diagnosis continuously at idling after warming up engine.

### 4. DIAGNOSTIC METHOD

If the duration of time while the following conditions are met is longer than the time indicated, judge as NG.

#### Judgment Value

Malfunction Criteria	Threshold Value
Actual engine speed – Target engine speed	> 200 rpm

**Time Needed for Diagnosis:** 15 seconds

**Malfunction Indicator Light Illumination:** Illuminates when malfunction occurs in 2 continuous driving cycles.

# Diagnostic Trouble Code (DTC) Detecting Criteria

## GENERAL DESCRIPTION

### DS:DTC P050A COLD START IDLE AIR CONTROL SYSTEM PERFORMANCE

#### 1. OUTLINE OF DIAGNOSIS

- When cold, the abnormality in the control of target engine speed increase is detected. (P050A)

Judge as NG if the idle speed diagnosis is NG.

- Idle speed diagnosis

Judge as NG when actual engine speed is not close to target engine speed at cold start.

- Detect malfunctions of the catalyst advanced idling retard angle control. (P050B)

Judge as NG when ECM is not controlling the angle properly during catalyst advanced idling retard angle control.

- Final ignition timing diagnosis

Judge as NG when actual retard amount is under the specified value at cold start.

#### 2. ENABLE CONDITIONS

Secondary Parameters	Enable Conditions
<Idle speed diagnosis>	
Atmospheric pressure	≥ 75 kPa (563 mmHg, 22.2 inHg)
Battery voltage	≥ 10.9 V
Vehicle speed	≤ 2 km/h (1.3 MPH)
Engine coolant temperature	≤ 75°C (167°F)
Intake air amount sum value	< Value from Map
Elapsed time after gear position change (P ↔ D or N ↔ D)	≥ 3000 ms
Throttle opening angle	< 0.312%
Elapsed time after starting the engine	≥ 2000 ms
<Final ignition timing diagnosis>	
Atmospheric pressure	≥ 75 kPa (563 mmHg, 22.2 inHg)
Battery voltage	≥ 10.9 V
Vehicle speed	≤ 2 km/h (1.3 MPH)
Engine coolant temperature	≤ 75°C (167°F)
Intake air amount sum value	< Value from Map
Elapsed time after gear position change (P ↔ D or N ↔ D)	≥ 3000 ms
Throttle opening angle	< 0.312%
Target retard amount	≥ 10°CA

#### Map

Engine coolant temperature at engine starting °C (°F)	-40 (-40)	-30 (-22)	-20 (-4)	-10 (-14)	0 (32)	10 (50)	20 (68)	30 (86)
Intake air amount sum value g (oz)	723 (25.5)	723 (25.5)	603 (21.27)	683 (24.09)	710 (25.04)	687 (24.23)	570 (20.1)	607 (21.41)

Engine coolant temperature at engine starting °C (°F)	40 (104)	50 (122)	60 (140)	70 (158)	75 (167)
Intake air amount sum value g (oz)	607 (21.41)	607 (21.41)	553 (19.5)	467 (16.47)	467 (16.47)

#### 3. GENERAL DRIVING CYCLE

Perform the diagnosis at cold start.

# Diagnostic Trouble Code (DTC) Detecting Criteria

GENERAL DESCRIPTION

## 4. DIAGNOSTIC METHOD

### • Idle speed diagnosis

Judge as NG when the following conditions are established.

#### Judgment Value

Malfunction Criteria	Threshold Value
Actual engine speed – Target engine speed	< – 300 rpm

**Time Needed for Diagnosis:** 7 seconds

**Malfunction Indicator Light Illumination:** Illuminates when malfunction occurs in 2 continuous driving cycles.

### • Final ignition timing diagnosis

Judge as NG when the following conditions are established.

#### Judgment Value

Malfunction Criteria	Threshold Value
Final ignition timing – ignition timing during CSERS* *: Ignition timing during CSERS (Cold Start Emission Reduction Strategy) = Base ignition timing – retard amount	> 12°CA

**Time Needed for Diagnosis:** 7 seconds

**Malfunction Indicator Light Illumination:** Illuminates when malfunction occurs in 2 continuous driving cycles.

## DT:DTC P050B COLD START IGNITION TIMING PERFORMANCE

### 1. OUTLINE OF DIAGNOSIS

NOTE:

For the detection standard, refer to DTC P050A. <Ref. to GD(w/o STI)-148, DTC P050A COLD START IDLE AIR CONTROL SYSTEM PERFORMANCE, Diagnostic Trouble Code (DTC) Detecting Criteria.>

# Diagnostic Trouble Code (DTC) Detecting Criteria

## GENERAL DESCRIPTION

---

### DU:DTC P0512 STARTER REQUEST CIRCUIT

#### 1. OUTLINE OF DIAGNOSIS

Detect abnormal continuity in the starter SW.

Judge as ON NG when the starter SW signal remains ON.

#### 2. ENABLE CONDITIONS

Secondary Parameters	Enable Conditions
Battery voltage	$\geq 8 \text{ V}$
Engine speed	$> 500 \text{ rpm}$

#### 3. GENERAL DRIVING CYCLE

Always perform the diagnosis continuously.

#### 4. DIAGNOSTIC METHOD

If the duration of time while the following conditions are met is longer than the time indicated, judge as ON NG.

#### Judgment Value

Malfunction Criteria	Threshold Value
Starter SW1 voltage	$\geq 6 \text{ V}$

**Time Needed for Diagnosis:** 30 seconds

**Malfunction Indicator Light Illumination:** Illuminates as soon as a malfunction occurs.

# Diagnostic Trouble Code (DTC) Detecting Criteria

GENERAL DESCRIPTION

## DV:DTC P0560 SYSTEM VOLTAGE

### 1. OUTLINE OF DIAGNOSIS

Detect the open/short circuit of back-up power supply circuit.  
Judge as NG when the backup power voltage is low.

### 2. ENABLE CONDITIONS

Secondary Parameters	Enable Conditions
Engine speed	> 500 rpm
Battery voltage	≥ 10.9 V

### 3. GENERAL DRIVING CYCLE

Perform the diagnosis continuously after starting the engine.

### 4. DIAGNOSTIC METHOD

If the duration of time while the following conditions are met is longer than the time indicated, judge as NG.

#### Judgment Value

Malfunction Criteria	Threshold Value
Voltage of back-up power supply	< 6 V

**Time Needed for Diagnosis:** 2560 ms

**Malfunction Indicator Light Illumination:** Illuminates as soon as a malfunction occurs.

# Diagnostic Trouble Code (DTC) Detecting Criteria

## GENERAL DESCRIPTION

---

### DW:DTC P0604 INTERNAL CONTROL MODULE RANDOM ACCESS MEMORY (RAM) ERROR

#### 1. OUTLINE OF DIAGNOSIS

Detect the malfunction of microcomputer (RAM).

When there is a problem in the CPU normal RAM, judge as NG.

If it is possible to write data to the whole area of RAM in the initial routine, and is possible to read the same data, it is judged as OK, and if not, NG.

#### 2. ENABLE CONDITIONS

Secondary Parameters	Enable Conditions
ECM initialization	Executed

Diagnosis with the initial routine.

#### 3. GENERAL DRIVING CYCLE

Perform the diagnosis as soon as the ignition switch is turned to ON.

#### 4. DIAGNOSTIC METHOD

Judge as NG when the following conditions are established.

##### Judgment Value

Malfunction Criteria	Threshold Value
Write the specified value into the RAM.	Different from written value

**Time Needed for Diagnosis:** Less than 1 second

**Malfunction Indicator Light Illumination:** Illuminates as soon as a malfunction occurs.

# Diagnostic Trouble Code (DTC) Detecting Criteria

GENERAL DESCRIPTION

## **DX:DTC P0605 INTERNAL CONTROL MODULE READ ONLY MEMORY (ROM) ERROR**

### **1. OUTLINE OF DIAGNOSIS**

Judge as NG when SUM value of ROM is outside the standard value.

### **2. ENABLE CONDITIONS**

Secondary Parameters	Enable Conditions
ECM initialization	Executed

### **3. GENERAL DRIVING CYCLE**

Perform the diagnosis when the ignition switch is turned from OFF to ON.

### **4. DIAGNOSTIC METHOD**

Judge as NG if the criteria below are met.

#### **Judgment Value**

Malfunction Criteria	Threshold Value
SUM value of ROM	Malfunction

**Time Needed for Diagnosis:** Less than 1 second

**Malfunction Indicator Light Illumination:** Illuminates as soon as a malfunction occurs.

# Diagnostic Trouble Code (DTC) Detecting Criteria

## GENERAL DESCRIPTION

### DY:DTC P0606 CONTROL MODULE PROCESSOR

#### 1. OUTLINE OF DIAGNOSIS

Judge as NG when any one of the followings is established.

- (1) When the input amplifier circuit operation of throttle position sensor 1 is abnormal.
- (2) When the learning value of backup RAM is incorrect.
- (3) When SUM value of backup RAM is outside the standard value.
- (4) When the communication between main CPU and sub CPU is abnormal.
- (5) If the CPU operation is abnormal
- (6) If the CPU operation is abnormal (FPU check).

#### 2. ENABLE CONDITIONS

Secondary Parameters	Enable Conditions
(1) ECM initialization	Executed
(2) Ignition switch	OFF → ON
(3) ECM initialization	Executed
(4) Battery voltage	≥ 6 V
(5) Battery voltage	≥ 6 V
(6) Battery voltage	≥ 6 V

#### 3. GENERAL DRIVING CYCLE

- (1) Perform the diagnosis only once.
- (2) Always perform the diagnosis continuously.
- (3) Perform the diagnosis only once.
- (4) Always perform the diagnosis continuously.
- (5) Always perform the diagnosis continuously.
- (6) Always perform the diagnosis continuously.

#### 4. DIAGNOSTIC METHOD

Judge as NG if the criteria below are met.

##### Judgment Value

Malfunction Criteria	Threshold Value
(1) Throttle minimum stop position	≥ 2.2 V
(2) The learned value of accelerator pedal position in back-up RAM area 1	≠ The learned value of accelerator pedal position in back-up RAM area 2
(3) The sum of back-up RAM at the ECM shut down	≠ The sum of back-up RAM at the ECM powered-on
(4) Communication between main CPU and sub CPU	Lost
(5) The calculated data of throttle control by main CPU	≠ The calculated data of throttle control by sub CPU
(6) The calculated data by main CPU	≠ The calculated data by FPU

##### Time Needed for Diagnosis:

- (1): Less than 1 second
- (2): Less than 1 second
- (3): Less than 1 second
- (4): Less than 1 second
- (5): Less than 1 second
- (6): 200 ms

**Malfunction Indicator Light Illumination:** Illuminates as soon as a malfunction occurs.



# Diagnostic Trouble Code (DTC) Detecting Criteria

GENERAL DESCRIPTION

## DZ:DTC P060A INTERNAL CONTROL MODULE MONITORING PROCESSOR PERFORMANCE

### 1. OUTLINE OF DIAGNOSIS

Judge as NG when the monitoring IC operation is abnormal.

### 2. ENABLE CONDITIONS

Secondary Parameters	Enable Conditions
None	

### 3. GENERAL DRIVING CYCLE

Always perform the diagnosis continuously.

### 4. DIAGNOSTIC METHOD

Judge as NG when one of the following conditions is established.

#### Judgment Value

Malfunction Criteria	Threshold Value
Communication status between main CPU and sub CPU	Malfunction

**Time Needed for Diagnosis:** Less than 1 second

**Malfunction Indicator Light Illumination:** Illuminates as soon as a malfunction occurs.

# Diagnostic Trouble Code (DTC) Detecting Criteria

## GENERAL DESCRIPTION

---

### EA:DTC P060B INTERNAL CONTROL MODULE A/D PROCESSING PERFORMANCE

#### 1. OUTLINE OF DIAGNOSIS

Judge as NG when the AD converter operation is abnormal.

#### 2. ENABLE CONDITIONS

Secondary Parameters	Enable Conditions
Battery voltage	$\geq 6 \text{ V}$
$ A/D \text{ for control} - \text{Last value of A/D for control} $	$\geq 0.5 \text{ V}$

#### 3. GENERAL DRIVING CYCLE

Always perform the diagnosis continuously.

#### 4. DIAGNOSTIC METHOD

Judge as NG when one of the following conditions is established.

##### Judgment Value

Malfunction Criteria	Threshold Value
Change amount of A/D for control	$\leq 0.2 \text{ V}$
Change amount of A/D for monitoring	$\leq 0.2 \text{ V}$

**Time Needed for Diagnosis:** 200 ms

**Malfunction Indicator Light Illumination:** Illuminates as soon as a malfunction occurs.

# Diagnostic Trouble Code (DTC) Detecting Criteria

GENERAL DESCRIPTION

## EB:DTC P0616 STARTER RELAY CIRCUIT LOW

### 1. OUTLINE OF DIAGNOSIS

Detect abnormal continuity in the starter SW 2.

Judge as OFF NG when the starter SW 2 signal remains OFF.

### 2. ENABLE CONDITIONS

Secondary Parameters	Enable Conditions
Battery voltage	≥ 8 V
Vehicle speed	< 1 km/h (0.6 MPH)
Engine speed	Increases from 0 rpm to 500 rpm or more
Starter relay	ON

### 3. GENERAL DRIVING CYCLE

Perform the diagnosis only once after starting the engine.

### 4. DIAGNOSTIC METHOD

Judge as OFF NG when the following conditions are established.

#### Judgment Value

Malfunction Criteria	Threshold Value
Starter SW2 signal of 6 V or more	Not detected

**Time Needed for Diagnosis:** Less than 1 second

**Malfunction Indicator Light Illumination:** Illuminates as soon as a malfunction occurs.

# Diagnostic Trouble Code (DTC) Detecting Criteria

## GENERAL DESCRIPTION

---

### EC:DTC P0617 STARTER RELAY CIRCUIT HIGH

#### 1. OUTLINE OF DIAGNOSIS

Detect abnormal continuity in the starter SW 2.

Judge as ON NG when the starter SW 2 signal remains ON.

#### 2. ENABLE CONDITIONS

Secondary Parameters	Enable Conditions
Battery voltage	≥ 8 V
Engine speed	> 500 rpm
Starter relay	OFF

#### 3. GENERAL DRIVING CYCLE

Perform the diagnosis continuously after starting the engine.

#### 4. DIAGNOSTIC METHOD

If the duration of time while the following conditions are met is longer than the time indicated, judge as NG.

##### Judgment Value

Malfunction Criteria	Threshold Value
Starter SW2 signal	≥ 6 V

**Time Needed for Diagnosis:** 30 seconds

**Malfunction Indicator Light Illumination:** Illuminates as soon as a malfunction occurs.

# Diagnostic Trouble Code (DTC) Detecting Criteria

GENERAL DESCRIPTION

## ED:DTC P062D FUEL INJECTOR DRIVER CIRCUIT PERFORMANCE (BANK 1)

### 1. OUTLINE OF DIAGNOSIS

Detect the malfunction of fuel injector circuit function.

Judge as NG when ECM with two fuel injectors or more detects any malfunction in the diagnostic items listed below.

Diagnostic item	Malfunction Criteria
Overcurrent	Fuel injector current is high.
Low current	Fuel injector current is low.

### 2. ENABLE CONDITIONS

Secondary Parameters	Enable Conditions
Battery voltage	≥ 9.4 V
Engine speed	> 0 rpm
Fuel cut	Not performed

### 3. GENERAL DRIVING CYCLE

Always perform the diagnosis continuously.

### 4. DIAGNOSTIC METHOD

If the duration of time while the following conditions are met is longer than the time indicated, judge as NG.

#### Diagnosis for Overcurrent

##### Judgment Value

Malfunction Criteria	Threshold Value
Fuel injector current	≥ 18 A

#### Low Current Diagnosis

##### Judgment Value

Malfunction Criteria	Threshold Value
Fuel injector current	≤ 8.8 A

**Time Needed for Diagnosis:** TDC × 50 times

**Malfunction Indicator Light Illumination:** Illuminates as soon as a malfunction occurs.

# Diagnostic Trouble Code (DTC) Detecting Criteria

## GENERAL DESCRIPTION

---

### EE:DTC P062F INTERNAL CONTROL MODULE EEPROM ERROR

#### 1. OUTLINE OF DIAGNOSIS

Judge as NG when the EEPROM operation is abnormal.

#### 2. ENABLE CONDITIONS

Secondary Parameters	Enable Conditions
None	

#### 3. GENERAL DRIVING CYCLE

Perform the diagnosis during self shut.

#### 4. DIAGNOSTIC METHOD

Judge as NG when the following conditions are established.

##### Judgment Value

Malfunction Criteria	Threshold Value
Writing result to EEPROM	Malfunction

**Time Needed for Diagnosis:** Less than 1 second

**Malfunction Indicator Light Illumination:** Illuminates as soon as a malfunction occurs.

# Diagnostic Trouble Code (DTC) Detecting Criteria

GENERAL DESCRIPTION

## EF:DTC P0685 ECM/PCM POWER RELAY CONTROL CIRCUIT/OPEN

### 1. OUTLINE OF DIAGNOSIS

Detect the main relay stuck to ON.

Judge as NG when ECM keeps operating for more than predetermined time although the main relay does not turn to OFF after ignition switch is turned to OFF.

### 2. COMPONENT DESCRIPTION

The main relay controls current of coils by receiving instructions from the ignition switch and ELCM to switch ECM to ON/OFF.

### 3. ENABLE CONDITIONS

Secondary Parameters	Enable Conditions
Main relay	OFF instruction

### 4. GENERAL DRIVING CYCLE

Perform the diagnosis only once when the following driving cycle starts after the ignition switch is OFF.

### 5. DIAGNOSTIC METHOD

If the duration of time while the following conditions are met is longer than the time indicated, judge as NG.

#### Judgment Value

Malfunction Criteria	Threshold Value
ECM status	In operation

**Time Needed for Diagnosis:** 2.5 seconds

**Malfunction Indicator Light Illumination:** Illuminates when malfunction occurs in 2 continuous driving cycles.

# Diagnostic Trouble Code (DTC) Detecting Criteria

## GENERAL DESCRIPTION

---

### EG:DTC P0700 TRANSMISSION CONTROL SYSTEM (MIL REQUEST)

#### 1. OUTLINE OF DIAGNOSIS

Judge as NG when there is CAN communication with the TCM and there is a MIL lighting request.

#### 2. ENABLE CONDITIONS

Secondary Parameters	Enable Conditions
Battery voltage	$\geq 10.9$ V

#### 3. GENERAL DRIVING CYCLE

Always perform the diagnosis continuously.

#### 4. DIAGNOSTIC METHOD

If the duration of time while the following conditions are met is longer than the time indicated, judge as NG.

#### Judgment Value

Malfunction Criteria	Threshold Value
MIL lighting request from TCM	Yes

**Time Needed for Diagnosis:** 2560 ms

**Malfunction Indicator Light Illumination:** Illuminates as soon as a malfunction occurs.



# Diagnostic Trouble Code (DTC) Detecting Criteria

GENERAL DESCRIPTION

## EH:DTC P081A STARTER DISABLE CIRCUIT LOW

### 1. OUTLINE OF DIAGNOSIS

Detect abnormal continuity in the starter cut relay.

Judge as NG when the starter cut relay output line is open.

### 2. ENABLE CONDITIONS

Secondary Parameters	Enable Conditions
Battery voltage	≥ 8 V
Vehicle speed	< 1 km/h (0.6 MPH)
Starter cut relay	OFF
Engine speed	Increases from 0 rpm to 500 rpm or more

### 3. GENERAL DRIVING CYCLE

Perform the diagnosis only once when the engine condition is turned from before starting to after starting.

### 4. DIAGNOSTIC METHOD

Judge as NG when the following conditions are established.

#### Judgment Value

Malfunction Criteria	Threshold Value
Starter cut relay control signal that exceeds 3.2 V	Not detected

**Time Needed for Diagnosis:** 2500 ms

**Malfunction Indicator Light Illumination:** Illuminates as soon as a malfunction occurs.

# Diagnostic Trouble Code (DTC) Detecting Criteria

## GENERAL DESCRIPTION

### EI: DTC P0851 PARK/NEUTRAL SWITCH INPUT CIRCUIT LOW (AT MODEL)

#### 1. OUTLINE OF DIAGNOSIS

Detect the open or short circuit of neutral SW.

Judge as NG when the ECM neutral terminal input differs from the reception data from TCM.

#### 2. ENABLE CONDITIONS

Secondary Parameters	Enable Conditions
Battery voltage	$\geq 10.9 \text{ V}$
Starter relay feedback voltage	$< 1.5 \text{ V}$
Engine speed	$\geq 500 \text{ rpm}$
Data received from TCM	$\neq$ "P" range/"N" range

#### 3. GENERAL DRIVING CYCLE

Perform the diagnosis only once after the enable conditions have been established.

#### 4. DIAGNOSTIC METHOD

If the duration of time while the following conditions are met is longer than the time indicated, judge as NG.

##### Judgment Value

Malfunction Criteria	Threshold Value
Neutral position switch voltage	$\leq 1 \text{ V}$

**Time Needed for Diagnosis:** 80 ms  $\times$  80 time(s)

**Malfunction Indicator Light Illumination:** Illuminates when malfunction occurs in 2 continuous driving cycles.

# Diagnostic Trouble Code (DTC) Detecting Criteria

GENERAL DESCRIPTION

## EJ: DTC P0851 NEUTRAL SWITCH INPUT CIRCUIT LOW (MT MODEL)

### 1. OUTLINE OF DIAGNOSIS

Detect the open or short circuit of neutral SW.

Judge as NG when there is no change in the neutral SW even if the driving shift was applied. (There is neutral SW ON/OFF inversion from the vehicle speed and engine speed.)

### 2. ENABLE CONDITIONS

Secondary Parameters	Enable Conditions
Battery voltage Change from driving condition a) to b) a) Engine speed 600 — 900 rpm & Vehicle speed = 0 km/h (0 MPH) b) Engine speed 1450 — 2250 rpm & Vehicle speed $\geq$ 64 km/h (39.8 MPH)	$\geq$ 10.9 V = 3 times

### 3. GENERAL DRIVING CYCLE

Perform the diagnosis only once after the enable conditions have been established.

### 4. DIAGNOSTIC METHOD

Judge NG when the malfunction criteria below are completed determined times or more after the neutral SW change.

#### Judgment Value

Malfunction Criteria	Threshold Value
Neutral switch output voltage	$\leq$ 1 V

**Time Needed for Diagnosis:** 3 times

**Malfunction Indicator Light Illumination:** Illuminates when malfunction occurs in 2 continuous driving cycles.

# Diagnostic Trouble Code (DTC) Detecting Criteria

## GENERAL DESCRIPTION

### EK:DTC P0852 PARK/NEUTRAL SWITCH INPUT CIRCUIT HIGH (AT MODEL)

#### 1. OUTLINE OF DIAGNOSIS

Detect the open or short circuit of neutral SW.

Judge as NG when the ECM neutral terminal input differs from the reception data from TCM.

#### 2. ENABLE CONDITIONS

Secondary Parameters	Enable Conditions
Battery voltage	≥ 10.9 V
Starter relay feedback voltage	< 1.5 V
Engine speed	≥ 500 rpm
Data received from TCM	= "P" range/"N" range

#### 3. GENERAL DRIVING CYCLE

Perform the diagnosis only once after the enable conditions have been established.

#### 4. DIAGNOSTIC METHOD

If the duration of time while the following conditions are met is longer than the time indicated, judge as NG.

##### Judgment Value

Malfunction Criteria	Threshold Value
Neutral position switch voltage	≥ 6.6 V

**Time Needed for Diagnosis:** 80 ms × 80 time(s)

**Malfunction Indicator Light Illumination:** Illuminates when malfunction occurs in 2 continuous driving cycles.

# Diagnostic Trouble Code (DTC) Detecting Criteria

GENERAL DESCRIPTION

## EL:DTC P0852 NEUTRAL SWITCH INPUT CIRCUIT HIGH (MT MODEL)

### 1. OUTLINE OF DIAGNOSIS

Detect the open or short circuit of neutral SW.

Judge as NG when there is no change in the neutral SW even if the driving shift was applied. (There is neutral SW ON/OFF inversion from the vehicle speed and engine speed.)

### 2. ENABLE CONDITIONS

Secondary Parameters	Enable Conditions
Battery voltage Change from driving condition a) to b) a) Engine speed 600 — 900 rpm & Vehicle speed = 0 km/h (0 MPH) b) Engine speed 1450 — 2250 rpm & Vehicle speed $\geq$ 64 km/h (39.8 MPH)	$\geq$ 10.9 V = 3 times

### 3. GENERAL DRIVING CYCLE

Perform the diagnosis only once after the enable conditions have been established.

### 4. DIAGNOSTIC METHOD

Judge NG when the malfunction criteria below are completed determined times or more after the neutral SW change.

#### Judgment Value

Malfunction Criteria	Threshold Value
Neutral switch output voltage	$\geq$ 6.6 V

**Time Needed for Diagnosis:** 3 times

**Malfunction Indicator Light Illumination:** Illuminates when malfunction occurs in 2 continuous driving cycles.

# Diagnostic Trouble Code (DTC) Detecting Criteria

## GENERAL DESCRIPTION

---

### EM:DTC P1134 A/F SENSOR MICRO-COMPUTER PROBLEM

#### 1. OUTLINE OF DIAGNOSIS

Judge as NG when the A/F sensor microcomputer operation is abnormal.

#### 2. ENABLE CONDITIONS

Secondary Parameters	Enable Conditions
None	

#### 3. GENERAL DRIVING CYCLE

Always perform the diagnosis continuously.

#### 4. DIAGNOSTIC METHOD

Judge as NG when the following conditions are established.

##### Judgment Value

Malfunction Criteria	Threshold Value
Communication status between CPU and A/F sensor microcomputer	Malfunction

**Time Needed for Diagnosis:** 80 ms

**Malfunction Indicator Light Illumination:** Illuminates as soon as a malfunction occurs.

# Diagnostic Trouble Code (DTC) Detecting Criteria

GENERAL DESCRIPTION

## EN:DTC P113A O2 SENSOR CIRCUIT (OPEN) (BANK1 SENSOR2)

### 1. OUTLINE OF DIAGNOSIS

Detect open circuit of the rear oxygen sensor. Judge as NG when the rear oxygen sensor voltage can be determined as abnormal while observing the way the rear oxygen sensor gets energized.

### 2. COMPONENT DESCRIPTION

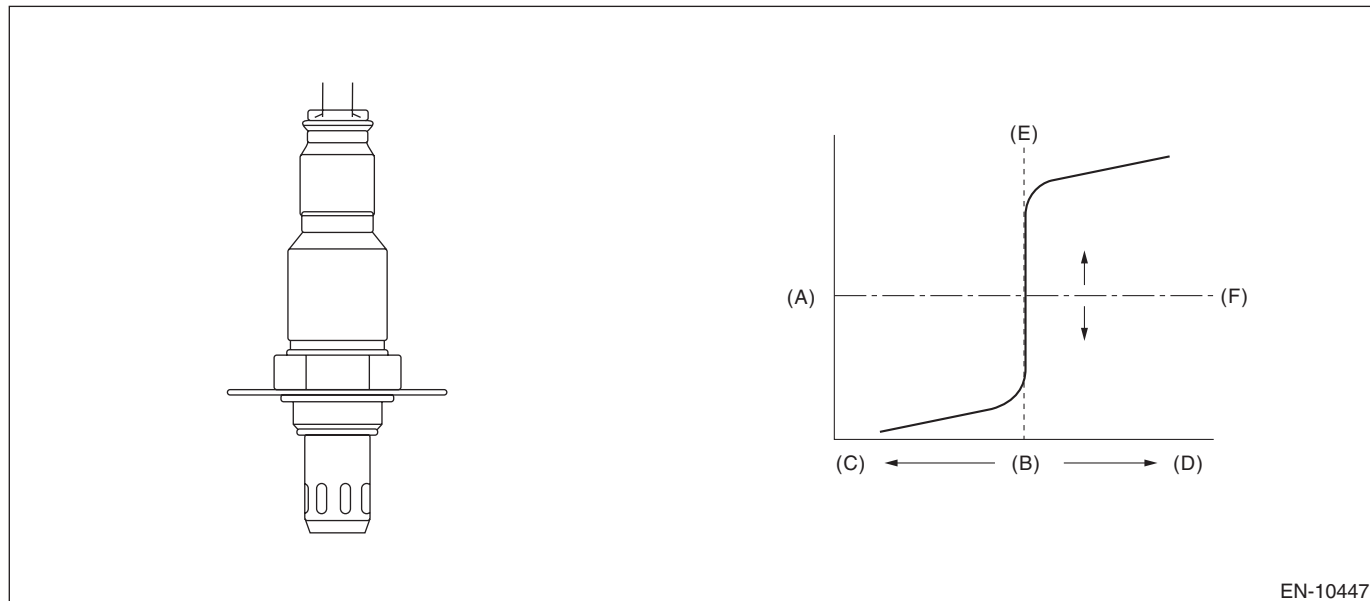

EN-10447

(A) Electromotive force

(B) Air fuel ratio

(C) Lean

(D) Rich

(E) Theoretical air fuel ratio

(F) Comparative voltage

### 3. ENABLE CONDITIONS

Secondary Parameters	Enable Conditions
Engine speed	$\geq 500$ rpm
Battery voltage	$\geq 10.9$ V
Continuous time when the rear oxygen sensor heater control duty exceeds 0%	$\geq 21.8$ s
Accumulated duty ratio of energized rear oxygen sensor heater since engine start	$\geq 54400\%$
Rear oxygen sensor offset signal	1.7 — 2.3 V

### 4. GENERAL DRIVING CYCLE

Always perform the diagnosis continuously after the enable conditions have been established.

### 5. DIAGNOSTIC METHOD

If the duration of time while the following conditions are met is longer than the time indicated, judge as NG.

#### Judgment Value

Malfunction Criteria	Threshold Value
Rear oxygen sensor signal	$< 1.7$ V

**Time Needed for Diagnosis:** 1 second

**Malfunction Indicator Light Illumination:** Illuminates when malfunction occurs in 2 continuous driving cycles.

# Diagnostic Trouble Code (DTC) Detecting Criteria

## GENERAL DESCRIPTION

---

### EO:DTC P1160 RETURN SPRING FAILURE

#### 1. OUTLINE OF DIAGNOSIS

Judge as NG when the throttle opening angle is out of specified value with ignition switch OFF.

#### 2. ENABLE CONDITIONS

Secondary Parameters	Enable Conditions
Ignition switch	OFF
Continuous time when throttle motor control duty is 0%	= 7.82 s

#### 3. GENERAL DRIVING CYCLE

Perform the diagnosis when the ignition switch is turned from ON to OFF.

#### 4. DIAGNOSTIC METHOD

Judge as NG when the following conditions are established.

##### Judgment Value

Malfunction Criteria	Threshold Value
Throttle opening angle	< 13.9% or > 20.6%

**Time Needed for Diagnosis:** Less than 1 second

**Malfunction Indicator Light Illumination:** Illuminates as soon as a malfunction occurs.



# Diagnostic Trouble Code (DTC) Detecting Criteria

GENERAL DESCRIPTION

## EP:DTC P1261 DI INJECTOR CIRCUIT / OPEN - (CYLINDER 1)

### 1. OUTLINE OF DIAGNOSIS

Detect the malfunction of fuel injector circuit function.

Judge as NG when ECM detects any malfunction in the diagnostic items listed below.

Diagnostic item	Malfunction Criteria
Power supply short	ECM low side terminal voltage of the fuel injector circuit is high.
Ground short	ECM low side terminal voltage of the fuel injector circuit is low.
Open circuit	Fuel injector current is low.
Overcurrent	Fuel injector current is high.
Short circuit	The time when the fuel injector current reaches the target current is short.

### 2. ENABLE CONDITIONS

Secondary Parameters	Enable Conditions
Battery voltage	$\geq 9.4$ V
Engine speed	$> 0$ rpm
Fuel cut	Not performed

### 3. GENERAL DRIVING CYCLE

Always perform the diagnosis continuously.

### 4. DIAGNOSTIC METHOD

If the duration of time while the following conditions are met is longer than the time indicated, judge as NG.

#### Diagnosis for Power Supply Short

##### Judgment Value

Malfunction Criteria	Threshold Value
Terminal voltage	$\geq 4.1$ V

#### Diagnosis for Ground Short

##### Judgment Value

Malfunction Criteria	Threshold Value
Terminal voltage	$\leq 0.8$ V

#### Diagnosis for Open Circuit

##### Judgment Value

Malfunction Criteria	Threshold Value
Fuel injector current	$\leq 0.5$ A

#### Diagnosis for Overcurrent

##### Judgment Value

Malfunction Criteria	Threshold Value
Fuel injector current	$\geq 22$ A

#### Diagnosis for Short Circuit

##### Judgment Value

Malfunction Criteria	Threshold Value
Time for reaching target current	$\leq 0.075$ ms

**Time Needed for Diagnosis:** TDC  $\times$  50 times

**Malfunction Indicator Light Illumination:** Illuminates as soon as a malfunction occurs.

## Diagnostic Trouble Code (DTC) Detecting Criteria

### GENERAL DESCRIPTION

---

#### **EQ:DTC P1262 DI INJECTOR CIRCUIT / OPEN - (CYLINDER 2)**

##### **1. OUTLINE OF DIAGNOSIS**

###### **NOTE:**

For the detection standard, refer to DTC P1261. <Ref. to GD(w/o STI)-171, DTC P1261 DI INJECTOR CIRCUIT / OPEN - (CYLINDER 1), Diagnostic Trouble Code (DTC) Detecting Criteria.>

#### **ER:DTC P1263 DI INJECTOR CIRCUIT / OPEN - (CYLINDER 3)**

##### **1. OUTLINE OF DIAGNOSIS**

###### **NOTE:**

For the detection standard, refer to DTC P1261. <Ref. to GD(w/o STI)-171, DTC P1261 DI INJECTOR CIRCUIT / OPEN - (CYLINDER 1), Diagnostic Trouble Code (DTC) Detecting Criteria.>

#### **ES:DTC P1264 DI INJECTOR CIRCUIT / OPEN - (CYLINDER 4)**

##### **1. OUTLINE OF DIAGNOSIS**

###### **NOTE:**

For the detection standard, refer to DTC P1261. <Ref. to GD(w/o STI)-171, DTC P1261 DI INJECTOR CIRCUIT / OPEN - (CYLINDER 1), Diagnostic Trouble Code (DTC) Detecting Criteria.>

# Diagnostic Trouble Code (DTC) Detecting Criteria

GENERAL DESCRIPTION

## ET:DTC P1449 EVAPORATIVE EMISSION CONT. SYS. AIR FILTER CLOG

### 1. OUTLINE OF DIAGNOSIS

Detect the drain filter clogging by the pressure change during purge introduction.

Judge as drain filter clogging malfunction if the pressure in the evaporative emission system piping suddenly decreases by the purging.

### 2. COMPONENT DESCRIPTION

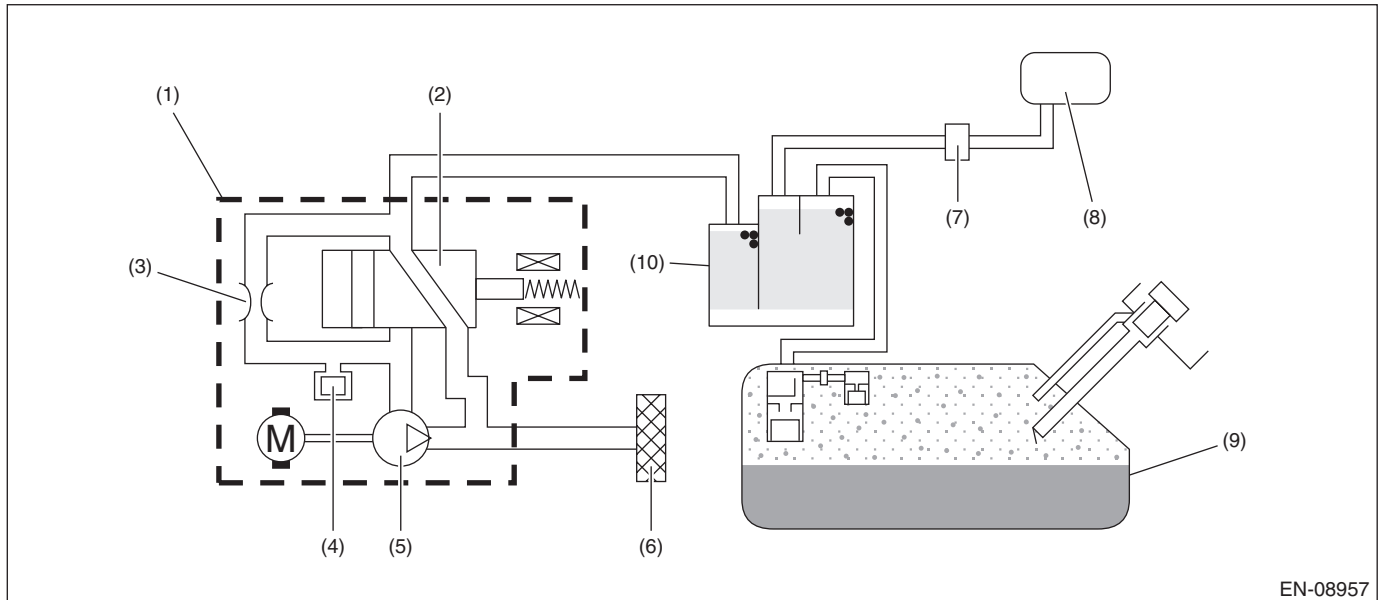

- |   |                                  |               |
|---|----------------------------------|---------------|
| (1) ELCM                                  | (5) Vacuum pump                  | (9) Fuel tank |
| (2) Switching valve                       | (6) Drain filter                 | (10) Canister |
| (3) Reference orifice (0.02 inch orifice) | (7) Purge control solenoid valve |               |
| (4) Pressure sensor                       | (8) Intake manifold              |               |

### 3. ENABLE CONDITIONS

Secondary Parameters	Enable Conditions
Battery voltage	≥ 10.9 V
Elapsed time after starting the engine	≥ 20000 ms
ELCM vacuum pump	Not in operation
ELCM switching valve	Open
Continuous time of following conditions	≥ 18.12 s
Pressure change in 40 ms	≤ 666.61 Pa (5 mmHg, 0.2 inHg)

### 4. GENERAL DRIVING CYCLE

Always perform the diagnosis continuously when purging is performed after 20000 ms have passed since the engine started.

# Diagnostic Trouble Code (DTC) Detecting Criteria

## GENERAL DESCRIPTION

### 5. DIAGNOSTIC METHOD

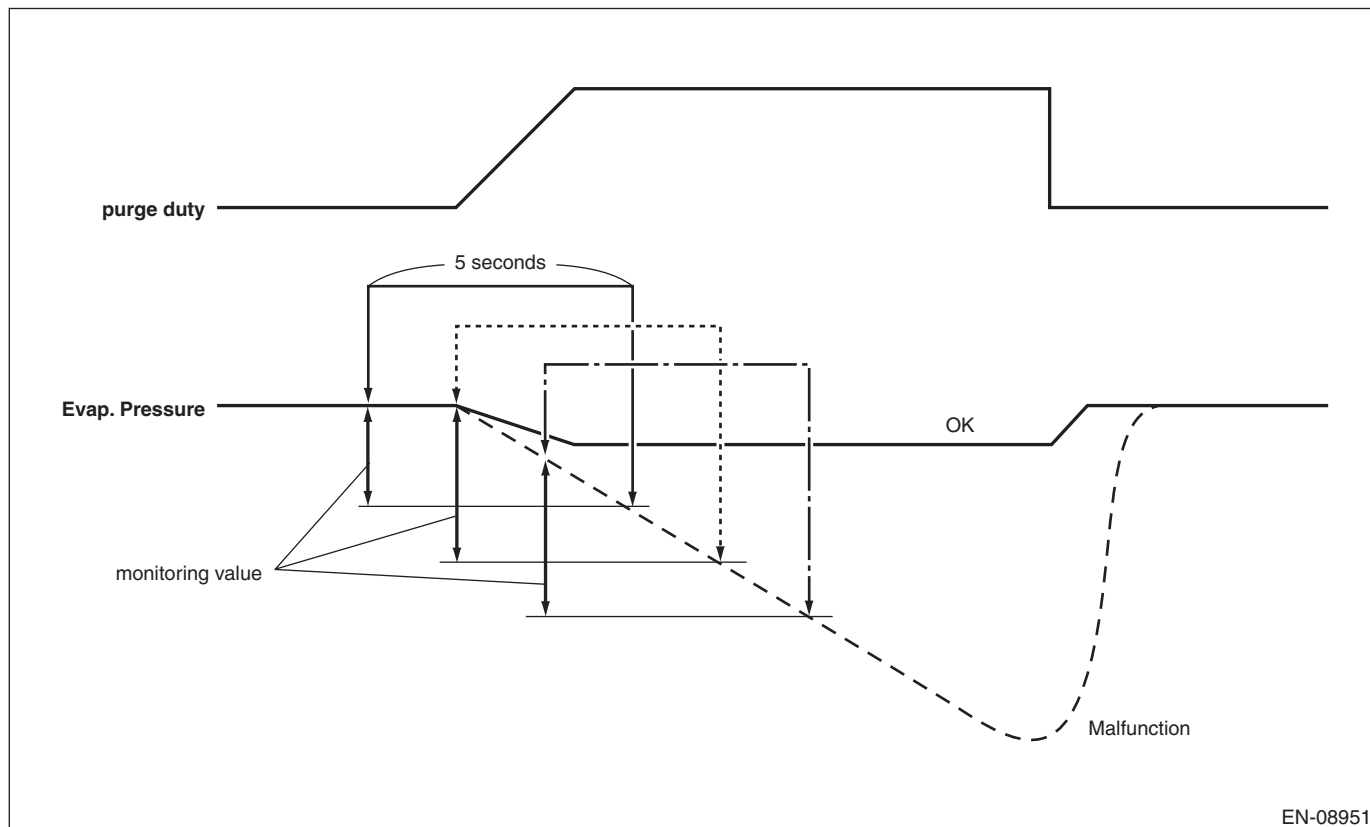

EN-08951

Calculate the difference between the ELCM pressure sensor output value as of 5 seconds ago and the current one, and if the value is greater than judgment value, detect and judge as filter clogging trouble. Judge as NG when the following conditions are established.

#### Judgment Value

Malfunction Criteria	Threshold Value
Pressure sensor output value as of 5 seconds ago – Current pressure sensor output value	> 1370 Pa (10.3 mmHg, 0.4 inHg)
Number of above conditions established	> 2 times

**Time Needed for Diagnosis:** 6 seconds

**Malfunction Indicator Light Illumination:** Illuminates when malfunction occurs in 2 continuous driving cycles.

## EU:DTC P1451 EVAPORATIVE EMISSION CONT. SYS.

### 1. OUTLINE OF DIAGNOSIS

NOTE:

For the detection standard, refer to DTC P0455. <Ref. to GD(w/o STI)-134, DTC P0455 EVAPORATIVE EMISSION SYSTEM LEAK DETECTED (LARGE LEAK), Diagnostic Trouble Code (DTC) Detecting Criteria.>

## EV:DTC P1458 CPC2 SOLENOID VALVE (CIRCUIT LOW)

### 1. OUTLINE OF DIAGNOSIS

Detect open or short circuit of the purge control solenoid valve 2.  
 Judge as NG when the ECM output level differs from the actual terminal level.

### 2. COMPONENT DESCRIPTION

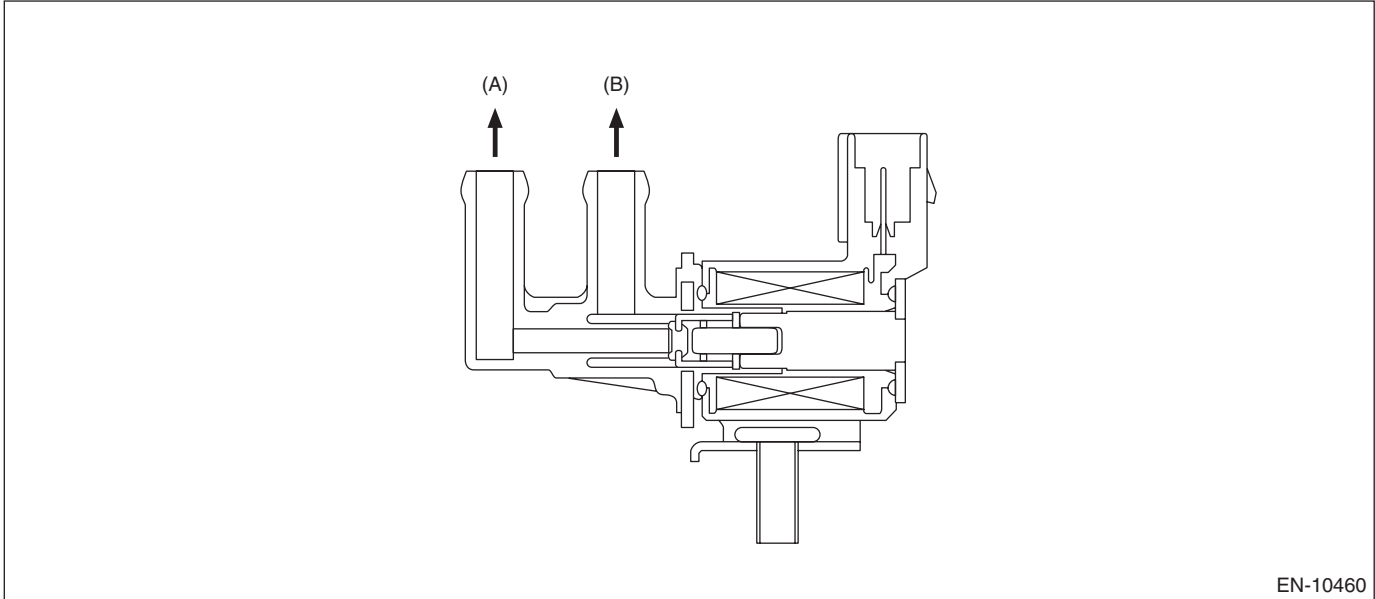

(A) To canister

(B) To intake manifold

### 3. ENABLE CONDITIONS

Secondary Parameters	Enable Conditions
Battery voltage	$\geq 10.9 \text{ V}$
Purge control solenoid valve 2 control signal	OFF

### 4. GENERAL DRIVING CYCLE

Always perform the diagnosis after starting the engine.

### 5. DIAGNOSTIC METHOD

If the duration of time while the following conditions are met is longer than the time indicated, judge as NG.

#### Judgment Value

Malfunction Criteria	Threshold Value
Output voltage	$\leq 2.2 \text{ V}$

**Time Needed for Diagnosis:** 2500 ms

**Malfunction Indicator Light Illumination:** Illuminates when malfunction occurs in 2 continuous driving cycles.

# Diagnostic Trouble Code (DTC) Detecting Criteria

## GENERAL DESCRIPTION

### EW:DTC P1459 CPC2 SOLENOID VALVE (CIRCUIT HIGH)

#### 1. OUTLINE OF DIAGNOSIS

Detect open or short circuit of the purge control solenoid valve 2.

Judge as NG when the ECM output level differs from the actual terminal level.

#### 2. COMPONENT DESCRIPTION

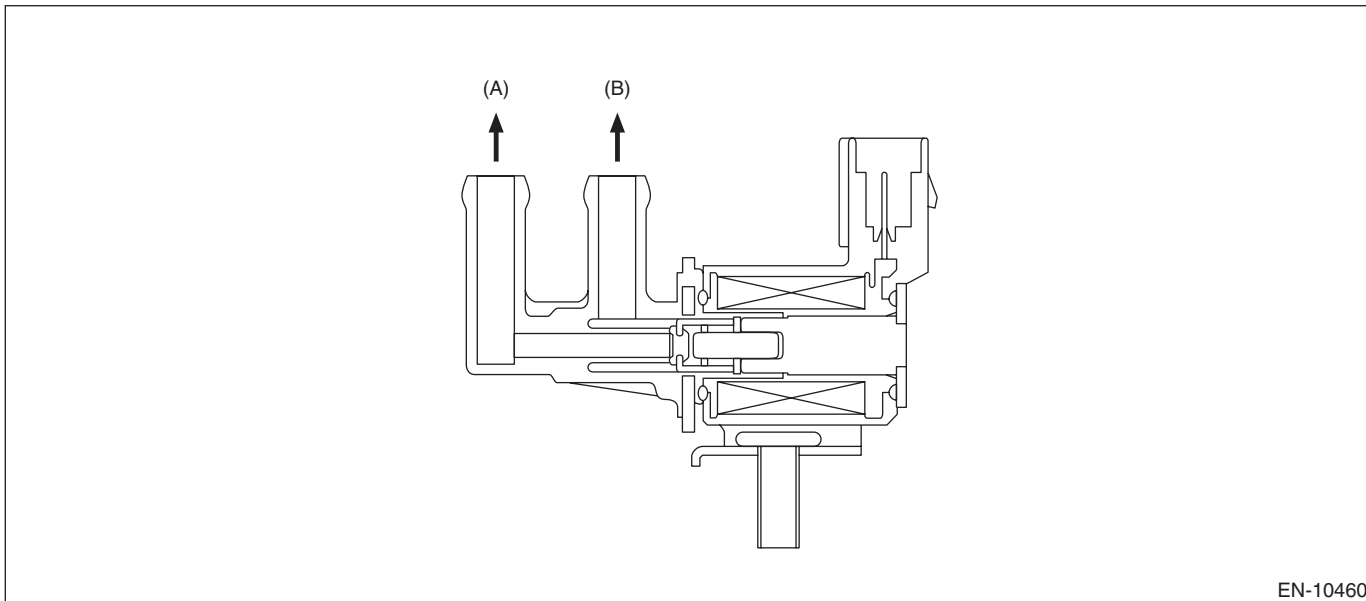

(A) To canister

(B) To intake manifold

#### 3. ENABLE CONDITIONS

Secondary Parameters	Enable Conditions
Battery voltage	$\geq 10.9$ V
Purge control solenoid 2 control signal	ON

#### 4. GENERAL DRIVING CYCLE

Always perform the diagnosis after starting the engine.

#### 5. DIAGNOSTIC METHOD

If the duration of time while the following conditions are met is longer than the time indicated, judge as NG.

##### Judgment Value

Malfunction Criteria	Threshold Value
Output current	$\geq 5$ A

**Time Needed for Diagnosis:** 2250 ms

**Malfunction Indicator Light Illumination:** Illuminates when malfunction occurs in 2 continuous driving cycles.

# Diagnostic Trouble Code (DTC) Detecting Criteria

GENERAL DESCRIPTION

## **EX:DTC P1492 EGR SOLENOID VALVE SIGNAL #1 CIRCUIT MALFUNCTION (LOW INPUT)**

### **1. OUTLINE OF DIAGNOSIS**

#### **NOTE:**

For the detection standard, refer to DTC P1498. <Ref. to GD(w/o STI)-178, DTC P1498 EGR SOLENOID VALVE SIGNAL #4 CIRCUIT MALFUNCTION (LOW INPUT), Diagnostic Trouble Code (DTC) Detecting Criteria.>

## **EY:DTC P1493 EGR SOLENOID VALVE SIGNAL #1 CIRCUIT MALFUNCTION (HIGH INPUT)**

### **1. OUTLINE OF DIAGNOSIS**

#### **NOTE:**

For the detection standard, refer to DTC P1499. <Ref. to GD(w/o STI)-179, DTC P1499 EGR SOLENOID VALVE SIGNAL #4 CIRCUIT MALFUNCTION (HIGH INPUT), Diagnostic Trouble Code (DTC) Detecting Criteria.>

## **EZ:DTC P1494 EGR SOLENOID VALVE SIGNAL #2 CIRCUIT MALFUNCTION (LOW INPUT)**

### **1. OUTLINE OF DIAGNOSIS**

#### **NOTE:**

For the detection standard, refer to DTC P1498. <Ref. to GD(w/o STI)-178, DTC P1498 EGR SOLENOID VALVE SIGNAL #4 CIRCUIT MALFUNCTION (LOW INPUT), Diagnostic Trouble Code (DTC) Detecting Criteria.>

## **FA:DTC P1495 EGR SOLENOID VALVE SIGNAL #2 CIRCUIT MALFUNCTION (HIGH INPUT)**

### **1. OUTLINE OF DIAGNOSIS**

#### **NOTE:**

For the detection standard, refer to DTC P1499. <Ref. to GD(w/o STI)-179, DTC P1499 EGR SOLENOID VALVE SIGNAL #4 CIRCUIT MALFUNCTION (HIGH INPUT), Diagnostic Trouble Code (DTC) Detecting Criteria.>

## **FB:DTC P1496 EGR SOLENOID VALVE SIGNAL #3 CIRCUIT MALFUNCTION (LOW INPUT)**

### **1. OUTLINE OF DIAGNOSIS**

#### **NOTE:**

For the detection standard, refer to DTC P1498. <Ref. to GD(w/o STI)-178, DTC P1498 EGR SOLENOID VALVE SIGNAL #4 CIRCUIT MALFUNCTION (LOW INPUT), Diagnostic Trouble Code (DTC) Detecting Criteria.>

## **FC:DTC P1497 EGR SOLENOID VALVE SIGNAL #3 CIRCUIT MALFUNCTION (HIGH INPUT)**

### **1. OUTLINE OF DIAGNOSIS**

#### **NOTE:**

For the detection standard, refer to DTC P1499. <Ref. to GD(w/o STI)-179, DTC P1499 EGR SOLENOID VALVE SIGNAL #4 CIRCUIT MALFUNCTION (HIGH INPUT), Diagnostic Trouble Code (DTC) Detecting Criteria.>

# Diagnostic Trouble Code (DTC) Detecting Criteria

## GENERAL DESCRIPTION

### FD:DTC P1498 EGR SOLENOID VALVE SIGNAL #4 CIRCUIT MALFUNCTION (LOW INPUT)

#### 1. OUTLINE OF DIAGNOSIS

- Detects open or short circuit of EGR.
- Judge as NG when the ECM output level differs from the actual terminal level.

#### 2. COMPONENT DESCRIPTION

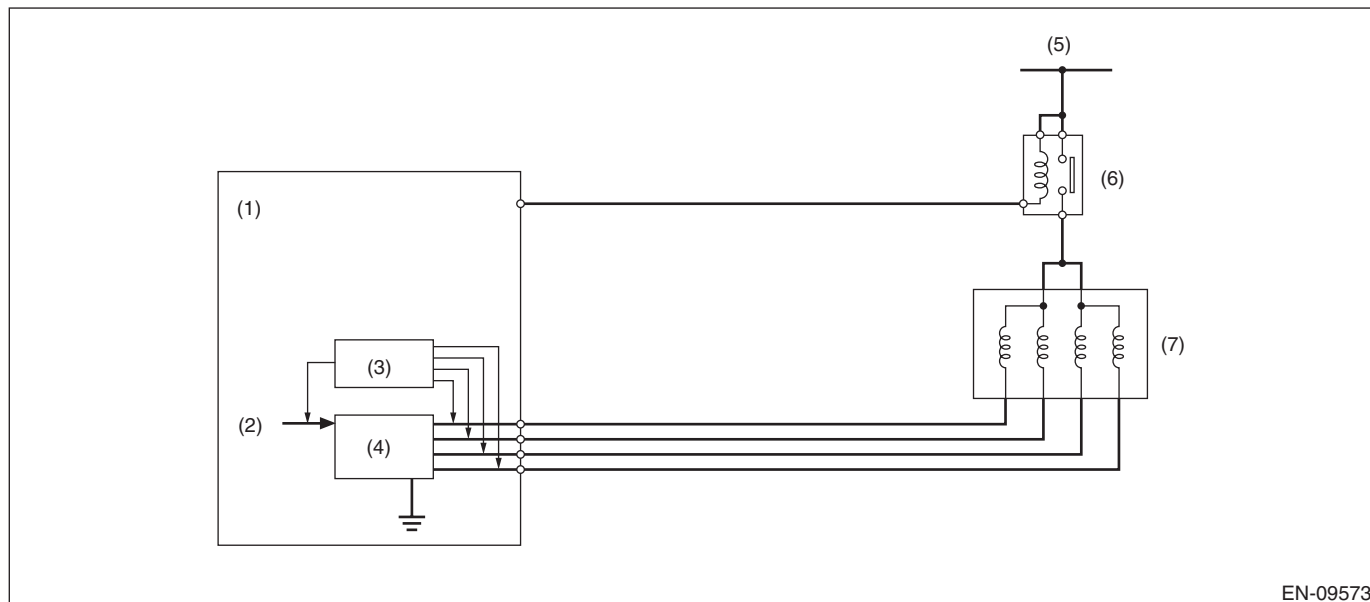

- |                                 |                     |                       |
|---------------------------------|---------------------|-----------------------|
| (1) Engine control module (ECM) | (4) Switch circuit  | (6) Main relay        |
| (2) Computer unit (CPU)         | (5) Battery voltage | (7) EGR control valve |
| (3) Detecting circuit           |                     |                       |

#### 3. ENABLE CONDITIONS

Secondary Parameters	Enable Conditions
EGR control signal	OFF
Battery voltage	$\geq 10.9 \text{ V}$
Elapsed time after starting the engine	$\geq 1 \text{ s}$

#### 4. GENERAL DRIVING CYCLE

Always perform the diagnosis continuously.

#### 5. DIAGNOSTIC METHOD

If the duration of time while the following conditions are met is longer than the time indicated, judge as NG.

##### Judgment Value

Malfunction Criteria	Threshold Value
Terminal voltage	$\leq 2.2 \text{ V}$

**Time Needed for Diagnosis:** 2500 ms

**Malfunction Indicator Light Illumination:** Illuminates as soon as a malfunction occurs.



## FE:DTC P1499 EGR SOLENOID VALVE SIGNAL #4 CIRCUIT MALFUNCTION (HIGH INPUT)

### 1. OUTLINE OF DIAGNOSIS

- Detects open or short circuit of EGR.
- Judge as NG when the ECM output level differs from the actual terminal level.

### 2. COMPONENT DESCRIPTION

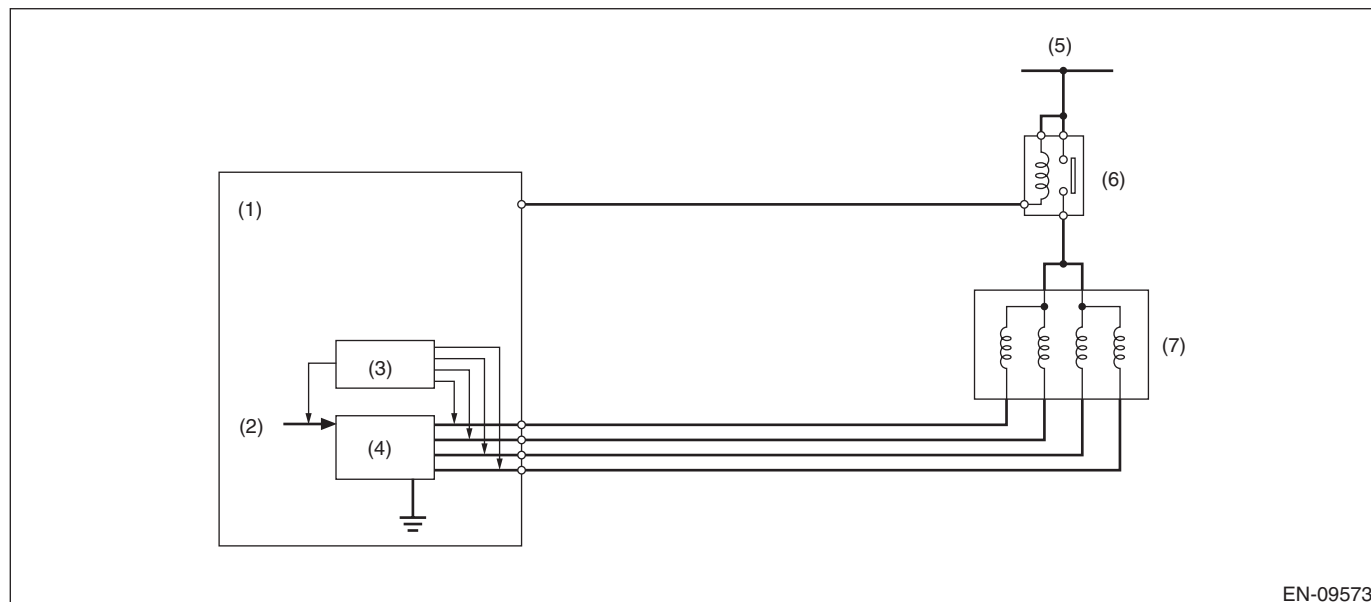

- |                                 |                     |                       |
|---------------------------------|---------------------|-----------------------|
| (1) Engine control module (ECM) | (4) Switch circuit  | (6) Main relay        |
| (2) Computer unit (CPU)         | (5) Battery voltage | (7) EGR control valve |
| (3) Detecting circuit           |                     |                       |

### 3. ENABLE CONDITIONS

Secondary Parameters	Enable Conditions
EGR control signal	ON
Battery voltage	≥ 10.9 V
Elapsed time after starting the engine	≥ 1 s

### 4. GENERAL DRIVING CYCLE

Always perform the diagnosis continuously.

### 5. DIAGNOSTIC METHOD

If the duration of time while the following conditions are met is longer than the time indicated, judge as NG.

#### Judgment Value

Malfunction Criteria	Threshold Value
Terminal current	≥ 5 A

**Time Needed for Diagnosis:** 2250 ms

**Malfunction Indicator Light Illumination:** Illuminates as soon as a malfunction occurs.

# Diagnostic Trouble Code (DTC) Detecting Criteria

## GENERAL DESCRIPTION

---

### FF:DTC P1603 ENGINE STALL HISTORY

#### 1. OUTLINE OF DIAGNOSIS

Judge as NG when the engine stops except by operating the ignition switch after starting the engine.

#### 2. ENABLE CONDITIONS

Secondary Parameters	Enable Conditions
Engine condition	After engine starting

#### 3. GENERAL DRIVING CYCLE

Always perform the diagnosis continuously after the enable conditions have been established.

#### 4. DIAGNOSTIC METHOD

If the duration of time while the following conditions are met is longer than the time indicated, judge as NG.

##### Judgment Value

Malfunction Criteria	Threshold Value
Engine speed	$\leq 300$ rpm

**Time Needed for Diagnosis:** 60 ms

**Malfunction Indicator Light Illumination:** Does not illuminate.

# Diagnostic Trouble Code (DTC) Detecting Criteria

GENERAL DESCRIPTION

## FG:DTC P1604 STARTABILITY MALFUNCTION

### 1. OUTLINE OF DIAGNOSIS

Judge as NG when the status enters into any one of the followings.

- Although starter signal input is present in ECM, the engine does not start (diagnosis 1)
- Although starter signal input is present in ECM, starting takes more time than it should (diagnosis 1)
- The engine stops immediately after starting except by operating the ignition switch (diagnosis 2)

### 2. ENABLE CONDITIONS

#### Diagnosis 1

Secondary Parameters	Enable Conditions
Starter signal	ON

#### Diagnosis 2

Secondary Parameters	Enable Conditions
Elapsed time after starting the engine	$\leq 2$ s

### 3. GENERAL DRIVING CYCLE

Always perform the diagnosis continuously after the enable conditions have been established.

### 4. DIAGNOSTIC METHOD

#### Diagnosis 1

If the duration of time while the following conditions are met is longer than the time indicated, judge as NG.

#### Judgment Value

Malfunction Criteria	Threshold Value
Engine speed	< 500 rpm

**Time Needed for Diagnosis:** 2 — 26 seconds

#### Diagnosis 2

Judge as NG when the following conditions are established.

#### Judgment Value

Malfunction Criteria	Threshold Value
Engine speed	< 300 rpm

**Time Needed for Diagnosis:** Less than 1 second

**Malfunction Indicator Light Illumination:** Does not illuminate.

# Diagnostic Trouble Code (DTC) Detecting Criteria

## GENERAL DESCRIPTION

---

### FH:DTC P1C00 BATTERY MONITOR MODULE "A"

#### 1. OUTLINE OF DIAGNOSIS

Judge as NG when faulty signal of each part is sent from the battery sensor.

#### 2. COMPONENT DESCRIPTION

The battery sensor monitors the data of battery voltage, current, temperature, etc. ECM receives these data via LIN communication with the battery sensor.

#### 3. ENABLE CONDITIONS

Secondary Parameters	Enable Conditions
Ignition switch	ON

#### 4. GENERAL DRIVING CYCLE

Always perform the diagnosis continuously after the enable conditions have been established.

#### 5. DIAGNOSTIC METHOD

Judge as NG when the following conditions are established.

##### Judgment Value

Malfunction Criteria	Threshold Value
Receives «Internal Error» or Receives «Temperature Sensor Error» or Receives «Voltage Sensor Error» or Receives «Current Sensor Error»	ON ON ON ON

**Time Needed for Diagnosis:** Less than 1 second

**Malfunction Indicator Light Illumination:** Does not illuminate.

# Diagnostic Trouble Code (DTC) Detecting Criteria

GENERAL DESCRIPTION

## FI: DTC P2004 INTAKE MANIFOLD RUNNER CONTROL STUCK OPEN (BANK 1)

### 1. OUTLINE OF DIAGNOSIS

Detect the malfunction of tumble generator valve motor function.

Judge open fixing malfunction when the opening degree is large even after finishing the tumble generator valve closing driving.

### 2. ENABLE CONDITIONS

Secondary Parameters	Enable Conditions
Battery voltage	$\geq 10.9$ V
Tumble generator valve "close" signal output time	$\geq 3.2$ s

### 3. GENERAL DRIVING CYCLE

Always perform the diagnosis continuously.

### 4. DIAGNOSTIC METHOD

If the duration of time while the following conditions are met is longer than the time indicated, judge as NG.

#### Judgment Value

Malfunction Criteria	Threshold Value
Tumble generator valve opening	$\geq 57$ deg

**Time Needed for Diagnosis:** 3000 ms

**Malfunction Indicator Light Illumination:** Illuminates as soon as a malfunction occurs.

# Diagnostic Trouble Code (DTC) Detecting Criteria

## GENERAL DESCRIPTION

---

### **FJ: DTC P2005 INTAKE MANIFOLD RUNNER CONTROL STUCK OPEN (BANK 2)**

#### **1. OUTLINE OF DIAGNOSIS**

Detect the malfunction of tumble generator valve motor function.

Judge open fixing malfunction when the opening degree is large even after finishing the tumble generator valve closing driving.

#### **2. ENABLE CONDITIONS**

Secondary Parameters	Enable Conditions
Battery voltage	≥ 10.9 V
Tumble generator valve "close" signal output time	≥ 3.2 s

#### **3. GENERAL DRIVING CYCLE**

Always perform the diagnosis continuously.

#### **4. DIAGNOSTIC METHOD**

If the duration of time while the following conditions are met is longer than the time indicated, judge as NG.

##### **Judgment Value**

Malfunction Criteria	Threshold Value
Tumble generator valve opening	≥ 57 deg

**Time Needed for Diagnosis:** 3000 ms

**Malfunction Indicator Light Illumination:** Illuminates as soon as a malfunction occurs.

# Diagnostic Trouble Code (DTC) Detecting Criteria

GENERAL DESCRIPTION

## FK:DTC P2006 INTAKE MANIFOLD RUNNER CONTROL STUCK CLOSED (BANK 1)

### 1. OUTLINE OF DIAGNOSIS

Detect the malfunction of tumble generator valve motor function.

Judge close fixing malfunction when the opening degree is small even after finishing the tumble generator valve open driving.

### 2. ENABLE CONDITIONS

Secondary Parameters	Enable Conditions
Battery voltage	$\geq 10.9$ V
Tumble generator valve "open" signal output time	$\geq 4.6$ s

### 3. GENERAL DRIVING CYCLE

Always perform the diagnosis continuously.

### 4. DIAGNOSTIC METHOD

If the duration of time while the following conditions are met is longer than the time indicated, judge as NG.

#### Judgment Value

Malfunction Criteria	Threshold Value
Tumble generator valve opening	$< 57$ deg

**Time Needed for Diagnosis:** 3000 ms

**Malfunction Indicator Light Illumination:** Illuminates as soon as a malfunction occurs.

# Diagnostic Trouble Code (DTC) Detecting Criteria

## GENERAL DESCRIPTION

---

### FL:DTC P2007 INTAKE MANIFOLD RUNNER CONTROL STUCK CLOSED (BANK 2)

#### 1. OUTLINE OF DIAGNOSIS

Detect the malfunction of tumble generator valve motor function.

Judge close fixing malfunction when the opening degree is small even after finishing the tumble generator valve open driving.

#### 2. ENABLE CONDITIONS

Secondary Parameters	Enable Conditions
Battery voltage	$\geq 10.9$ V
Tumble generator valve "open" signal output time	$\geq 4.6$ s

#### 3. GENERAL DRIVING CYCLE

Always perform the diagnosis continuously.

#### 4. DIAGNOSTIC METHOD

If the duration of time while the following conditions are met is longer than the time indicated, judge as NG.

##### Judgment Value

Malfunction Criteria	Threshold Value
Tumble generator valve opening	$< 57$ deg

**Time Needed for Diagnosis:** 3000 ms

**Malfunction Indicator Light Illumination:** Illuminates as soon as a malfunction occurs.



# Diagnostic Trouble Code (DTC) Detecting Criteria

GENERAL DESCRIPTION

## FM:DTC P2009 INTAKE MANIFOLD RUNNER CONTROL CIRCUIT LOW (BANK 1)

### 1. OUTLINE OF DIAGNOSIS

Detect the open or short circuit of tumble generator valve motor.

Judge as NG when the overcurrent signal is sent from IC after tumble generator valve driving IC diagnosis.

### 2. COMPONENT DESCRIPTION

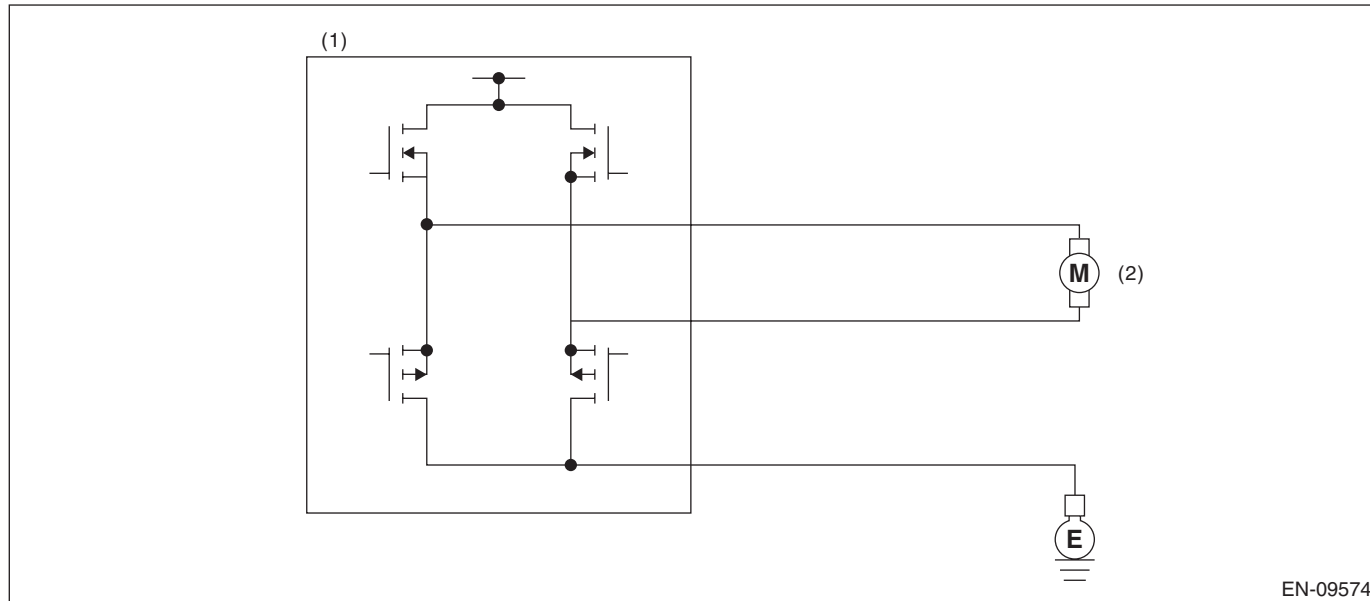

(1) Engine control module (ECM)

(2) Tumble generator valve

### 3. ENABLE CONDITIONS

Secondary Parameters	Enable Conditions
Battery voltage	≥ 10.9 V
Tumble generator valve drive signal	Open or Closed

### 4. GENERAL DRIVING CYCLE

Always perform the diagnosis continuously.

### 5. DIAGNOSTIC METHOD

If the duration of time while the following conditions are met is longer than the time indicated, judge as NG.

#### Judgment Value

Malfunction Criteria	Threshold Value
Overcurrent signal from tumble generator valve drive IC	ON

**Time Needed for Diagnosis:** 320 ms

**Malfunction Indicator Light Illumination:** Illuminates as soon as a malfunction occurs.

# Diagnostic Trouble Code (DTC) Detecting Criteria

## GENERAL DESCRIPTION

### FN:DTC P2012 INTAKE MANIFOLD RUNNER CONTROL CIRCUIT LOW (BANK 2)

#### 1. OUTLINE OF DIAGNOSIS

Detect the open or short circuit of tumble generator valve motor.

Judge as NG when the overcurrent signal is sent from IC after tumble generator valve driving IC diagnosis.

#### 2. COMPONENT DESCRIPTION

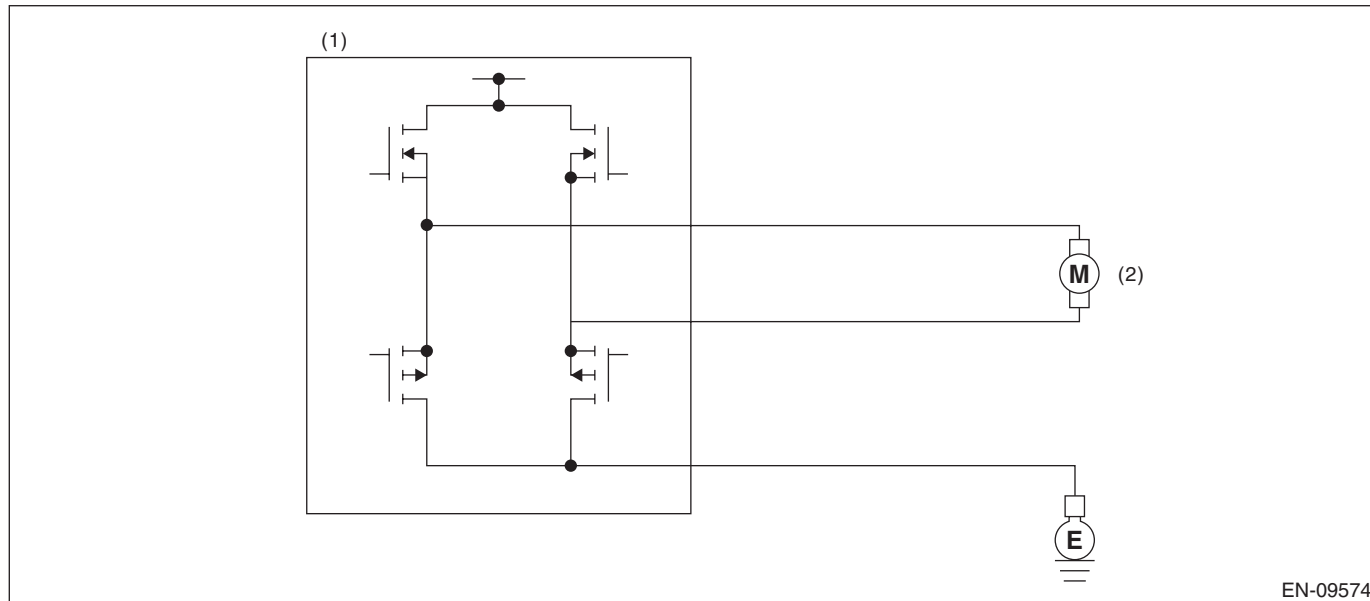

(1) Engine control module (ECM)      (2) Tumble generator valve

#### 3. ENABLE CONDITIONS

Secondary Parameters	Enable Conditions
Battery voltage	≥ 10.9 V
Tumble generator valve drive signal	Open or Closed

#### 4. GENERAL DRIVING CYCLE

Always perform the diagnosis continuously.

#### 5. DIAGNOSTIC METHOD

If the duration of time while the following conditions are met is longer than the time indicated, judge as NG.

##### Judgment Value

Malfunction Criteria	Threshold Value
Overcurrent signal from tumble generator valve drive IC	ON

**Time Needed for Diagnosis:** 320 ms

**Malfunction Indicator Light Illumination:** Illuminates as soon as a malfunction occurs.

# Diagnostic Trouble Code (DTC) Detecting Criteria

GENERAL DESCRIPTION

## FO:DTC P2016 TUMBLE GENERATED VALVE POSITION SENSOR 1 CIRCUIT LOW

### 1. OUTLINE OF DIAGNOSIS

Detect open or short circuit of tumble generator valve position sensor.  
Judge as NG if out of specification.

### 2. COMPONENT DESCRIPTION

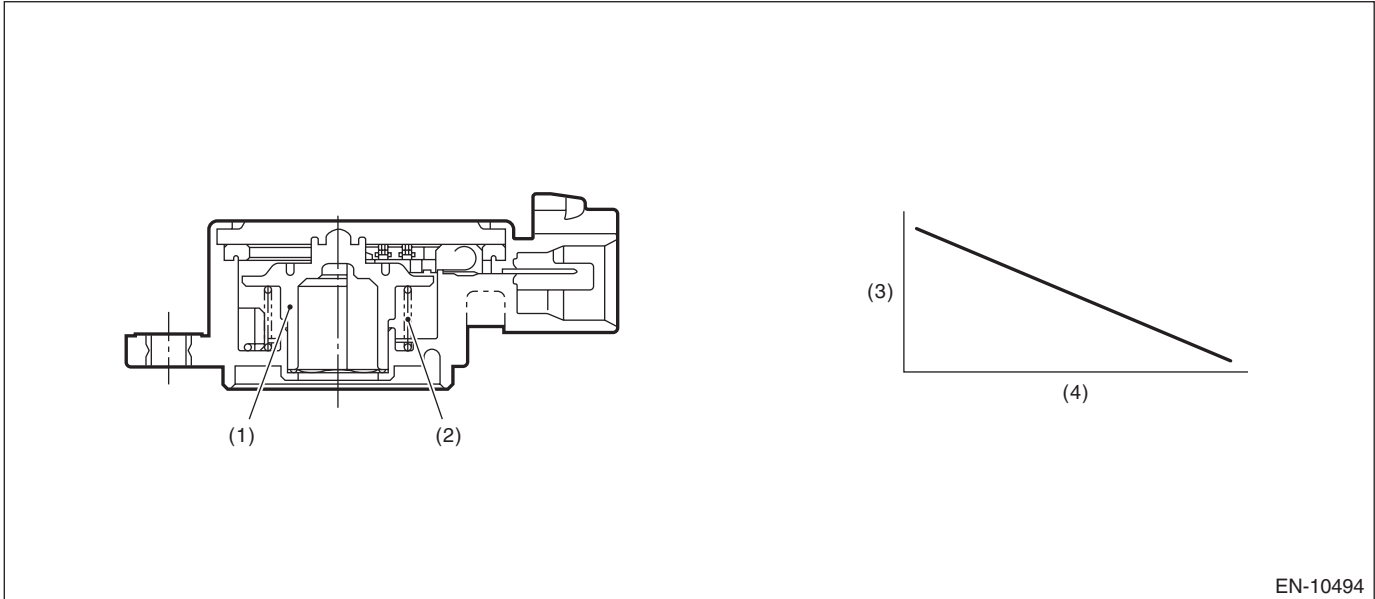

EN-10494

(1) Rotor

(3) Voltage (V)

(4) Tumble generator valve opening (°)

(2) Return spring

### 3. ENABLE CONDITIONS

Secondary Parameters	Enable Conditions
None	

### 4. GENERAL DRIVING CYCLE

Always perform the diagnosis continuously.

### 5. DIAGNOSTIC METHOD

If the duration of time while the following conditions are met is longer than the time indicated, judge as NG.

#### Judgment Value

Malfunction Criteria	Threshold Value
Output voltage	< 0.21 V

**Time Needed for Diagnosis:** 520 ms

**Malfunction Indicator Light Illumination:** Illuminates as soon as a malfunction occurs.

# Diagnostic Trouble Code (DTC) Detecting Criteria

## GENERAL DESCRIPTION

### FP:DTC P2017 TUMBLE GENERATED VALVE POSITION SENSOR 1 CIRCUIT HIGH

#### 1. OUTLINE OF DIAGNOSIS

Detect open or short circuit of tumble generator valve position sensor.  
Judge as NG if out of specification.

#### 2. COMPONENT DESCRIPTION

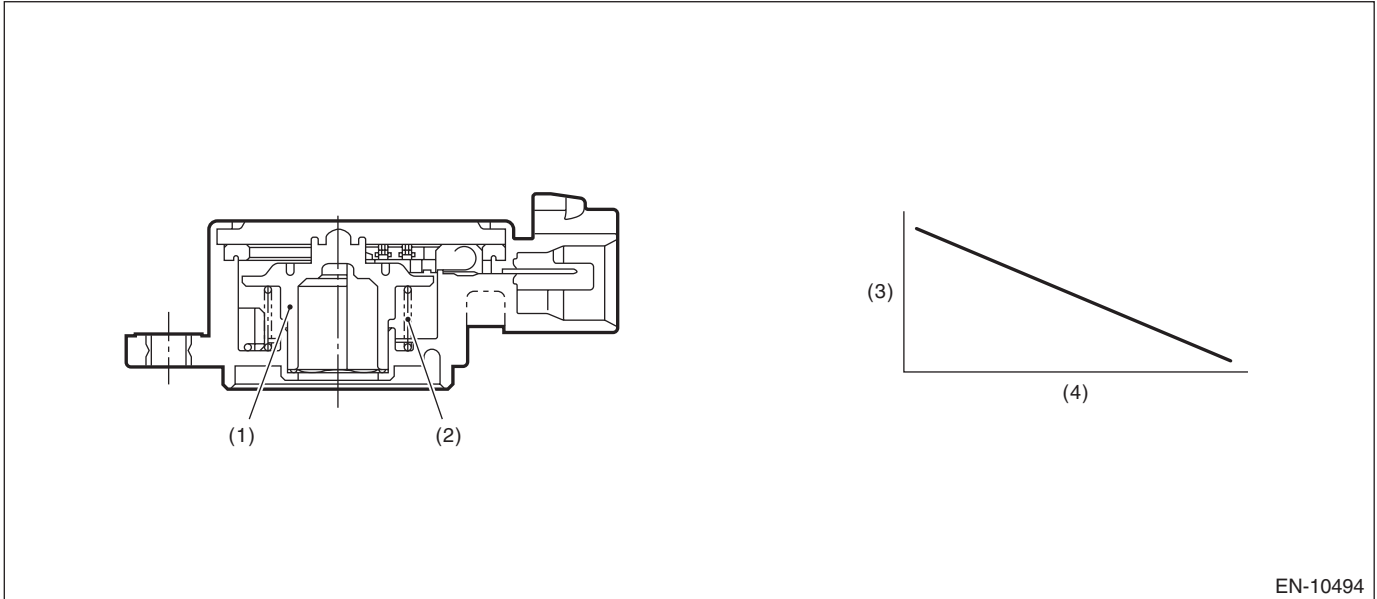

(1) Rotor

(3) Voltage (V)

(4) Tumble generator valve opening (°)

(2) Return spring

#### 3. ENABLE CONDITIONS

Secondary Parameters	Enable Conditions
None	

#### 4. GENERAL DRIVING CYCLE

Always perform the diagnosis continuously.

#### 5. DIAGNOSTIC METHOD

If the duration of time while the following conditions are met is longer than the time indicated, judge as NG.

##### Judgment Value

Malfunction Criteria	Threshold Value
Output voltage	> 4.47 V

**Time Needed for Diagnosis:** 520 ms

**Malfunction Indicator Light Illumination:** Illuminates as soon as a malfunction occurs.

# Diagnostic Trouble Code (DTC) Detecting Criteria

GENERAL DESCRIPTION

## FQ:DTC P2021 TUMBLE GENERATED VALVE POSITION SENSOR 2 CIRCUIT LOW

### 1. OUTLINE OF DIAGNOSIS

Detect open or short circuit of tumble generator valve position sensor.  
Judge as NG if out of specification.

### 2. COMPONENT DESCRIPTION

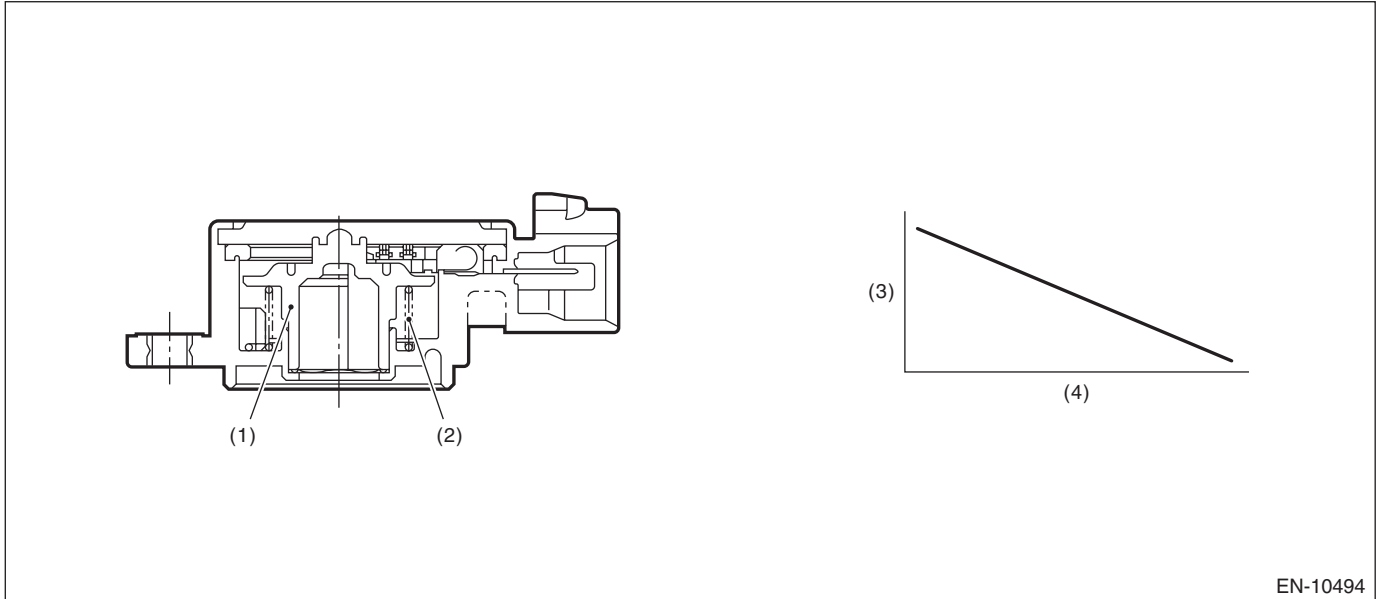

(1) Rotor

(3) Voltage (V)

(4) Tumble generator valve opening (°)

(2) Return spring

### 3. ENABLE CONDITIONS

Secondary Parameters	Enable Conditions
None	

### 4. GENERAL DRIVING CYCLE

Always perform the diagnosis continuously.

### 5. DIAGNOSTIC METHOD

If the duration of time while the following conditions are met is longer than the time indicated, judge as NG.

#### Judgment Value

Malfunction Criteria	Threshold Value
Output voltage	< 0.21 V

**Time Needed for Diagnosis:** 520 ms

**Malfunction Indicator Light Illumination:** Illuminates as soon as a malfunction occurs.

# Diagnostic Trouble Code (DTC) Detecting Criteria

## GENERAL DESCRIPTION

### FR:DTC P2022 TUMBLE GENERATED VALVE POSITION SENSOR 2 CIRCUIT HIGH

#### 1. OUTLINE OF DIAGNOSIS

Detect open or short circuit of tumble generator valve position sensor.  
Judge as NG if out of specification.

#### 2. COMPONENT DESCRIPTION

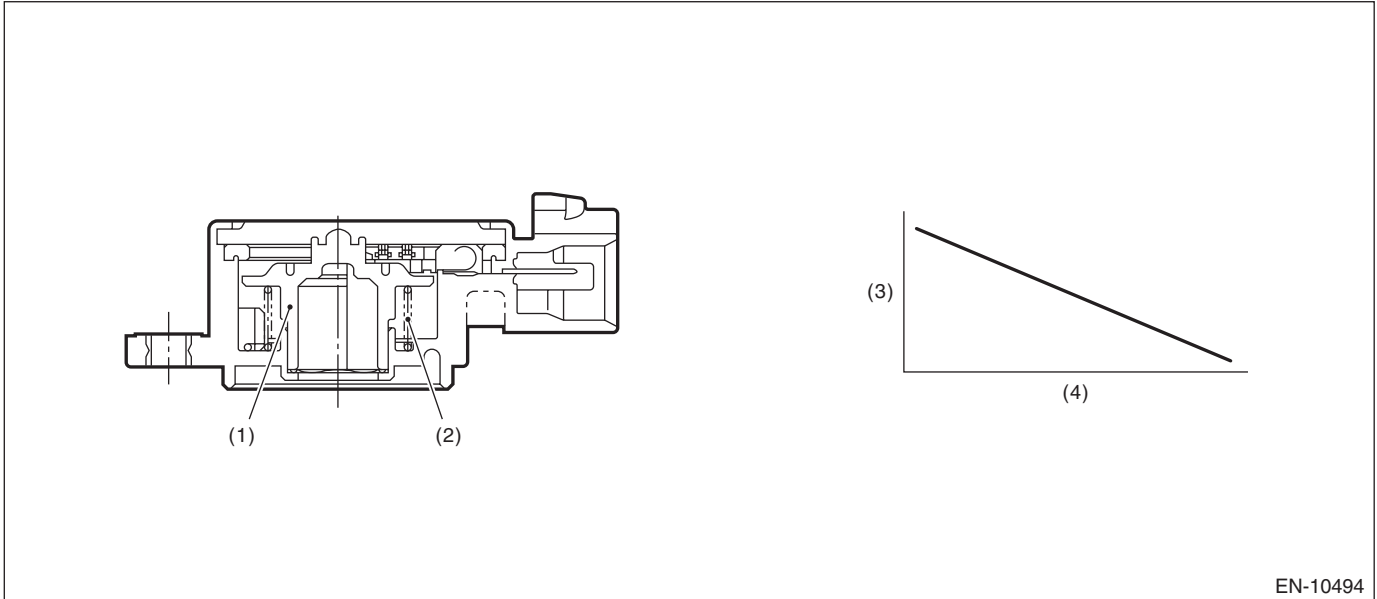

(1) Rotor

(3) Voltage (V)

(4) Tumble generator valve opening (°)

(2) Return spring

#### 3. ENABLE CONDITIONS

Secondary Parameters	Enable Conditions
None	

#### 4. GENERAL DRIVING CYCLE

Always perform the diagnosis continuously.

#### 5. DIAGNOSTIC METHOD

If the duration of time while the following conditions are met is longer than the time indicated, judge as NG.

##### Judgment Value

Malfunction Criteria	Threshold Value
Output voltage	> 4.47 V

**Time Needed for Diagnosis:** 520 ms

**Malfunction Indicator Light Illumination:** Illuminates as soon as a malfunction occurs.

# Diagnostic Trouble Code (DTC) Detecting Criteria

GENERAL DESCRIPTION

## FS:DTC P2096 POST CATALYST FUEL TRIM SYSTEM TOO LEAN (BANK 1)

### 1. OUTLINE OF DIAGNOSIS

Detect the malfunction of fuel system from the size of the sub feedback learning value.  
Control the sub feedback learning and judge as NG when the learning value is in the lean zone.

### 2. COMPONENT DESCRIPTION

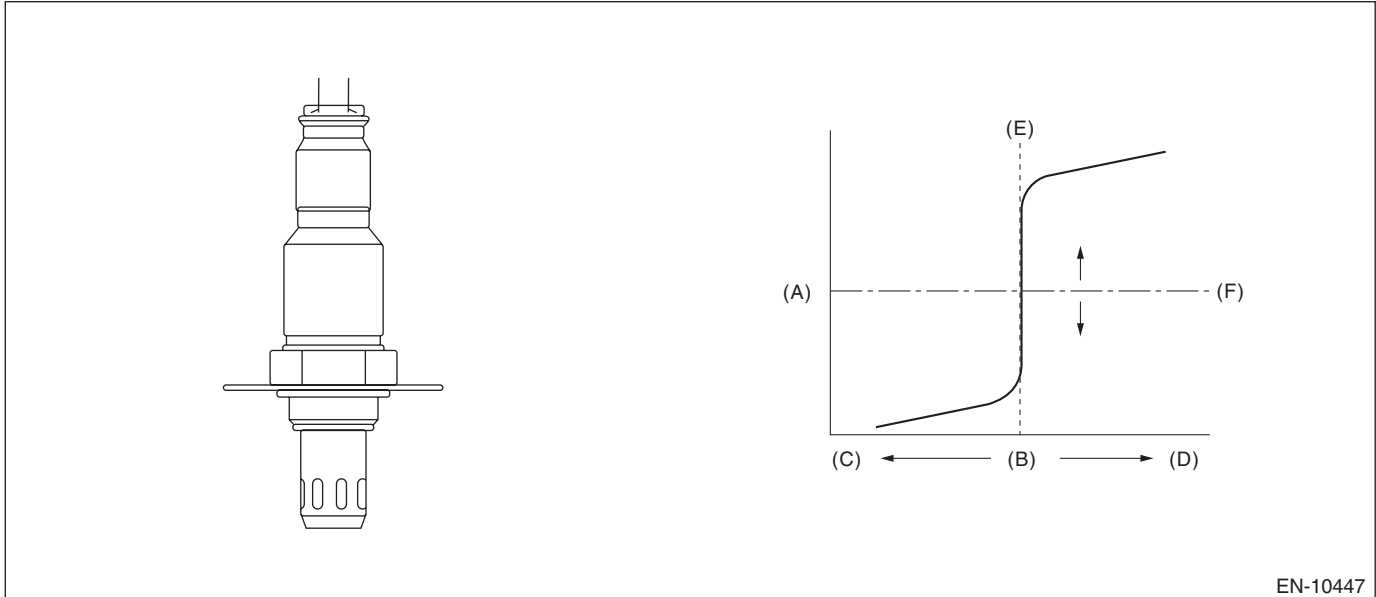

EN-10447

- |                         |                                |                         |
|-------------------------|--------------------------------|-------------------------|
| (A) Electromotive force | (B) Air fuel ratio             | (C) Lean                |
| (D) Rich                | (E) Theoretical air fuel ratio | (F) Comparative voltage |

### 3. ENABLE CONDITIONS

Secondary Parameters	Enable Conditions
Sub feedback	In operation

### 4. GENERAL DRIVING CYCLE

Perform the diagnosis continuously during sub feedback operation.

### 5. DIAGNOSTIC METHOD

If the duration of time while the following conditions are met is longer than the time indicated, judge as NG.

#### Judgment Value

Malfunction Criteria	Threshold Value
Sub feedback learning value	$\leq -0.073$

**Time Needed for Diagnosis:** 1 second

**Malfunction Indicator Light Illumination:** Illuminates when malfunction occurs in 2 continuous driving cycles.

# Diagnostic Trouble Code (DTC) Detecting Criteria

## GENERAL DESCRIPTION

### FT:DTC P2097 POST CATALYST FUEL TRIM SYSTEM TOO RICH (BANK 1)

#### 1. OUTLINE OF DIAGNOSIS

Detect the malfunction of fuel system from the size of the sub feedback learning value.

Sub feedback learning is being performed. When the learning value goes to the rich side, judge as NG.

#### 2. COMPONENT DESCRIPTION

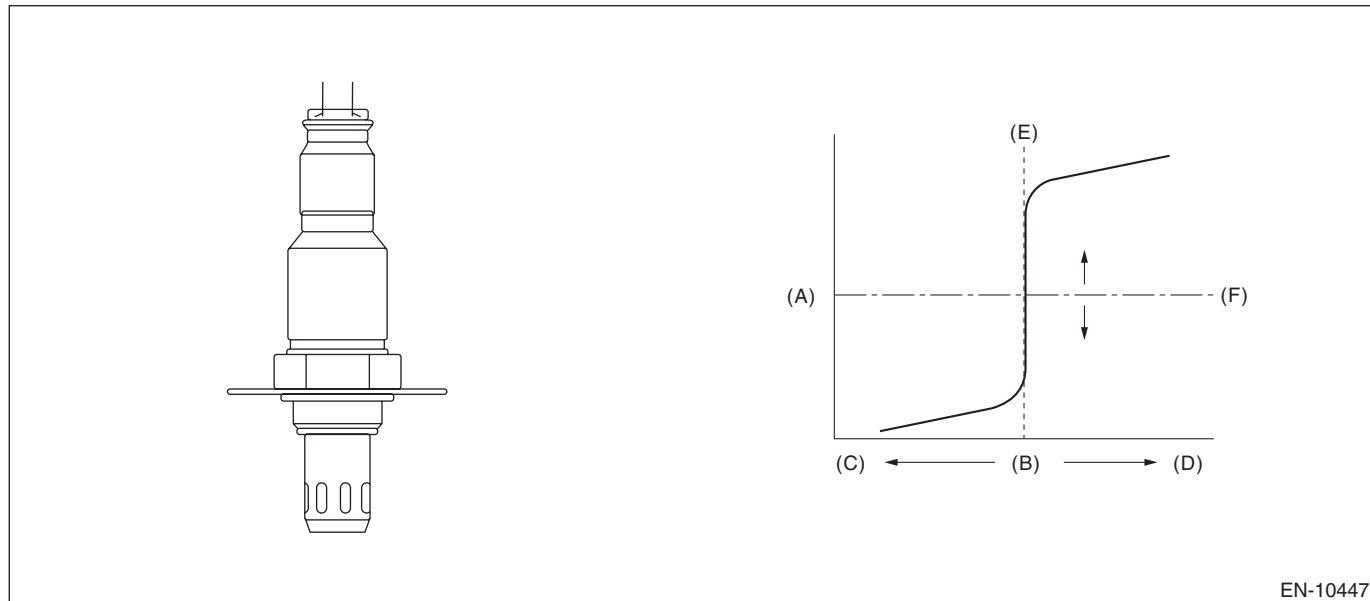

EN-10447

(A) Electromotive force

(B) Air fuel ratio

(C) Lean

(D) Rich

(E) Theoretical air fuel ratio

(F) Comparative voltage

#### 3. ENABLE CONDITIONS

Secondary Parameters	Enable Conditions
Sub feedback	In operation

#### 4. GENERAL DRIVING CYCLE

Perform the diagnosis continuously during sub feedback operation.

#### 5. DIAGNOSTIC METHOD

If the duration of time while the following conditions are met is longer than the time indicated, judge as NG.

##### Judgment Value

Malfunction Criteria	Threshold Value
Sub feedback learning value	$\geq 0.024$

**Time Needed for Diagnosis:** 1 second

**Malfunction Indicator Light Illumination:** Illuminates when malfunction occurs in 2 continuous driving cycles.



# Diagnostic Trouble Code (DTC) Detecting Criteria

GENERAL DESCRIPTION

## FU:DTC P2101 THROTTLE ACTUATOR CONTROL MOTOR CIRCUIT RANGE/ PERFORMANCE

### 1. OUTLINE OF DIAGNOSIS

In the diagnosis with ignition switch ON, judge as NG when the opening angle with the throttle driven to close direction is out of the specified range.

### 2. COMPONENT DESCRIPTION

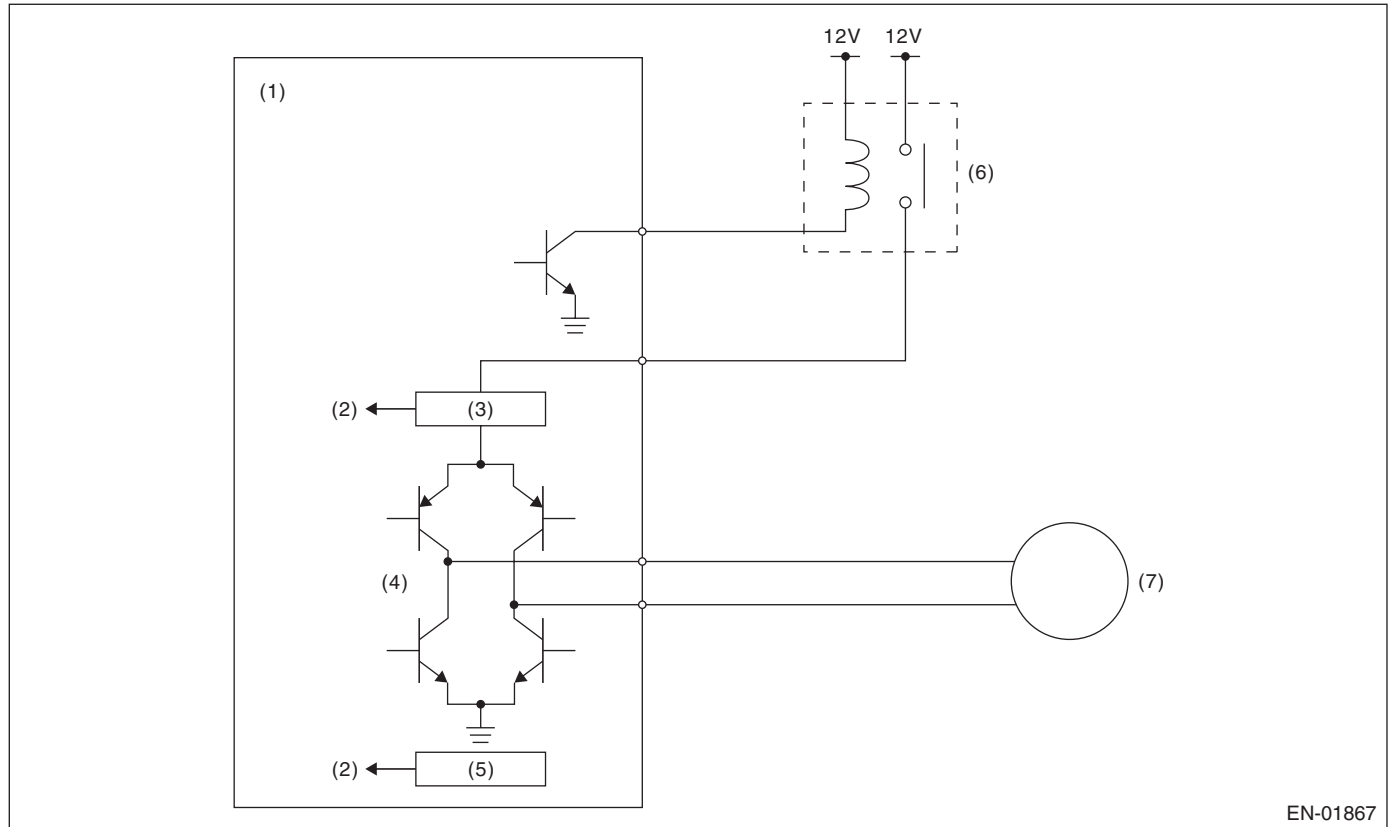

EN-01867

- |                                   |                                   |                                       |
|-----------------------------------|-----------------------------------|---------------------------------------|
| (1) Engine control module (ECM)   | (4) Drive circuit                 | (6) Electronic throttle control relay |
| (2) Detecting circuit             | (5) Temperature detection circuit | (7) Motor                             |
| (3) Overcurrent detection circuit |                                   |                                       |

### 3. ENABLE CONDITIONS

Secondary Parameters	Enable Conditions
Battery voltage	$\geq 6 \text{ V}$

### 4. GENERAL DRIVING CYCLE

Perform the diagnosis when the ignition switch is turned from OFF to ON.

### 5. DIAGNOSTIC METHOD

If the duration of time while the following conditions are met is longer than the time indicated, judge as NG.

#### Judgment Value

Malfunction Criteria	Threshold Value
Throttle opening angle during throttle minimum stop position learning	$\geq 36\%$

**Time Needed for Diagnosis:** 190 ms

**Malfunction Indicator Light Illumination:** Illuminates as soon as a malfunction occurs.

# Diagnostic Trouble Code (DTC) Detecting Criteria

## GENERAL DESCRIPTION

### FV:DTC P2102 THROTTLE ACTUATOR CONTROL MOTOR CIRCUIT LOW

#### 1. OUTLINE OF DIAGNOSIS

Judge as NG when the electronic throttle control power is not supplied even when ECM sets the electric control throttle relay to ON, or when the monitored electronic throttle control relay does not switch to OFF even when ECM sets the electronic throttle control relay to OFF.

#### 2. COMPONENT DESCRIPTION

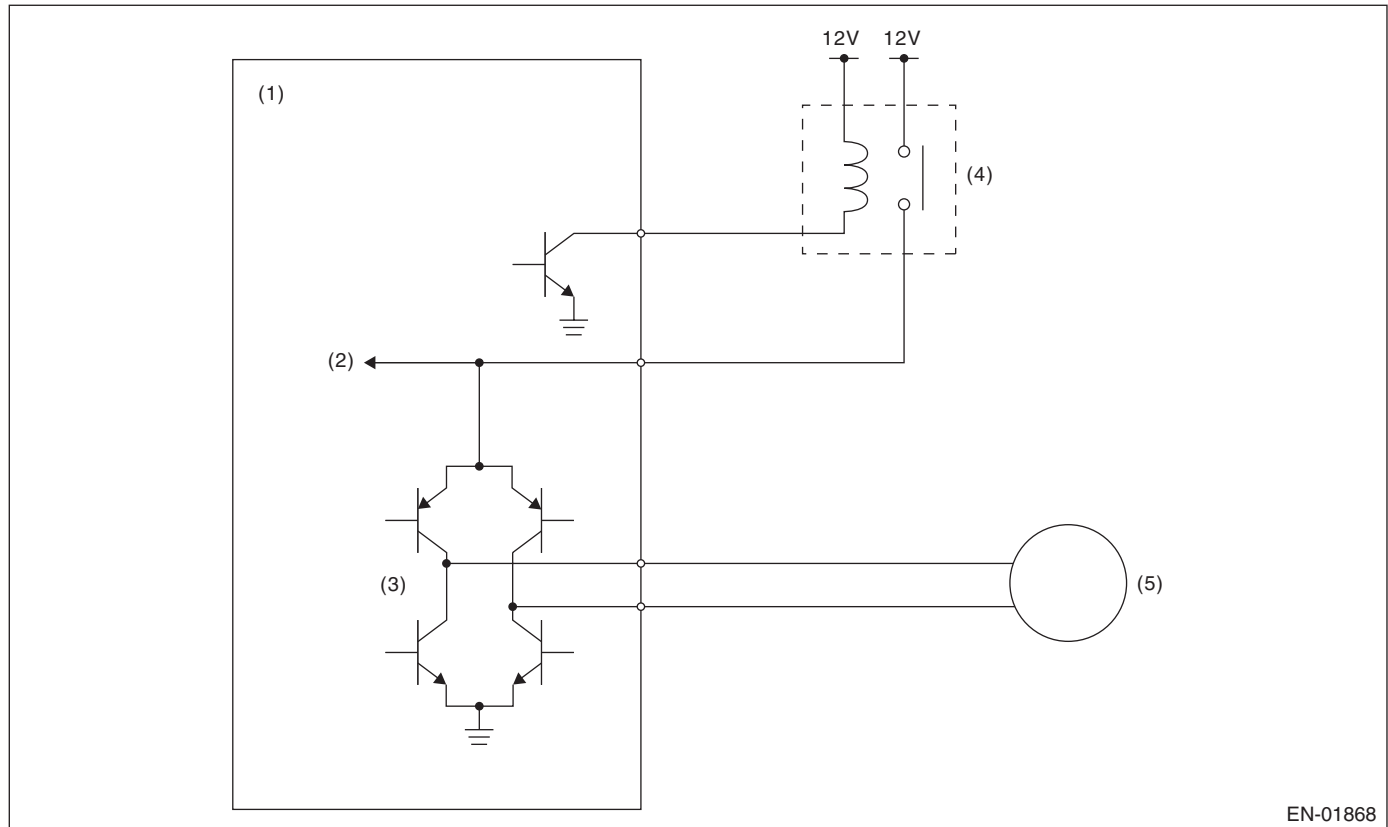

EN-01868

- (1) Engine control module (ECM)      (3) Drive circuit      (5) Motor  
 (2) Voltage detection circuit      (4) Electronic throttle control relay

#### 3. ENABLE CONDITIONS

Secondary Parameters	Enable Conditions
<For electronic throttle control power supply>	
Battery voltage	≥ 6 V
Electronic throttle control relay output	ON
<For electronic throttle control relay monitor>	
Battery voltage	≥ 10.9 V
Electronic throttle control relay output	OFF

#### 4. GENERAL DRIVING CYCLE

Always perform the diagnosis continuously.

# Diagnostic Trouble Code (DTC) Detecting Criteria

GENERAL DESCRIPTION

## 5. DIAGNOSTIC METHOD

If the duration of time while the following conditions are met is longer than the time indicated, judge as NG.

### Judgment Value

Malfunction Criteria	Threshold Value
<For electronic throttle control power supply> Electronic throttle control power voltage	< 6 V
<For electronic throttle control relay monitor> Electronic throttle control relay monitor voltage	≤ 1.5 V

**Time Needed for Diagnosis:** 510 ms

**Malfunction Indicator Light Illumination:** Illuminates as soon as a malfunction occurs.

# Diagnostic Trouble Code (DTC) Detecting Criteria

## GENERAL DESCRIPTION

### FW:DTC P2103 THROTTLE ACTUATOR CONTROL MOTOR CIRCUIT HIGH

#### 1. OUTLINE OF DIAGNOSIS

Judge as NG when the monitored electronic throttle control relay does not switch to ON even when ECM sets the electric control throttle relay to ON.

#### 2. COMPONENT DESCRIPTION

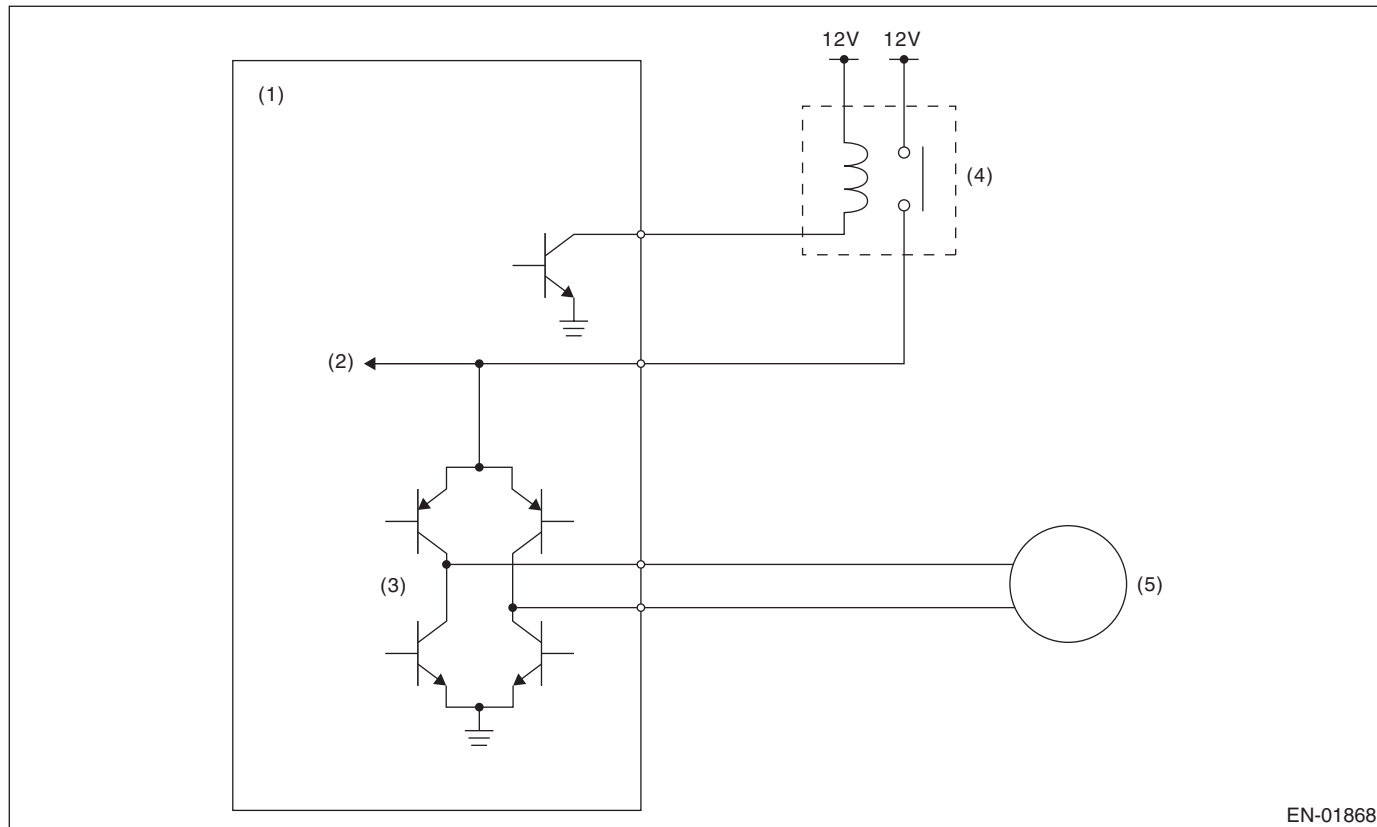

EN-01868

- (1) Engine control module (ECM)      (3) Drive circuit      (5) Motor  
 (2) Voltage detection circuit      (4) Electronic throttle control relay

#### 3. ENABLE CONDITIONS

Secondary Parameters	Enable Conditions
Battery voltage	$\geq 10.9 \text{ V}$
Electronic throttle control relay output	ON

#### 4. GENERAL DRIVING CYCLE

Always perform the diagnosis continuously.

#### 5. DIAGNOSTIC METHOD

If the duration of time while the following conditions are met is longer than the time indicated, judge as NG.

##### Judgment Value

Malfunction Criteria	Threshold Value
Electronic throttle control relay monitor voltage	$\geq 6 \text{ V}$

**Time Needed for Diagnosis:** 510 ms

**Malfunction Indicator Light Illumination:** Illuminates as soon as a malfunction occurs.

# Diagnostic Trouble Code (DTC) Detecting Criteria

GENERAL DESCRIPTION

## FX:DTC P2109 THROTTLE/PEDAL POSITION SENSOR “A” MINIMUM STOP PERFORMANCE

### 1. OUTLINE OF DIAGNOSIS

Judge as NG when full close point learning cannot be conducted or an abnormal value is detected.

### 2. COMPONENT DESCRIPTION

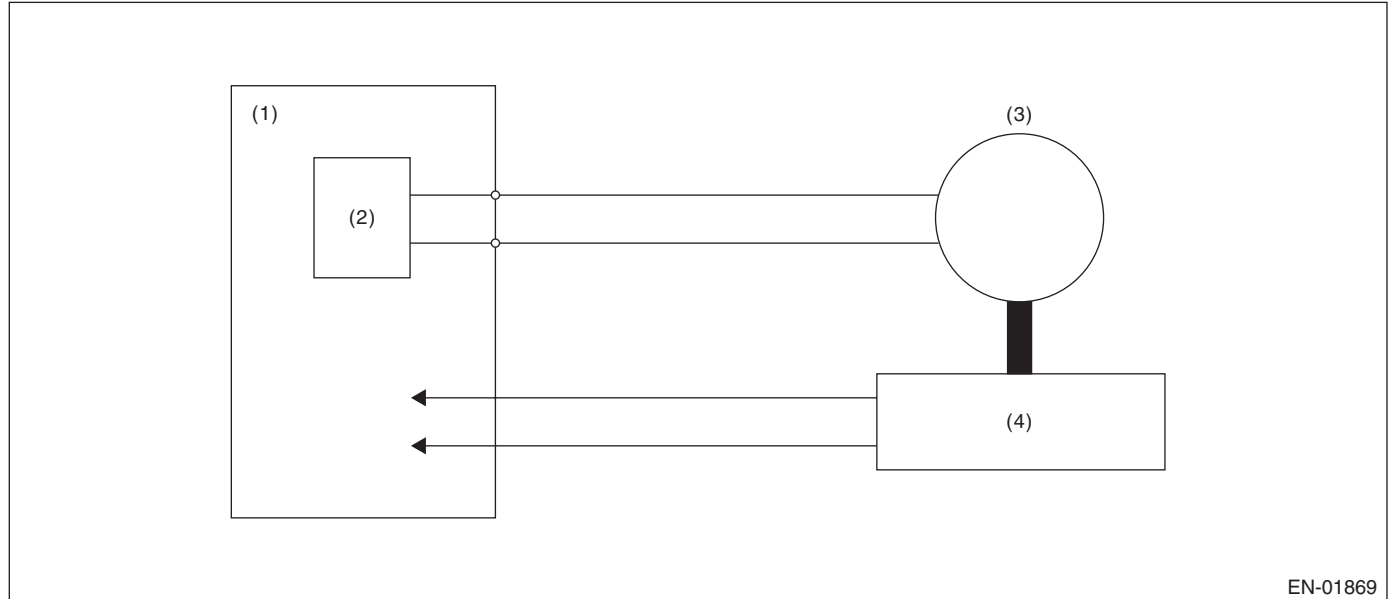

EN-01869

- (1) Engine control module (ECM)      (3) Motor      (4) Throttle position sensor  
 (2) Drive circuit

### 3. ENABLE CONDITIONS

Secondary Parameters	Enable Conditions
None	

### 4. GENERAL DRIVING CYCLE

Perform the diagnosis at full closed point learning.

### 5. DIAGNOSTIC METHOD

If the duration of time while the following conditions are met is longer than the time indicated, judge as NG.

#### Judgment Value

Malfunction Criteria	Threshold Value
Throttle opening angle when the ignition switch is ON – Throttle minimum stop position	< 2.6% (sensor 1) < 2.6% (sensor 2)

**Time Needed for Diagnosis:** 200 ms

**Malfunction Indicator Light Illumination:** Illuminates as soon as a malfunction occurs.

# Diagnostic Trouble Code (DTC) Detecting Criteria

## GENERAL DESCRIPTION

### FY:DTC P2119 THROTTLE ACTUATOR CONTROL THROTTLE BODY RANGE/ PERFORMANCE

#### 1. OUTLINE OF DIAGNOSIS

Judge as NG when the throttle is open stuck, or when the difference between actual throttle opening angle and estimated opening angle is out of range. Judge as NG when any one of the six items for diagnosis is applied.

##### Throttle open stuck:

- Throttle opening angle is out of range
- Intake air amount is out of range

##### When the difference between actual throttle opening angle and estimated opening angle is out of range:

- All time monitoring
- Actual opening angle change amount is small
- Actual opening angle change amount is large
- Actual opening angle does not change

#### 2. ENABLE CONDITIONS

Item	Secondary Parameters	Enable Conditions
Throttle opening angle is out of range	Battery voltage	$\geq 6\text{ V}$
Intake air amount is out of range	DTC P0606 CONTROL MODULE PRO-CESSOR	Under detection
All time monitoring	Battery voltage	$\geq 6\text{ V}$
Actual opening angle change amount is small	Battery voltage Actual opening angle change amount	$\geq 6\text{ V}$ $> 0.84\%/ms$
Actual opening angle change amount is large	Battery voltage Actual opening angle change amount	$\geq 6\text{ V}$ $> 2.1\%/ms$
Actual opening angle does not change	Battery voltage Continuous time when actual opening angle changing amount is 0%/ms	$> 6\text{ V}$ $\geq 5\text{ s}$

#### 3. GENERAL DRIVING CYCLE

Always perform the diagnosis continuously.

# Diagnostic Trouble Code (DTC) Detecting Criteria

GENERAL DESCRIPTION

## 4. DIAGNOSTIC METHOD

Judge as NG if the criteria below are met.

### Judgment Value

Item	Malfunction Criteria	Threshold Value
Throttle opening angle is out of range	Throttle opening angle	$\geq 17.3\%$
Intake air amount is out of range	Amount of intake air	$> 19.2 \text{ g/s (0.68 oz/s)}$
All time monitoring	Difference between actual throttle opening angle and estimated opening angle	$\geq 4.2\%$
Actual opening angle change amount is small	Difference between actual throttle opening angle and estimated opening angle	$\geq 2.1\%$
Actual opening angle change amount is large	Difference between actual throttle opening angle and estimated opening angle	$\geq 4.2\%$
Actual opening angle does not change	Difference between actual throttle opening angle and target throttle opening angle	$\geq 1.68\%$

### Time Needed for Diagnosis:

Item	Time
Throttle opening angle is out of range	200 ms
Intake air amount is out of range	200 ms
All time monitoring	2000 ms
Actual opening angle change amount is small	1000 ms
Actual opening angle change amount is large	500 ms
Actual opening angle does not change	1000 ms

**Malfunction Indicator Light Illumination:** Illuminates as soon as a malfunction occurs.

# Diagnostic Trouble Code (DTC) Detecting Criteria

## GENERAL DESCRIPTION

### FZ: DTC P2122 THROTTLE/PEDAL POSITION SENSOR/SWITCH “D” CIRCUIT LOW INPUT

#### 1. OUTLINE OF DIAGNOSIS

Detect the open or short circuit of accelerator pedal position sensor 1.

Judge as NG if out of specification.

#### 2. COMPONENT DESCRIPTION

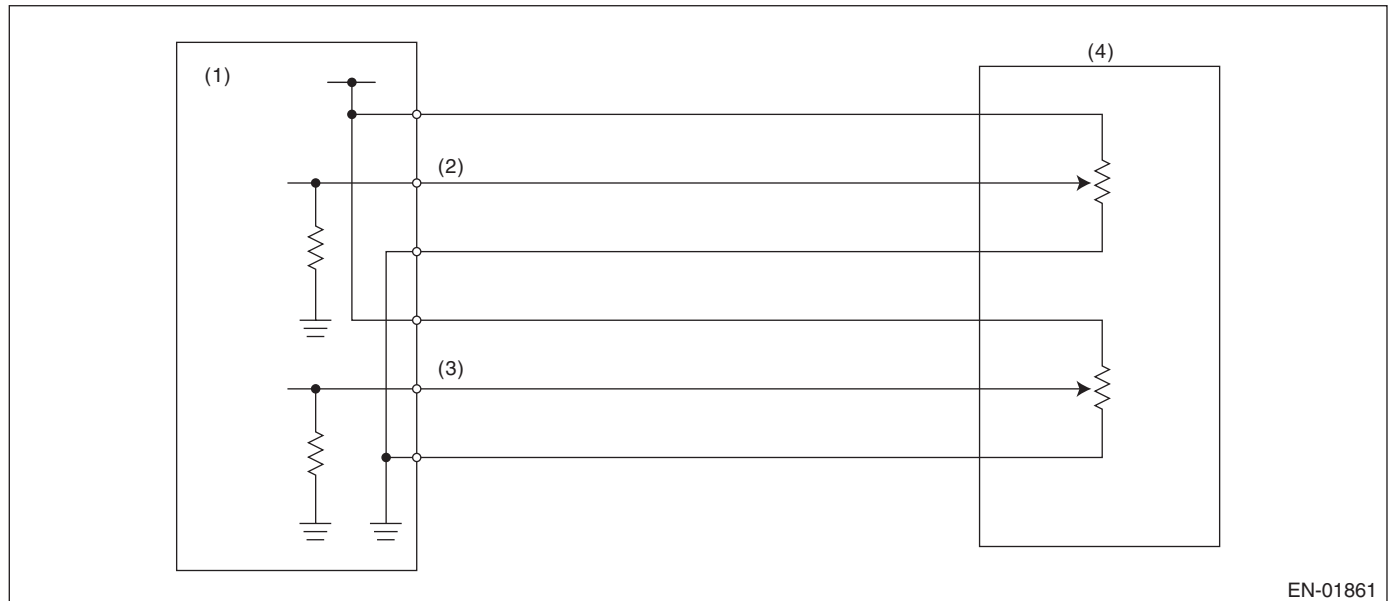

EN-01861

- (1) Engine control module (ECM)      (3) Accelerator pedal position sensor 2 signal      (4) Accelerator pedal position sensor
- (2) Accelerator pedal position sensor 1 signal

#### 3. ENABLE CONDITIONS

Secondary Parameters	Enable Conditions
Battery voltage	$\geq 6 \text{ V}$

#### 4. GENERAL DRIVING CYCLE

Always perform the diagnosis continuously.

#### 5. DIAGNOSTIC METHOD

If the duration of time while the following conditions are met is longer than the time indicated, judge as NG.

##### Judgment Value

Malfunction Criteria	Threshold Value
Sensor 1 output voltage	$< 0.54 \text{ V}$

**Time Needed for Diagnosis:** 100 ms

**Malfunction Indicator Light Illumination:** Illuminates as soon as a malfunction occurs.



# Diagnostic Trouble Code (DTC) Detecting Criteria

GENERAL DESCRIPTION

## GA:DTC P2123 THROTTLE/PEDAL POSITION SENSOR/SWITCH “D” CIRCUIT HIGH INPUT

### 1. OUTLINE OF DIAGNOSIS

Detect the open or short circuit of accelerator pedal position sensor 1.  
Judge as NG if out of specification.

### 2. COMPONENT DESCRIPTION

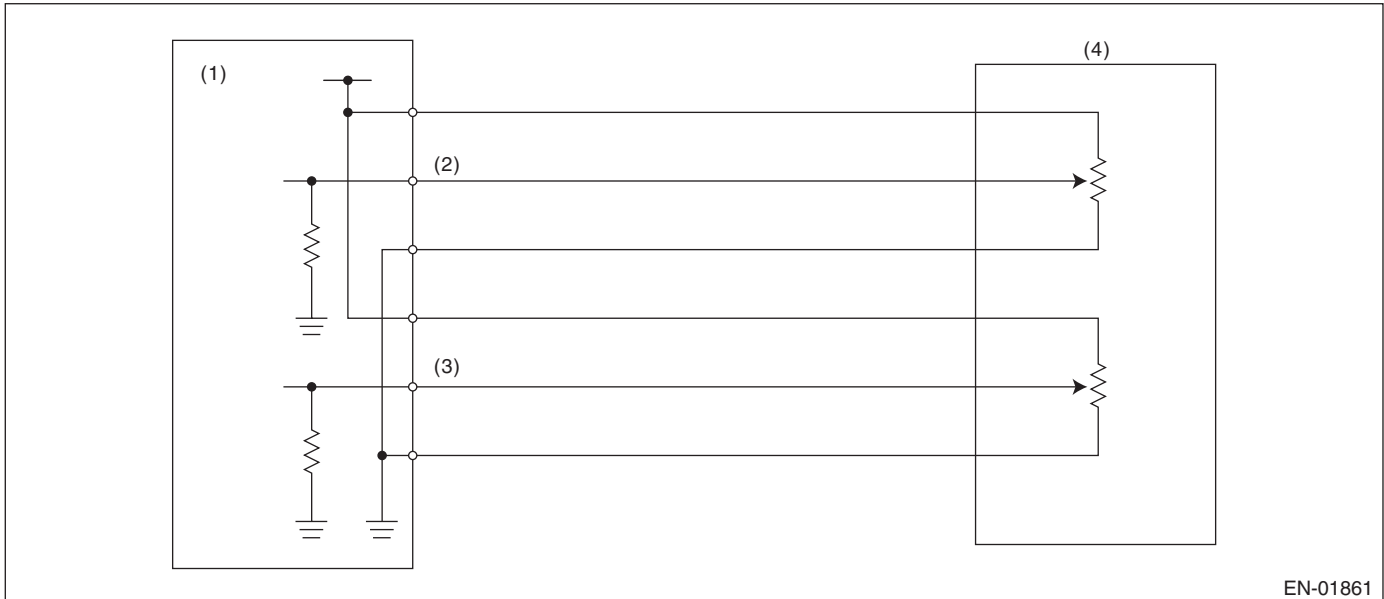

EN-01861

- (1) Engine control module (ECM)      (3) Accelerator pedal position sensor 2 signal      (4) Accelerator pedal position sensor 2 signal  
(2) Accelerator pedal position sensor 1 signal

### 3. ENABLE CONDITIONS

Secondary Parameters	Enable Conditions
Battery voltage	$\geq 6 \text{ V}$

### 4. GENERAL DRIVING CYCLE

Always perform the diagnosis continuously.

### 5. DIAGNOSTIC METHOD

If the duration of time while the following conditions are met is longer than the time indicated, judge as NG.

#### Judgment Value

Malfunction Criteria	Threshold Value
Sensor 1 output voltage	$> 4.77 \text{ V}$

**Time Needed for Diagnosis:** 100 ms

**Malfunction Indicator Light Illumination:** Illuminates as soon as a malfunction occurs.

# Diagnostic Trouble Code (DTC) Detecting Criteria

## GENERAL DESCRIPTION

### GB:DTC P2127 THROTTLE/PEDAL POSITION SENSOR/SWITCH “E” CIRCUIT LOW INPUT

#### 1. OUTLINE OF DIAGNOSIS

Detect the open or short circuit of accelerator pedal position sensor 2.

Judge as NG if out of specification.

#### 2. COMPONENT DESCRIPTION

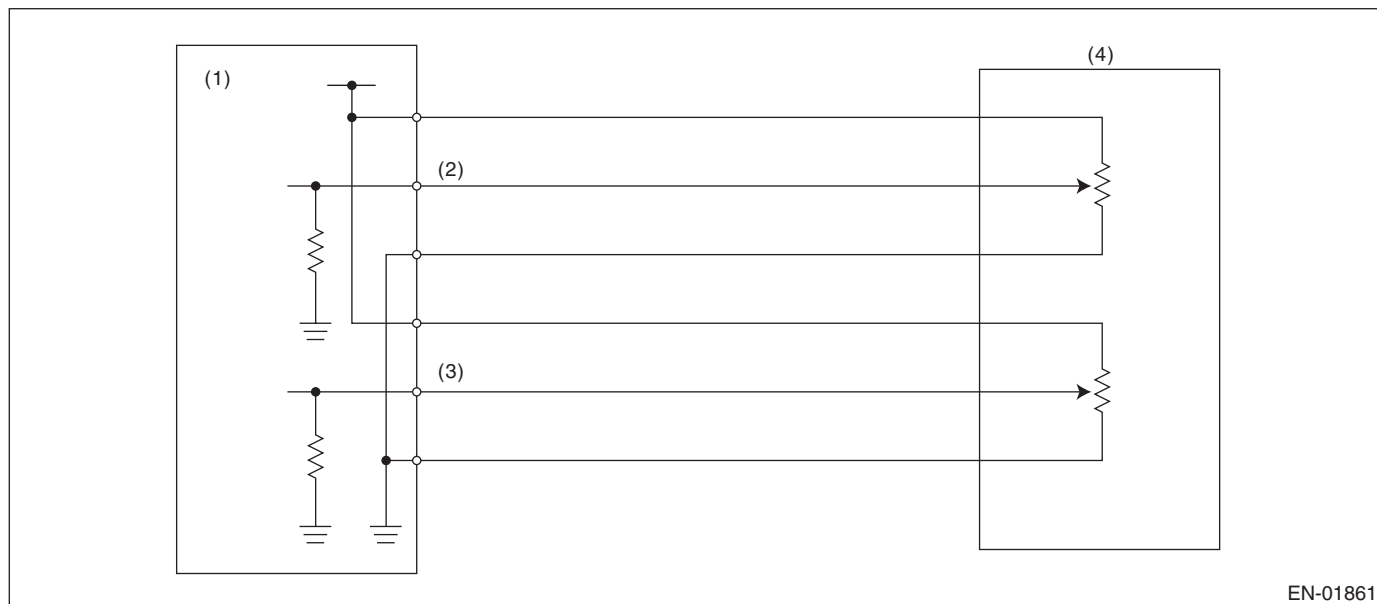

- (1) Engine control module (ECM)      (3) Accelerator pedal position sensor 2 signal      (4) Accelerator pedal position sensor 2 signal
- (2) Accelerator pedal position sensor 1 signal

#### 3. ENABLE CONDITIONS

Secondary Parameters	Enable Conditions
Battery voltage	$\geq 6 \text{ V}$

#### 4. GENERAL DRIVING CYCLE

Always perform the diagnosis continuously.

#### 5. DIAGNOSTIC METHOD

If the duration of time while the following conditions are met is longer than the time indicated, judge as NG.

##### Judgment Value

Malfunction Criteria	Threshold Value
Sensor 2 output voltage	$< 0.54 \text{ V}$

**Time Needed for Diagnosis:** 100 ms

**Malfunction Indicator Light Illumination:** Illuminates as soon as a malfunction occurs.

# Diagnostic Trouble Code (DTC) Detecting Criteria

GENERAL DESCRIPTION

## GC:DTC P2128 THROTTLE/PEDAL POSITION SENSOR/SWITCH “E” CIRCUIT HIGH INPUT

### 1. OUTLINE OF DIAGNOSIS

Detect the open or short circuit of accelerator pedal position sensor 2.  
Judge as NG if out of specification.

### 2. COMPONENT DESCRIPTION

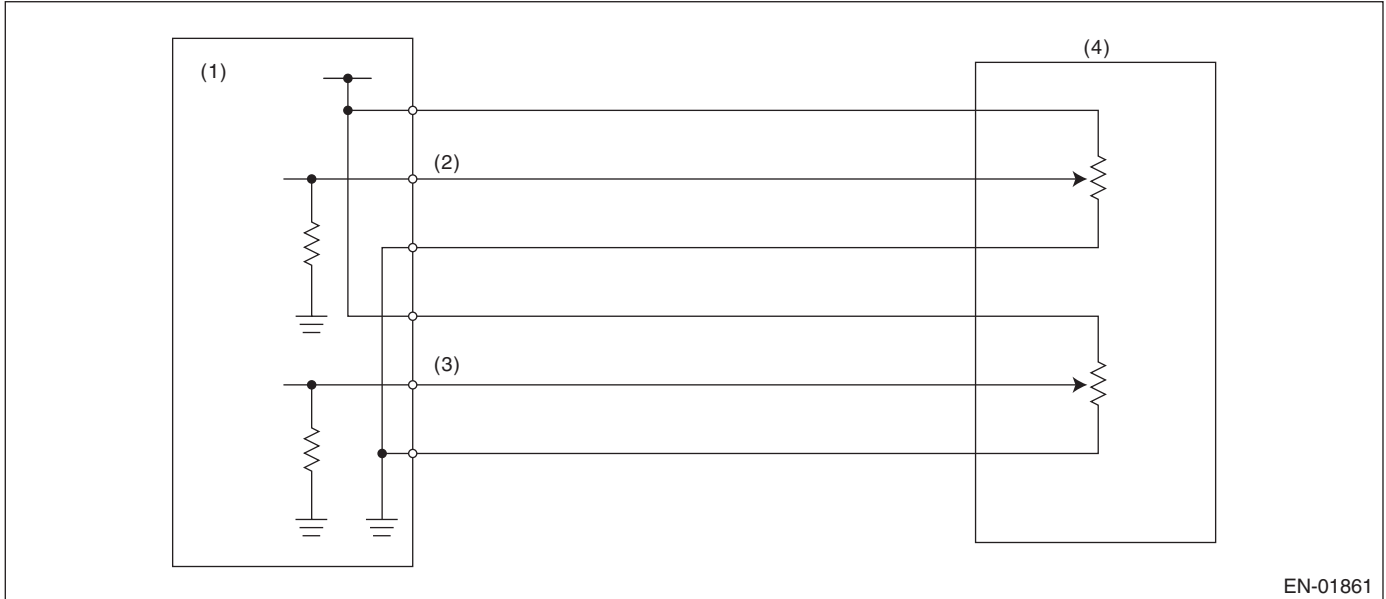

- (1) Engine control module (ECM)      (3) Accelerator pedal position sensor 2 signal      (4) Accelerator pedal position sensor 2 signal  
(2) Accelerator pedal position sensor 1 signal

### 3. ENABLE CONDITIONS

Secondary Parameters	Enable Conditions
Battery voltage	$\geq 6\text{ V}$

### 4. GENERAL DRIVING CYCLE

Always perform the diagnosis continuously.

### 5. DIAGNOSTIC METHOD

If the duration of time while the following conditions are met is longer than the time indicated, judge as NG.

#### Judgment Value

Malfunction Criteria	Threshold Value
Sensor 2 output voltage	$> 4.77\text{ V}$

**Time Needed for Diagnosis:** 100 ms

**Malfunction Indicator Light Illumination:** Illuminates as soon as a malfunction occurs.

# Diagnostic Trouble Code (DTC) Detecting Criteria

## GENERAL DESCRIPTION

### GD:DTC P2135 THROTTLE/PEDAL POSITION SENSOR/SWITCH “A”/“B” VOLTAGE CORRELATION

#### 1. OUTLINE OF DIAGNOSIS

Judge as NG when the signal level of throttle position sensor 1 is different from the throttle position sensor 2.

#### 2. COMPONENT DESCRIPTION

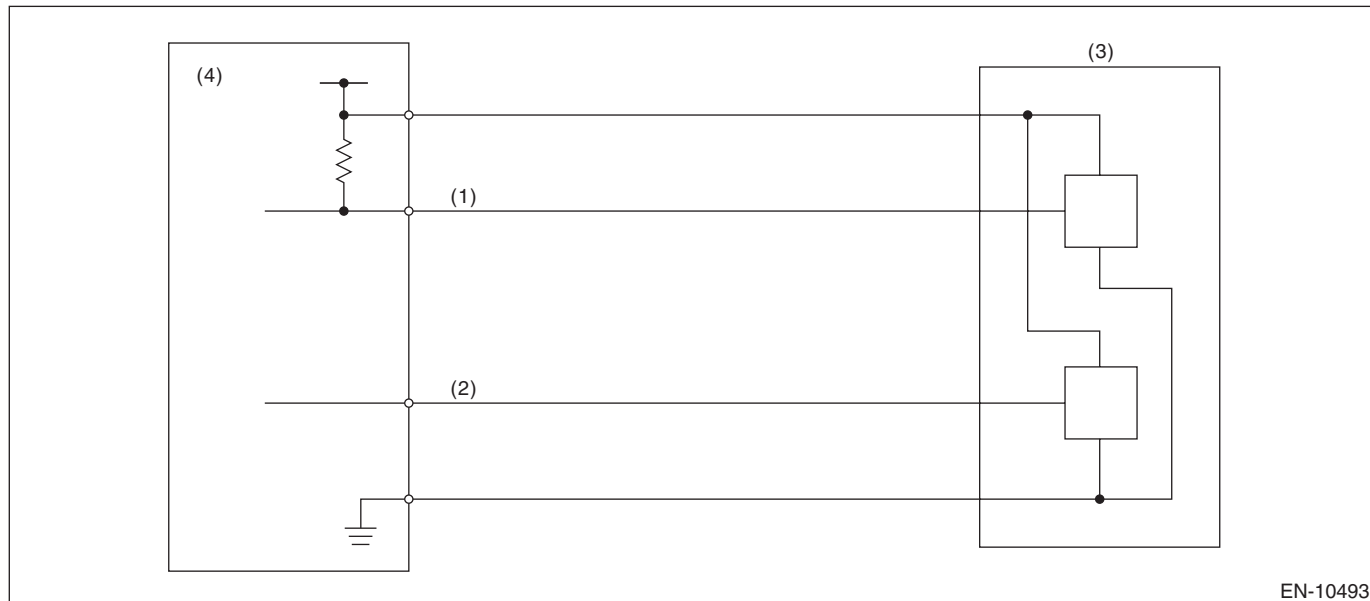

EN-10493

- (1) Throttle position sensor 1 signal      (3) Throttle position sensor      (4) Engine control module (ECM)  
 (2) Throttle position sensor 2 signal

#### 3. ENABLE CONDITIONS

Secondary Parameters	Enable Conditions
Battery voltage	$\geq 6 \text{ V}$

#### 4. GENERAL DRIVING CYCLE

Always perform the diagnosis continuously.

#### 5. DIAGNOSTIC METHOD

If the duration of time while the following conditions are met is longer than the time indicated, judge as NG.

##### Judgment Value

Malfunction Criteria	Threshold Value
$ \text{Throttle position sensor 1 voltage} - (5 \text{ V} - \text{throttle position sensor 2 voltage}) $	$> 0.79 \text{ V}$

**Time Needed for Diagnosis:** 120 ms

**Malfunction Indicator Light Illumination:** Illuminates as soon as a malfunction occurs.

# Diagnostic Trouble Code (DTC) Detecting Criteria

GENERAL DESCRIPTION

## GE:DTC P2138 THROTTLE/PEDAL POSITION SENSOR/SWITCH “D”/“E” VOLTAGE CORRELATION

### 1. OUTLINE OF DIAGNOSIS

Judge as NG when the signal level of accelerator pedal position sensor 1 is different from the accelerator pedal position sensor 2.

### 2. COMPONENT DESCRIPTION

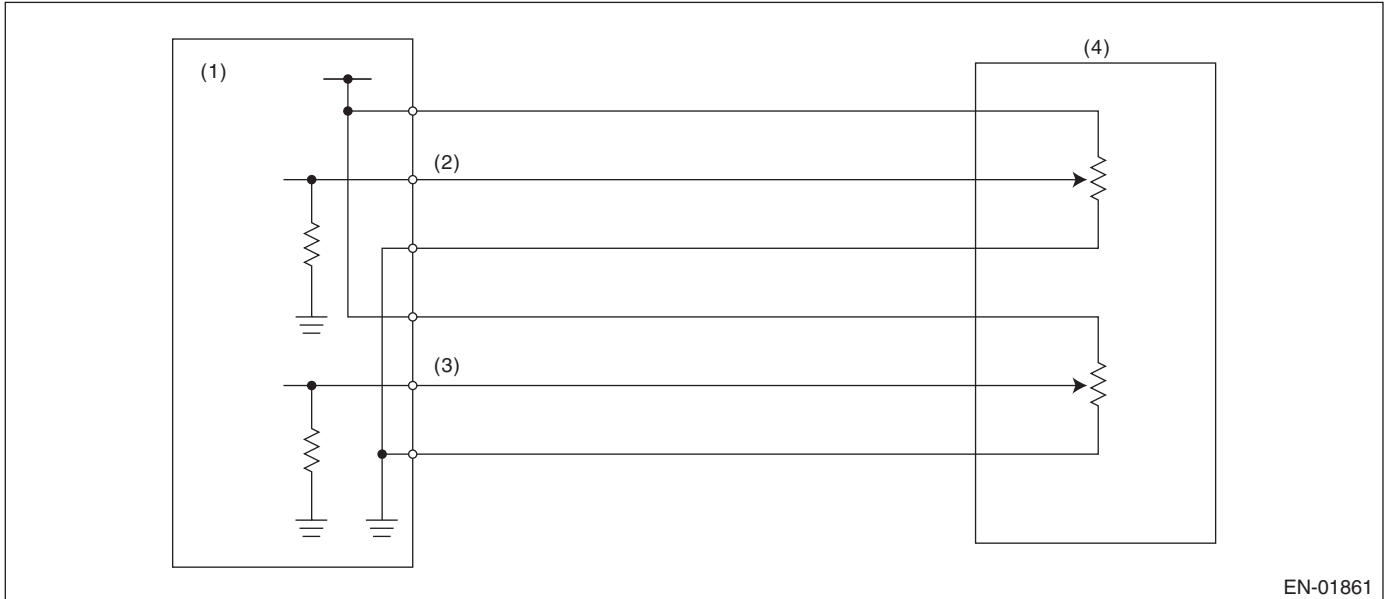

- (1) Engine control module (ECM)      (3) Accelerator pedal position sensor 2 signal      (4) Accelerator pedal position sensor 2 signal
- (2) Accelerator pedal position sensor 1 signal

### 3. ENABLE CONDITIONS

Secondary Parameters	Enable Conditions
Battery voltage	≥ 6 V

### 4. GENERAL DRIVING CYCLE

Always perform the diagnosis continuously.

### 5. DIAGNOSTIC METHOD

If the duration of time while the following conditions are met is longer than the time indicated, judge as NG.

#### Judgment Value

Malfunction Criteria	Threshold Value
Signal difference between two sensors	Within NG range of <b>Details of Judgment value</b>

# Diagnostic Trouble Code (DTC) Detecting Criteria

## GENERAL DESCRIPTION

### Details of Judgment Value

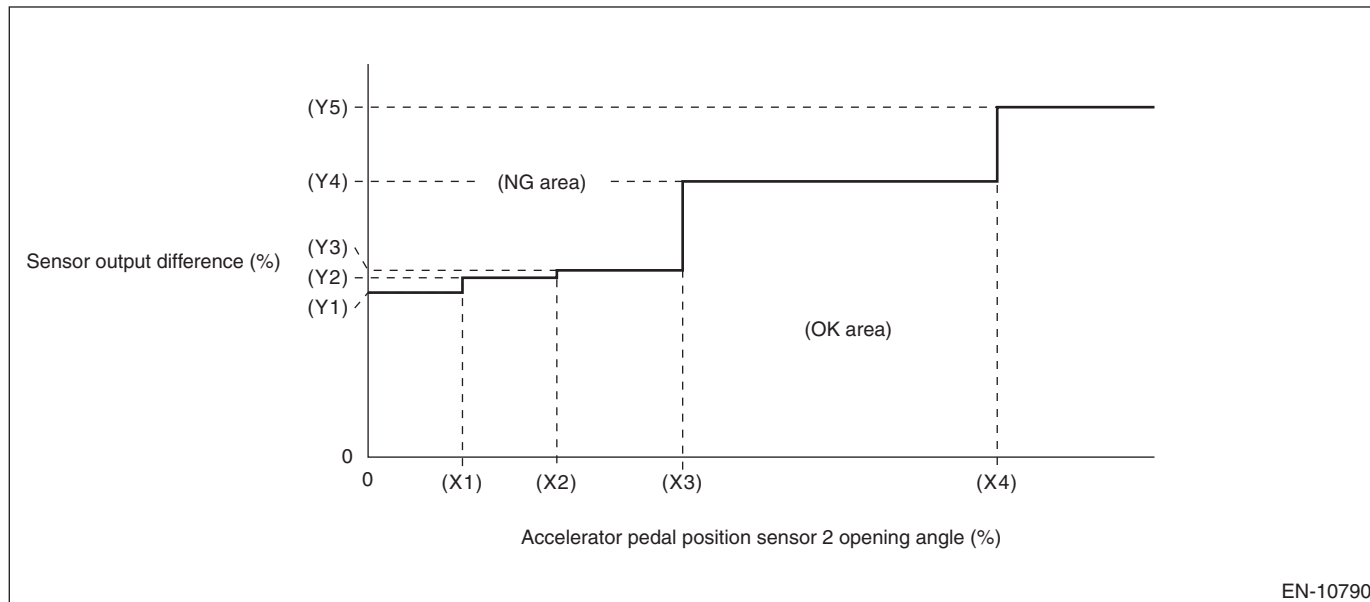

(X1) 1.82%  
(X4) 12.12%

(X2) 3.64%

(X3) 6.06%

(Y1) 4.44%  
(Y4) 7.44%

(Y2) 4.84%  
(Y5) 9.44%

(Y3) 5.04%

**Time Needed for Diagnosis:** 140 ms

**Malfunction Indicator Light Illumination:** Illuminates as soon as a malfunction occurs.

# Diagnostic Trouble Code (DTC) Detecting Criteria

GENERAL DESCRIPTION

## GF:DTC P2146 FUEL INJECTOR POWER SUPPLY A OPEN CIRCUIT

### 1. OUTLINE OF DIAGNOSIS

Detect the open/short circuit of injector power supply circuit and injector booster circuit.

### 2. ENABLE CONDITIONS

Secondary Parameters	Enable Conditions
Battery voltage	$\geq 10.9$ V
Injector power supply voltage (diagnosis 2 only)	6 — 17.2 V

### 3. GENERAL DRIVING CYCLE

Always perform the diagnosis continuously.

### 4. DIAGNOSTIC METHOD

If the duration of time while the following conditions are met is longer than the time indicated, judge as NG.

#### Diagnosis 1

##### Judgment Value

Malfunction Criteria	Threshold Value
Injector power supply voltage	< 6 V or > 17.2 V

#### Diagnosis 2

##### Judgment Value

Malfunction Criteria	Threshold Value
Injector booster power supply voltage	< 5.98 V or > 70.72 V

#### Time Needed for Diagnosis:

- Diagnosis 1: 1000 ms
- Diagnosis 2: 280 ms

**Malfunction Indicator Light Illumination:** Illuminates as soon as a malfunction occurs.

# Diagnostic Trouble Code (DTC) Detecting Criteria

## GENERAL DESCRIPTION

---

### GG:DTC P2158 VEHICLE SPEED SENSOR "B"

#### 1. OUTLINE OF DIAGNOSIS

Judge as NG when outside of the judgment value.

Judge NG when the received data from VDCCM&H/U is abnormal vehicle speed, and the vehicle speed data is impossible.

#### 2. COMPONENT DESCRIPTION

Vehicle speed signals are taken in to the VDC control module and hydraulic control unit, and normal/erroneous data of the ABS wheel speed sensor is received by CAN communication from the VDC control module and hydraulic control unit.

#### 3. ENABLE CONDITIONS

Secondary Parameters	Enable Conditions
Battery voltage	$\geq 10.9$ V

#### 4. GENERAL DRIVING CYCLE

Always perform the diagnosis continuously after the enable conditions have been established.

#### 5. DIAGNOSTIC METHOD

If the duration of time while the following conditions are met is longer than the time indicated, judge as NG.

##### Judgment Value

Malfunction Criteria	Threshold Value
Speed of LH wheel received from VDC control module & hydraulic control unit	$\geq 300$ km/h (186.4 MPH)

**Time Needed for Diagnosis:** 2560 ms

**Malfunction Indicator Light Illumination:** Illuminates as soon as a malfunction occurs.



# Diagnostic Trouble Code (DTC) Detecting Criteria

GENERAL DESCRIPTION

## GH:DTC P2195 O2 SENSOR SIGNAL BIASED/STUCK LEAN (BANK 1 SENSOR 1)

### 1. OUTLINE OF DIAGNOSIS

Detect that  $\lambda$  value remains low.

Judge as NG when lambda value is determined as abnormal in accordance with driving conditions such as intake air amount, sub feedback control, and front oxygen (A/F) sensor  $\lambda$  value and rear oxygen sensor voltage value.

$\lambda$  value = Actual air fuel ratio/Theoretical air fuel ratio

$\lambda > 1$ : Lean

$\lambda < 1$ : Rich

### 2. COMPONENT DESCRIPTION

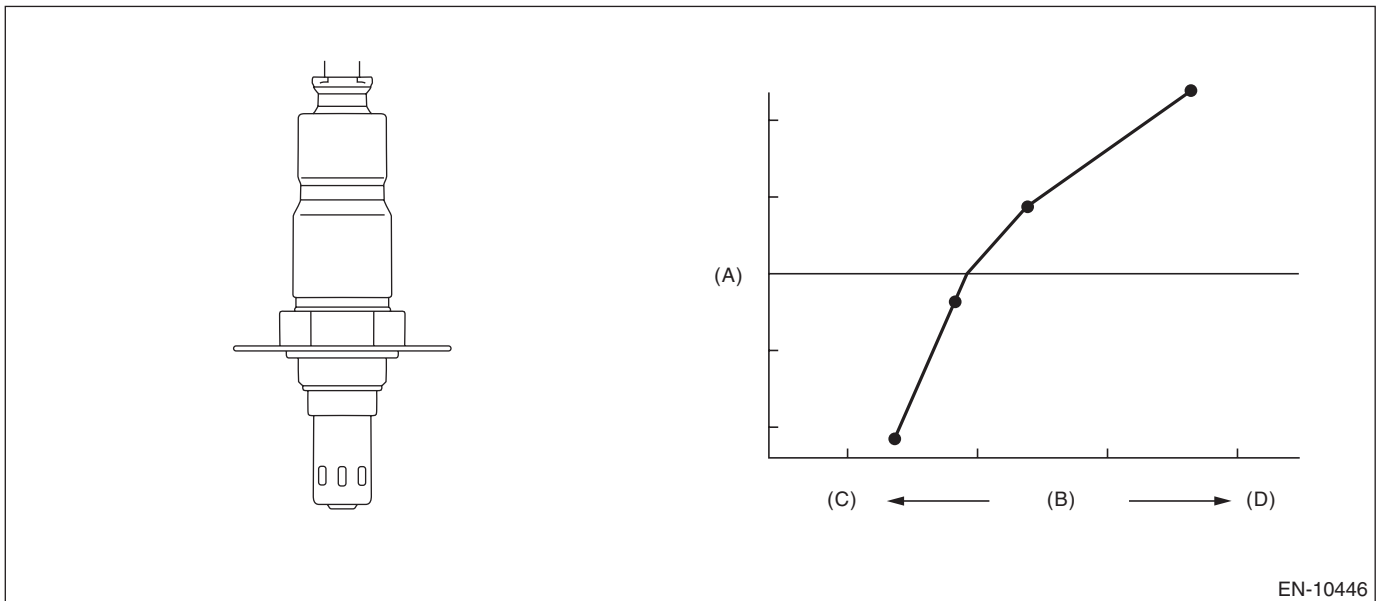

(A) Electromotive force

(B) Air fuel ratio

(C) Rich

(D) Lean

### 3. ENABLE CONDITIONS

Secondary Parameters	Enable Conditions
Battery voltage	$\geq 10.9$ V
Main feedback	In operation
Amount of intake air	$\geq 6$ g/s (0.21 oz/s)
Estimated temperature of the rear oxygen sensor element	$\geq 450^\circ\text{C}$ (842°F)

### 4. GENERAL DRIVING CYCLE

Perform the diagnosis continuously when the conditions are established.

# Diagnostic Trouble Code (DTC) Detecting Criteria

## GENERAL DESCRIPTION

---

### 5. DIAGNOSTIC METHOD

If the duration of time while the following conditions are met is longer than the time indicated, judge as NG.

#### Judgment Value

Malfunction Criteria	Threshold Value
$\lambda$ value	< 0.85
Rear oxygen sensor voltage value	$\leq$ 150 mV

**Time Needed for Diagnosis:** 10000 ms

**Malfunction Indicator Light Illumination:** Illuminates when malfunction occurs in 2 continuous driving cycles.

# Diagnostic Trouble Code (DTC) Detecting Criteria

GENERAL DESCRIPTION

## GI: DTC P2196 O2 SENSOR SIGNAL BIASED/STUCK RICH (BANK 1 SENSOR 1)

### 1. OUTLINE OF DIAGNOSIS

Detect that  $\lambda$  value remains high.

Judge as NG when lambda value is determined as abnormal in accordance with driving conditions such as intake air amount, sub feedback control, and front oxygen (A/F) sensor  $\lambda$  value and rear oxygen sensor voltage value.

$\lambda$  value = Actual air fuel ratio/Theoretical air fuel ratio

$\lambda > 1$ : Lean

$\lambda < 1$ : Rich

### 2. COMPONENT DESCRIPTION

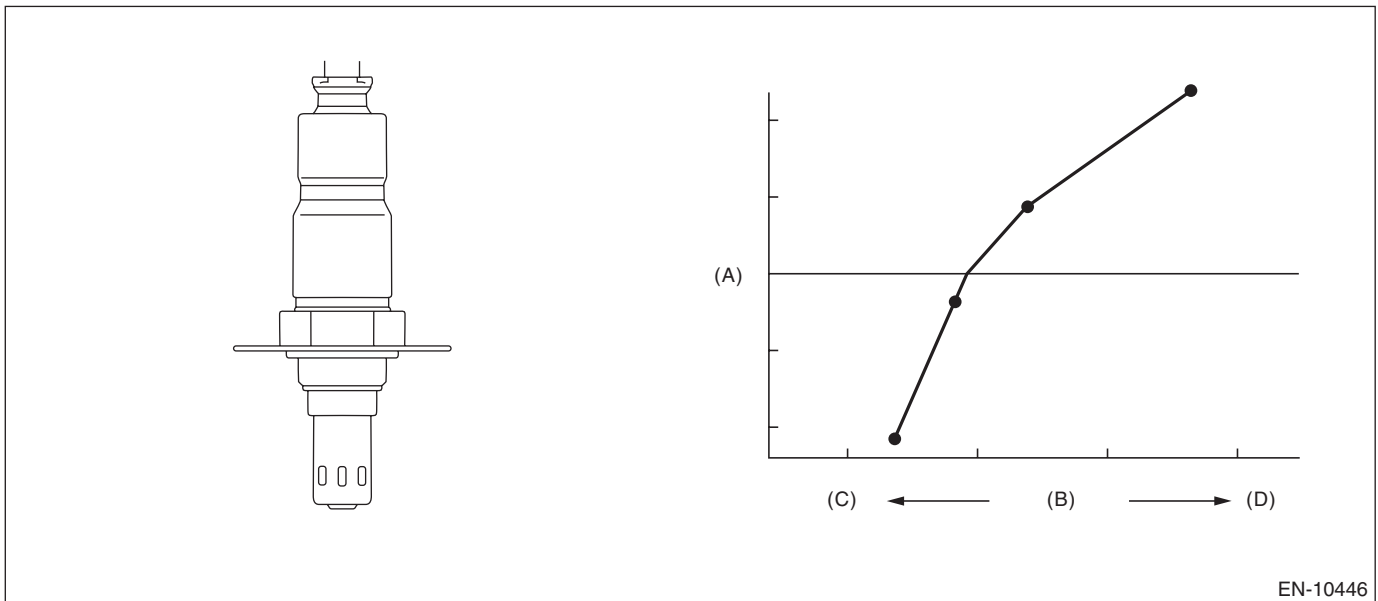

(A) Electromotive force

(B) Air fuel ratio

(C) Rich

(D) Lean

### 3. ENABLE CONDITIONS

Secondary Parameters	Enable Conditions
Battery voltage	$\geq 10.9$ V
Main feedback	In operation
Amount of intake air	$\geq 6$ g/s (0.21 oz/s)
Estimated temperature of the rear oxygen sensor element	$\geq 450^{\circ}\text{C}$ (842 $^{\circ}\text{F}$ )

### 4. GENERAL DRIVING CYCLE

Perform the diagnosis continuously when the conditions are established.

# Diagnostic Trouble Code (DTC) Detecting Criteria

## GENERAL DESCRIPTION

---

### 5. DIAGNOSTIC METHOD

If the duration of time while the following conditions are met is longer than the time indicated, judge as NG.

#### Judgment Value

Malfunction Criteria	Threshold Value
$\lambda$ value	> 1.15
Rear oxygen sensor voltage value	$\geq$ 550 mV

**Time Needed for Diagnosis:** 10000 ms

**Malfunction Indicator Light Illumination:** Illuminates when malfunction occurs in 2 continuous driving cycles.

## **GJ:DTC P219A BANK 1 AIR-FUEL RATIO IMBALANCE**

### **1. OUTLINE OF DIAGNOSIS**

This diagnostic monitor performs a functional check of the fuel system to determine an air-fuel ratio cylinder imbalance.

This diagnosis is composed of two monitors.

The outline of “monitor A1” is as follows. When an air-fuel ratio cylinder imbalance occurs, the primary oxygen sensor output signal will oscillate with increased amplitude. This monitor utilizes this behavior to make a diagnosis. The monitor integrates the difference between the amplification value and the mean value of the first oxygen sensor output signal and compares it to a threshold to make a judgment.

The outline of “monitor B1” is as follows. Similarly, when an imbalance occurs, the engine speed also fluctuates with increased amplitude. This monitor utilizes this behavior to make a diagnosis. For reference, it should be noted that this imbalance monitor method is actually similar to the current misfire diagnostic monitor, and the parameter “domg360” (units: degrees CA) is shared between the imbalance and misfire monitors. The imbalance monitor is performed during idle condition when the engine is warm. The monitor integrates the count of “domg360” which exceeds a threshold in 1000 revolution.

When both the “monitor A1” value and the “monitor B1” value exceed a predetermined threshold, this monitor determines a malfunction and stores a fault code.

# Diagnostic Trouble Code (DTC) Detecting Criteria

## GENERAL DESCRIPTION

### Monitor A1

When there is an air-fuel ratio cylinder imbalance malfunction, the primary oxygen sensor output fluctuates widely compared with a normal sensor, as shown by the chain line in Figure 1 below. This monitor makes a diagnosis based on this phenomenon. Each primary oxygen sensor signal (PS) and mean value of the primary oxygen sensor signal (MS) is calculated from the primary oxygen sensor signal. The absolute values of (PS – MS) are sampled every 4 ms as shown in the figure. Diagnostic value 1 (DV1) is obtained by integrating the absolute value of (PS – MS) for 2500 times. A malfunction is determined when DV1 exceeds the threshold. The judgment values are determined experimentally.

**Figure 1. Compare malfunctioned primary oxygen sensor output with a normal sensor**

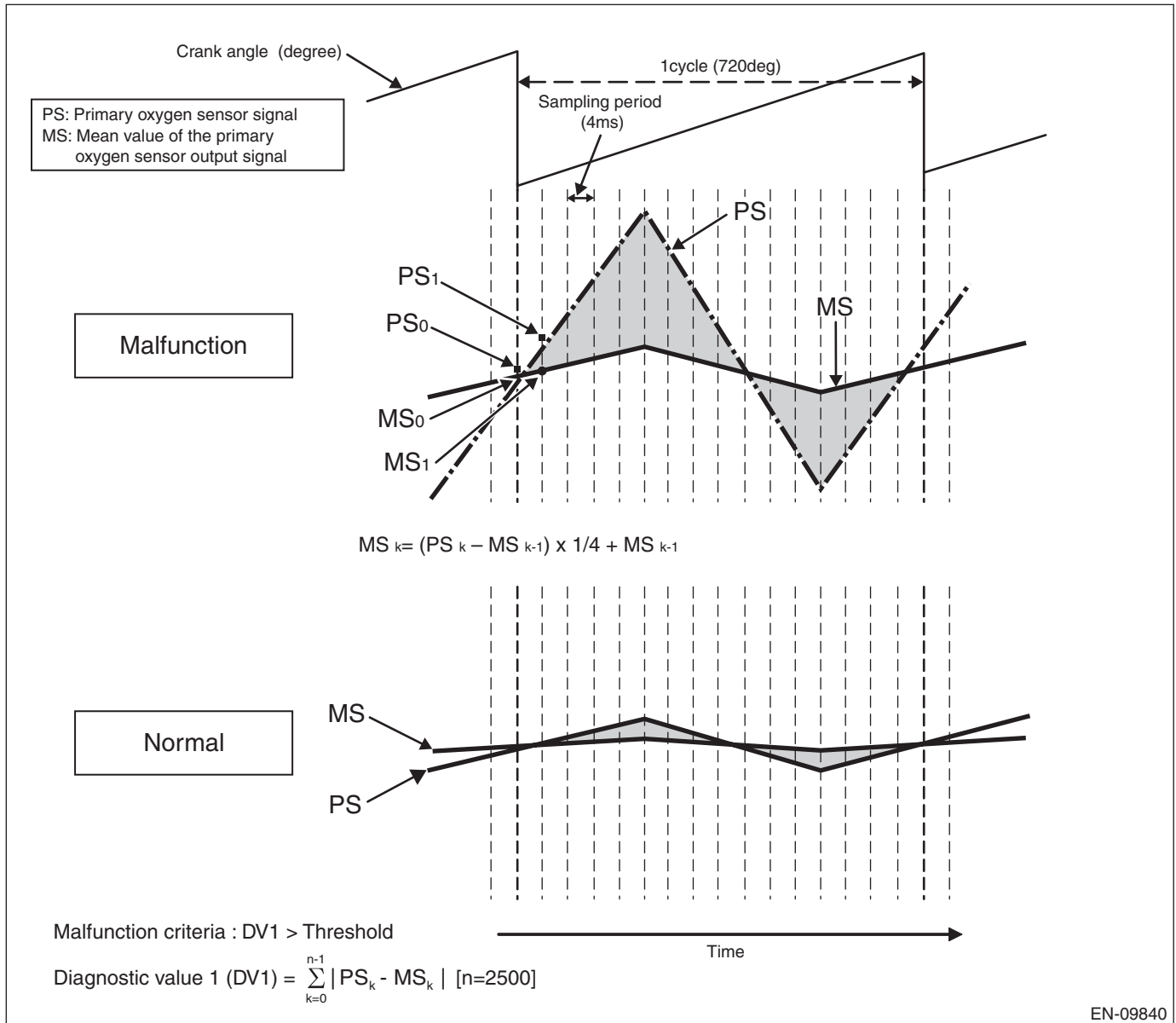

# Diagnostic Trouble Code (DTC) Detecting Criteria

GENERAL DESCRIPTION

## Monitor B1

**Method used:** Difference method of 360 degrees CA

**Monitor value:**  $domg360 = (omg\ 1 - omg\ 0) - (omg\ 3 - omg\ 2) = \text{angular speed}$

Each crankshaft angular speed is defined as Figure 2 below.

**Figure 2. Description of domg360 output**

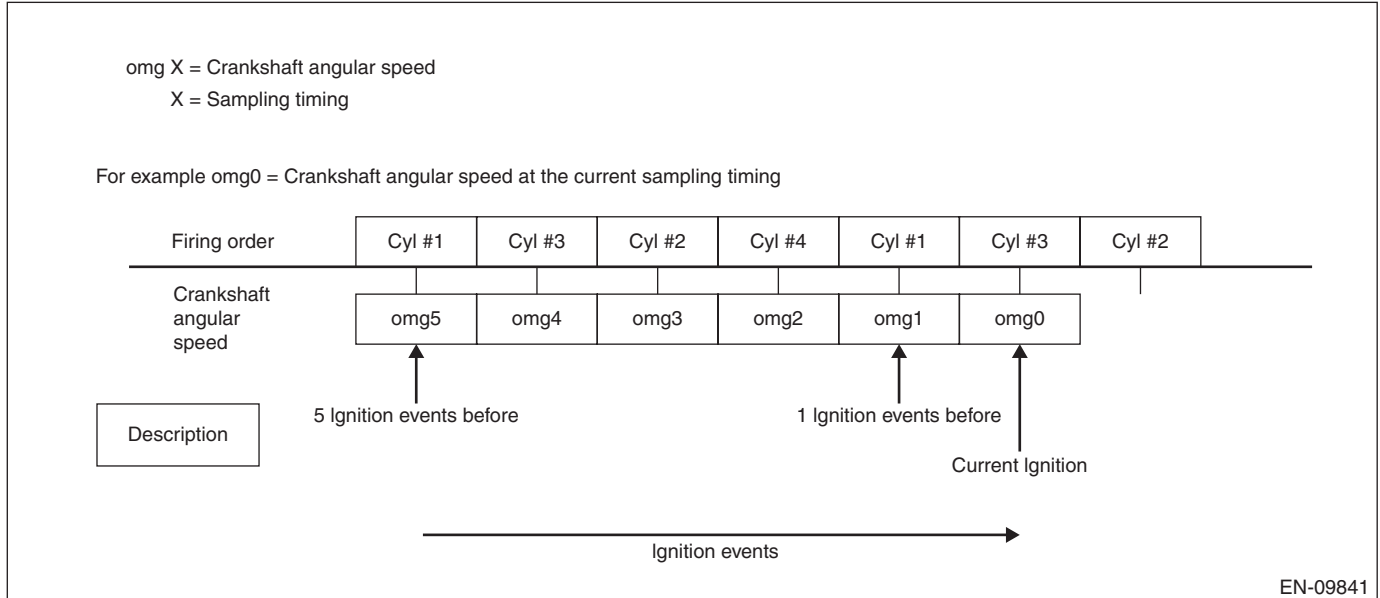

This method uses the fact that the domg360 of lean conditioned cylinder caused by imbalance malfunction indicates big value, as shown by the chain line in Figure 3 below.

The number of times for domg360 to exceed the judgment value in 1000 revolutions (500 cycles) is calculated as diagnostic value 2 (DV2). A malfunction is determined when DV2 exceeds the threshold.

**Figure 3. Compare malfunctioned domg360 output with a normal output**

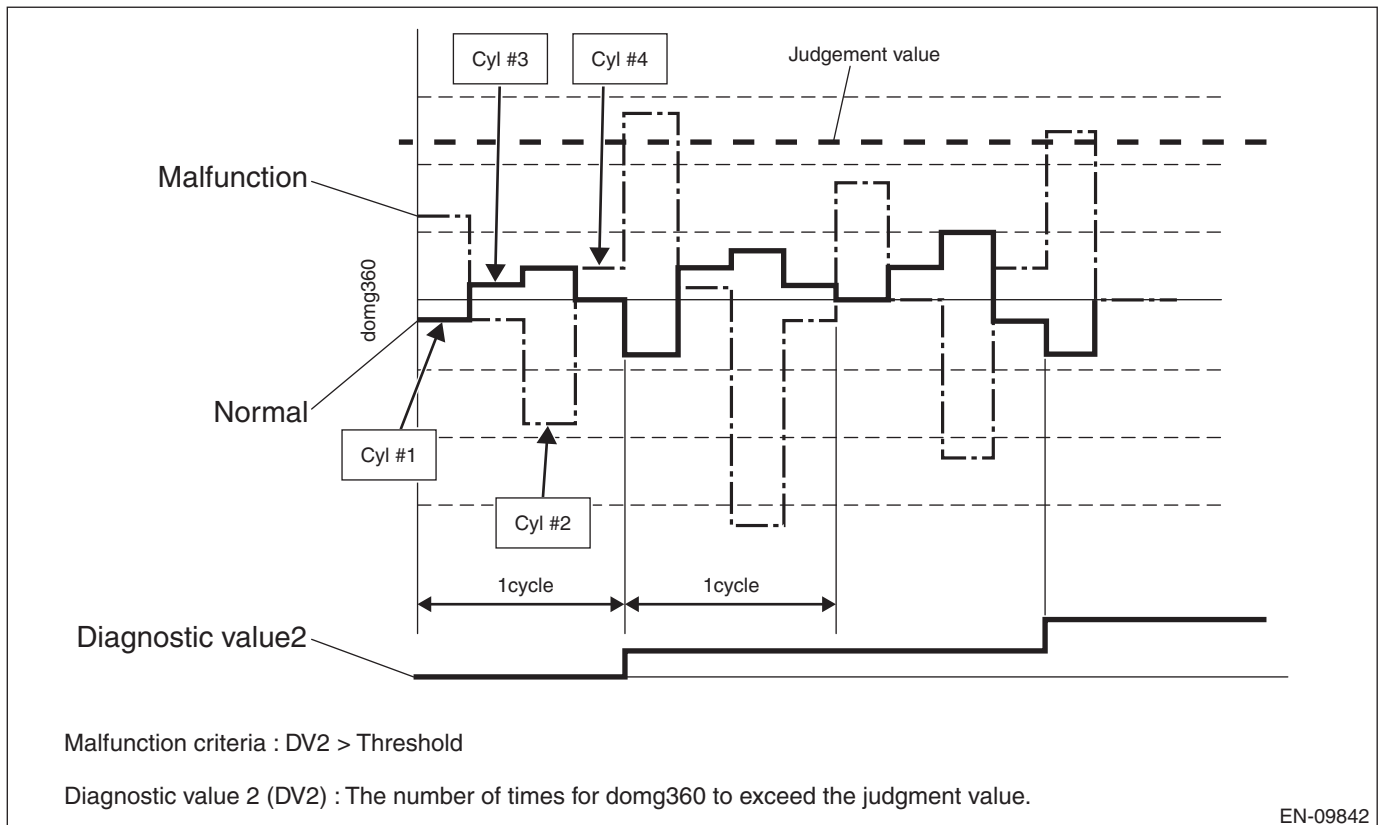

# Diagnostic Trouble Code (DTC) Detecting Criteria

## GENERAL DESCRIPTION

---

### 2. ENABLE CONDITIONS

#### Monitor A1: Primary oxygen sensor fluctuation

Secondary Parameters	Enable Conditions
Battery voltage	≥ 10.9 V
Atmospheric pressure	≥ 75 kPa (563 mmHg, 22.2 inHg)
Fuel system status (Primary oxygen sensor)	Closed loop
Engine speed	> 1500 rpm and < 4000 rpm
Charging efficiency	≥ 80%

#### Monitor B1: Crankshaft speed fluctuation

Secondary Parameters	Enable Conditions
Misfire diagnosis monitor	Active
Accelerator pedal position	= 0%
Vehicle speed	≤ 1.93 km/h (1.2 MPH)
Engine speed	> 475 rpm and < 900 rpm
Charging efficiency	> 0% and < 45%

### 3. GENERAL DRIVING CYCLE

Always perform the diagnosis continuously.



# Diagnostic Trouble Code (DTC) Detecting Criteria

GENERAL DESCRIPTION

## 4. DIAGNOSTIC METHOD

Judge as NG when Monitor A1 and Monitor B1 are both NG, and when either is OK, judge as OK.

### Monitor A1

Judge as NG when the following conditions are established.

#### Judgment Value

Malfunction Criteria	Threshold Value
Diagnostic value 1 (DV1)	> Threshold value 1 (TV1)

Threshold value 1 (TV1):

$$\sum_{k=0}^{n-1} \text{Map}_k \quad [n=2500]$$

EN-09888

#### Map

		Charging efficiency (%)				
		80	90	100	110	120
Engine speed (rpm)	1500	0.006	0.007	0.010	0.006	0.006
	2000	0.005	0.008	0.012	0.017	0.018
	2500	0.007	0.011	0.018	0.029	0.030
	3000	0.011	0.014	0.017	0.029	0.030
	3500	0.011	0.016	0.018	0.029	0.030
	4000	0.020	0.027	0.024	0.029	0.030

**Time Needed for Diagnosis:** 10 seconds

### Monitor B1

Judge as NG when the following conditions are established.

#### Judgment Value

Malfunction Criteria	Threshold Value
Diagnostic Value2 (DV2)	> 30 count

**Time Needed for Diagnosis:** 750 engine revs.

**Malfunction Indicator Light Illumination:** Illuminates when malfunction occurs in 2 continuous driving cycles.

# Diagnostic Trouble Code (DTC) Detecting Criteria

## GENERAL DESCRIPTION

---

### GK:DTC P2227 BAROMETRIC PRESSURE CIRCUIT RANGE/PERFORMANCE

#### 1. OUTLINE OF DIAGNOSIS

Detect the malfunction of barometric pressure sensor output property.

Judge as NG when the barometric pressure sensor output is largely different from the intake manifold pressure at engine start.

#### 2. COMPONENT DESCRIPTION

The barometric pressure sensor is built into the ECM.

#### 3. ENABLE CONDITIONS

Secondary Parameters	Enable Conditions
Soaking time	≥ 60 s
Elapsed time after ignition switch is turned to ON	< 60 s

#### 4. GENERAL DRIVING CYCLE

Perform the diagnosis once at ignition switch ON.

#### 5. DIAGNOSTIC METHOD

If the duration of time while the following conditions are met is longer than the time indicated, judge as NG.

##### Judgment Value

Malfunction Criteria	Threshold Value
Barometric pressure – Intake manifold pressure at engine start	≥ 12.73 kPa (95.5 mmHg, 3.8 inHg)

**Time Needed for Diagnosis:** 3.2 seconds

**Malfunction Indicator Light Illumination:** Illuminates when malfunction occurs in 2 continuous driving cycles.

# Diagnostic Trouble Code (DTC) Detecting Criteria

GENERAL DESCRIPTION

## GL:DTC P2228 BAROMETRIC PRESSURE CIRCUIT LOW

### 1. OUTLINE OF DIAGNOSIS

Detect the open/short circuit of the barometric pressure sensor.  
Judge as NG if out of specification.

### 2. COMPONENT DESCRIPTION

The barometric pressure sensor is built into the ECM.

### 3. ENABLE CONDITIONS

Secondary Parameters	Enable Conditions
None	

### 4. GENERAL DRIVING CYCLE

Always perform the diagnosis continuously.

### 5. DIAGNOSTIC METHOD

If the duration of time while the following conditions are met is longer than the time indicated, judge as NG.

#### Judgment Value

Malfunction Criteria	Threshold Value
Output voltage	< 1.76 V

**Time Needed for Diagnosis:** 520 ms

**Malfunction Indicator Light Illumination:** Illuminates as soon as a malfunction occurs.

# Diagnostic Trouble Code (DTC) Detecting Criteria

## GENERAL DESCRIPTION

---

### GM:DTC P2229 BAROMETRIC PRESSURE CIRCUIT HIGH

#### 1. OUTLINE OF DIAGNOSIS

Detect the open/short circuit of the barometric pressure sensor.  
Judge as NG if out of specification.

#### 2. COMPONENT DESCRIPTION

The barometric pressure sensor is built into the ECM.

#### 3. ENABLE CONDITIONS

Secondary Parameters	Enable Conditions
None	

#### 4. GENERAL DRIVING CYCLE

Always perform the diagnosis continuously.

#### 5. DIAGNOSTIC METHOD

If the duration of time while the following conditions are met is longer than the time indicated, judge as NG.

##### Judgment Value

Malfunction Criteria	Threshold Value
Output voltage	> 4.6 V

**Time Needed for Diagnosis:** 520 ms

**Malfunction Indicator Light Illumination:** Illuminates as soon as a malfunction occurs.

# Diagnostic Trouble Code (DTC) Detecting Criteria

GENERAL DESCRIPTION

## GN:DTC P2270 O2 SENSOR SIGNAL BIASED/STUCK LEAN (BANK 1 SENSOR 2)

### 1. OUTLINE OF DIAGNOSIS

Detect the stuck of rear oxygen sensor voltage in lean state.

When rear oxygen sensor voltage remains below the threshold value for predetermined time, diagnosis interrupts target air fuel ratio for control and raises output voltage.

Judge as NG detecting the stuck in lean state when rear oxygen sensor voltage remains below the threshold value even after the interrupt control.

### 2. COMPONENT DESCRIPTION

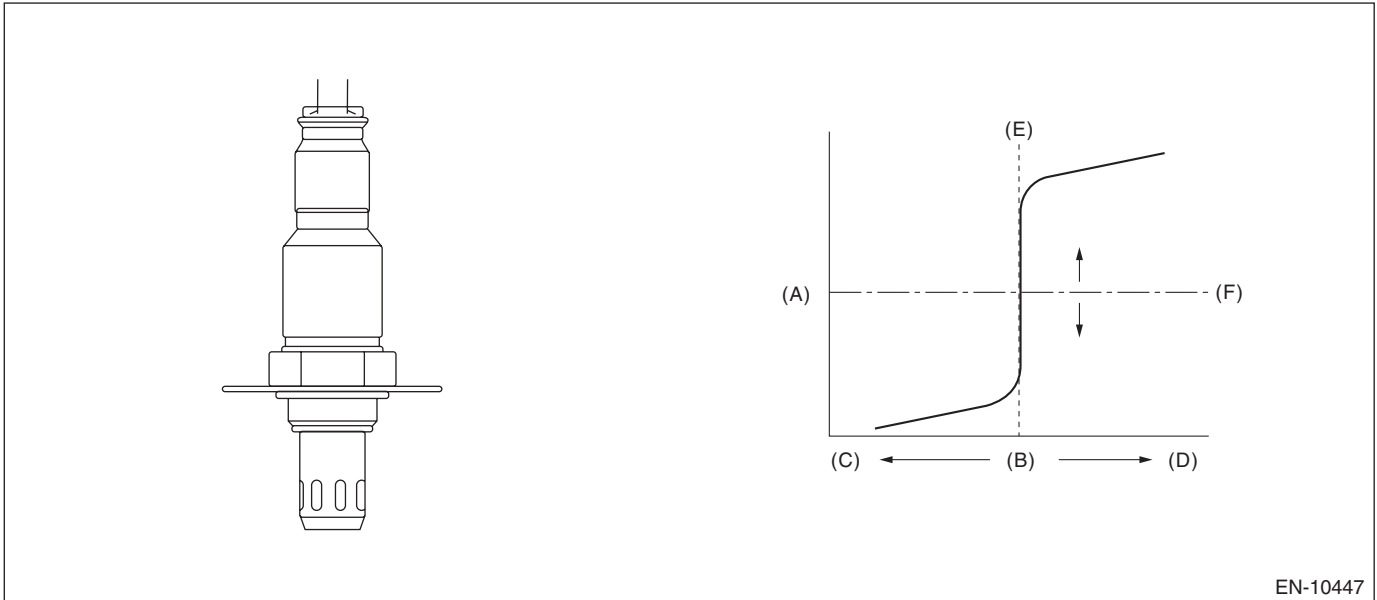

EN-10447

(A) Electromotive force

(B) Air fuel ratio

(C) Lean

(D) Rich

(E) Theoretical air fuel ratio

(F) Comparative voltage

### 3. ENABLE CONDITIONS

Secondary Parameters	Enable Conditions
Battery voltage	$\geq 10.9$ V
Sub feedback	In operation
Amount of intake air	$\geq 10$ g/s (0.35 oz/s)
Estimated temperature of the rear oxygen sensor element	$\geq 450^{\circ}\text{C}$ ( $842^{\circ}\text{F}$ )
Enable conditions at interrupt control are as follows	
Air fuel ratio reduced from target air fuel ratio	= Value of Map
Continuous time when rear oxygen sensor output voltage is less than 0.55 V	$\geq 10$ s

#### Map

Output voltage of rear oxygen sensor V	0.00	0.10	0.15	0.30	0.40	0.50	0.60
Air fuel ratio reduced from target air fuel ratio %	15	15	5	4	4	4	4

### 4. GENERAL DRIVING CYCLE

Perform the diagnosis only once after the enable conditions have been established.

## Diagnostic Trouble Code (DTC) Detecting Criteria

### GENERAL DESCRIPTION

---

#### 5. DIAGNOSTIC METHOD

If the duration of time while the following conditions are met is longer than the time indicated, judge as NG.

#### Judgment Value

Malfunction Criteria	Threshold Value
Output voltage of rear oxygen sensor	< 0.55 V

**Time Needed for Diagnosis:** 20 seconds

**Malfunction Indicator Light Illumination:** Illuminates when malfunction occurs in 2 continuous driving cycles.

# Diagnostic Trouble Code (DTC) Detecting Criteria

GENERAL DESCRIPTION

## GO:DTC P2271 O2 SENSOR SIGNAL BIASED/STUCK RICH (BANK 1 SENSOR 2)

### 1. OUTLINE OF DIAGNOSIS

Detect the stuck of rear oxygen sensor voltage in rich state.

Detect the stuck in rich state and judge as NG if rear oxygen sensor voltage remains above the threshold value for predetermined time.

### 2. COMPONENT DESCRIPTION

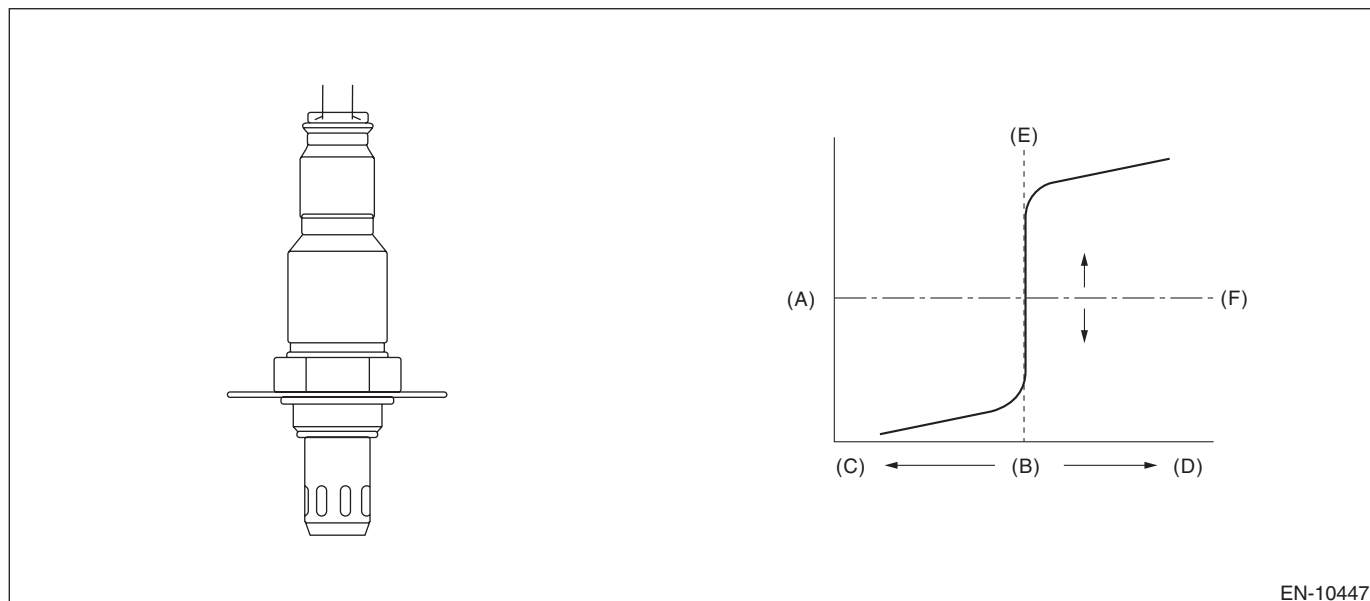

(A) Electromotive force

(B) Air fuel ratio

(C) Lean

(D) Rich

(E) Theoretical air fuel ratio

(F) Comparative voltage

### 3. ENABLE CONDITIONS

Secondary Parameters	Enable Conditions
Battery voltage	$\geq 10.9$ V
Deceleration fuel cut of 5000 ms or more	Experienced
Estimated temperature of the rear oxygen sensor element	$\geq 450^{\circ}\text{C}$ ( $842^{\circ}\text{F}$ )

### 4. GENERAL DRIVING CYCLE

Perform the diagnosis only once after the enable conditions have been established.

### 5. DIAGNOSTIC METHOD

If the duration of time while the following conditions are met is longer than the time indicated, judge as NG.

#### Judgment Value

Malfunction Criteria	Threshold Value
Output voltage of rear oxygen sensor	$> 0.15$ V

**Time Needed for Diagnosis:** 0.5 seconds

**Malfunction Indicator Light Illumination:** Illuminates when malfunction occurs in 2 continuous driving cycles.

# Diagnostic Trouble Code (DTC) Detecting Criteria

## GENERAL DESCRIPTION

### GP:DTC P2401 EVAPORATIVE EMISSION SYSTEM LEAK DETECTION PUMP CONTROL CIRCUIT LOW

#### 1. OUTLINE OF DIAGNOSIS

Detect the open or short circuit of the ELCM vacuum pump.  
Judge as NG if out of specification.

#### 2. COMPONENT DESCRIPTION

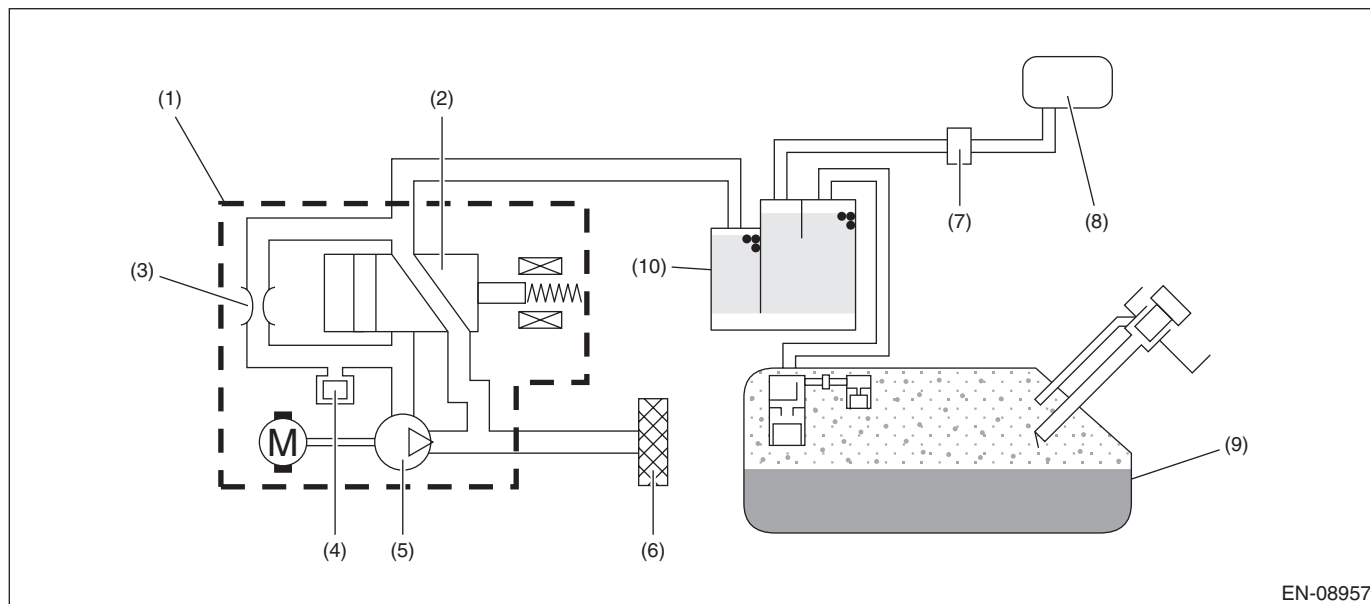

EN-08957

- |   |                                  |               |
|---|----------------------------------|---------------|
| (1) ELCM                                  | (5) Vacuum pump                  | (9) Fuel tank |
| (2) Switching valve                       | (6) Drain filter                 | (10) Canister |
| (3) Reference orifice (0.02 inch orifice) | (7) Purge control solenoid valve |               |
| (4) Pressure sensor                       | (8) Intake manifold              |               |

#### 3. ENABLE CONDITIONS

Secondary Parameters	Enable Conditions
Battery voltage	≥ 10.9
ELCM vacuum pump drive signal	OFF

#### 4. GENERAL DRIVING CYCLE

Perform the diagnosis only once after the enable conditions have been established.

#### 5. DIAGNOSTIC METHOD

If the duration of time while the following conditions are met is longer than the time indicated, judge as NG.

##### Judgment Value

Malfunction Criteria	Threshold Value
Output voltage	≤ 2.2 V

**Time Needed for Diagnosis:** 2500 ms

**Malfunction Indicator Light Illumination:** Illuminates as soon as a malfunction occurs.



# Diagnostic Trouble Code (DTC) Detecting Criteria

GENERAL DESCRIPTION

## GQ:DTC P2402 EVAPORATIVE EMISSION SYSTEM LEAK DETECTION PUMP CONTROL CIRCUIT HIGH

### 1. OUTLINE OF DIAGNOSIS

Detect the open or short circuit of the ELCM vacuum pump.

Judge as NG if out of specification.

### 2. COMPONENT DESCRIPTION

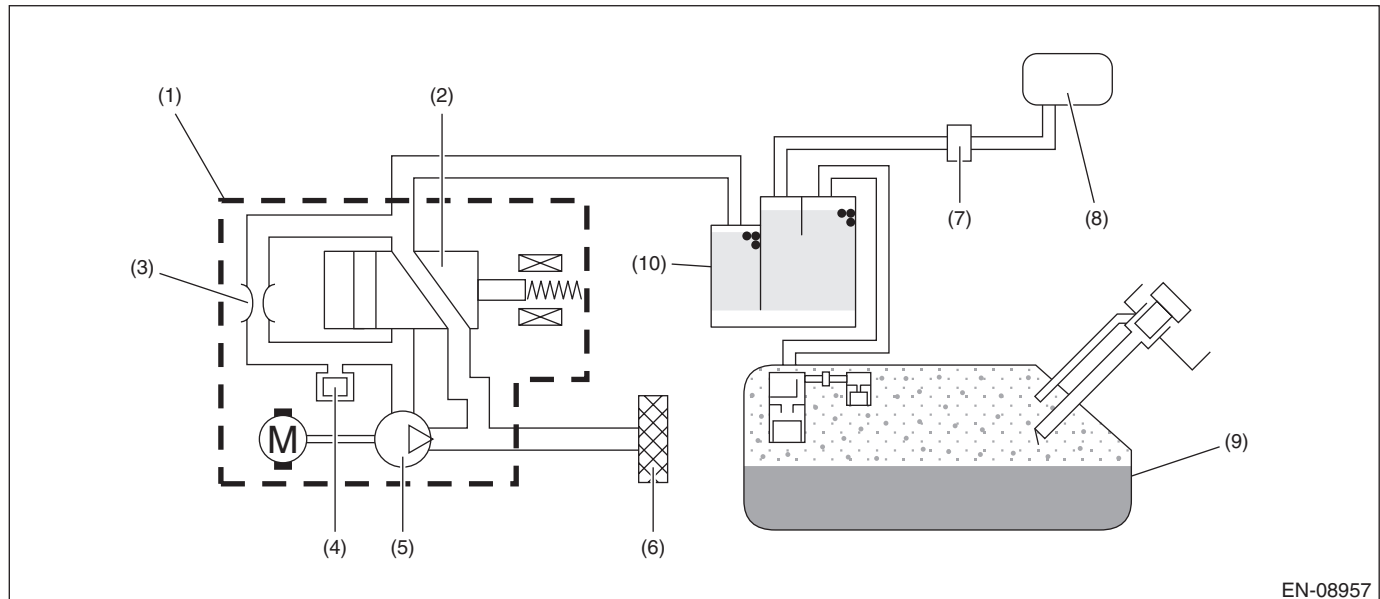

EN-08957

- |   |                                  |               |
|---|----------------------------------|---------------|
| (1) ELCM                                  | (5) Vacuum pump                  | (9) Fuel tank |
| (2) Switching valve                       | (6) Drain filter                 | (10) Canister |
| (3) Reference orifice (0.02 inch orifice) | (7) Purge control solenoid valve |               |
| (4) Pressure sensor                       | (8) Intake manifold              |               |

### 3. ENABLE CONDITIONS

Secondary Parameters	Enable Conditions
Battery voltage	≥ 10.9
ELCM vacuum pump drive signal	ON

### 4. GENERAL DRIVING CYCLE

Perform the diagnosis only once after the enable conditions have been established.

### 5. DIAGNOSTIC METHOD

If the duration of time while the following conditions are met is longer than the time indicated, judge as NG.

#### Judgment Value

Malfunction Criteria	Threshold Value
Output current	≥ 5 A

**Time Needed for Diagnosis:** 2250 ms

**Malfunction Indicator Light Illumination:** Illuminates as soon as a malfunction occurs.

## Diagnostic Trouble Code (DTC) Detecting Criteria

### GENERAL DESCRIPTION

---

## **GR:DTC P2404 EVAPORATIVE EMISSION SYSTEM LEAK DETECTION PUMP SENSE CIRCUIT RANGE/PERFORMANCE**

### **1. OUTLINE OF DIAGNOSIS**

#### NOTE:

For the detection standard, refer to DTC P0455. <Ref. to GD(w/o STI)-134, DTC P0455 EVAPORATIVE EMISSION SYSTEM LEAK DETECTED (LARGE LEAK), Diagnostic Trouble Code (DTC) Detecting Criteria.>

## GS:DTC P2419 EVAPORATIVE EMISSION SYSTEM SWITCHING VALVE CONTROL CIRCUIT LOW

### 1. OUTLINE OF DIAGNOSIS

Detect the open or short circuit of the ELCM switching valve.  
Judge as NG if out of specification.

### 2. COMPONENT DESCRIPTION

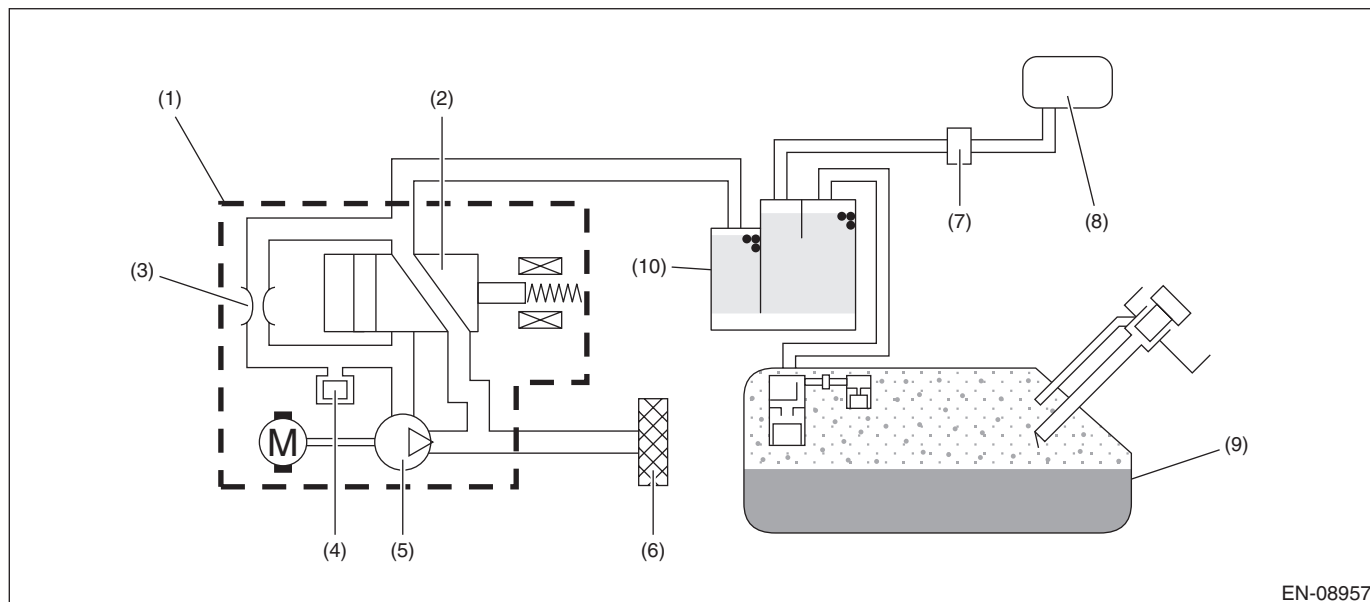

EN-08957

- |   |                                  |               |
|---|----------------------------------|---------------|
| (1) ELCM                                  | (5) Vacuum pump                  | (9) Fuel tank |
| (2) Switching valve                       | (6) Drain filter                 | (10) Canister |
| (3) Reference orifice (0.02 inch orifice) | (7) Purge control solenoid valve |               |
| (4) Pressure sensor                       | (8) Intake manifold              |               |

### 3. ENABLE CONDITIONS

Secondary Parameters	Enable Conditions
Battery voltage	≥ 10.9
ELCM switching valve drive signal	OFF

### 4. GENERAL DRIVING CYCLE

Perform the diagnosis continuously after the enable conditions have been established.

### 5. DIAGNOSTIC METHOD

If the duration of time while the following conditions are met is longer than the time indicated, judge as NG.

#### Judgment Value

Malfunction Criteria	Threshold Value
Output voltage	≤ 2.2 V

**Time Needed for Diagnosis:** 2500 ms

**Malfunction Indicator Light Illumination:** Illuminates as soon as a malfunction occurs.

# Diagnostic Trouble Code (DTC) Detecting Criteria

## GENERAL DESCRIPTION

### GT:DTC P2420 EVAPORATIVE EMISSION SYSTEM SWITCHING VALVE CONTROL CIRCUIT HIGH

#### 1. OUTLINE OF DIAGNOSIS

Detect the open or short circuit of the ELCM switching valve.

Judge as NG if out of specification.

#### 2. COMPONENT DESCRIPTION

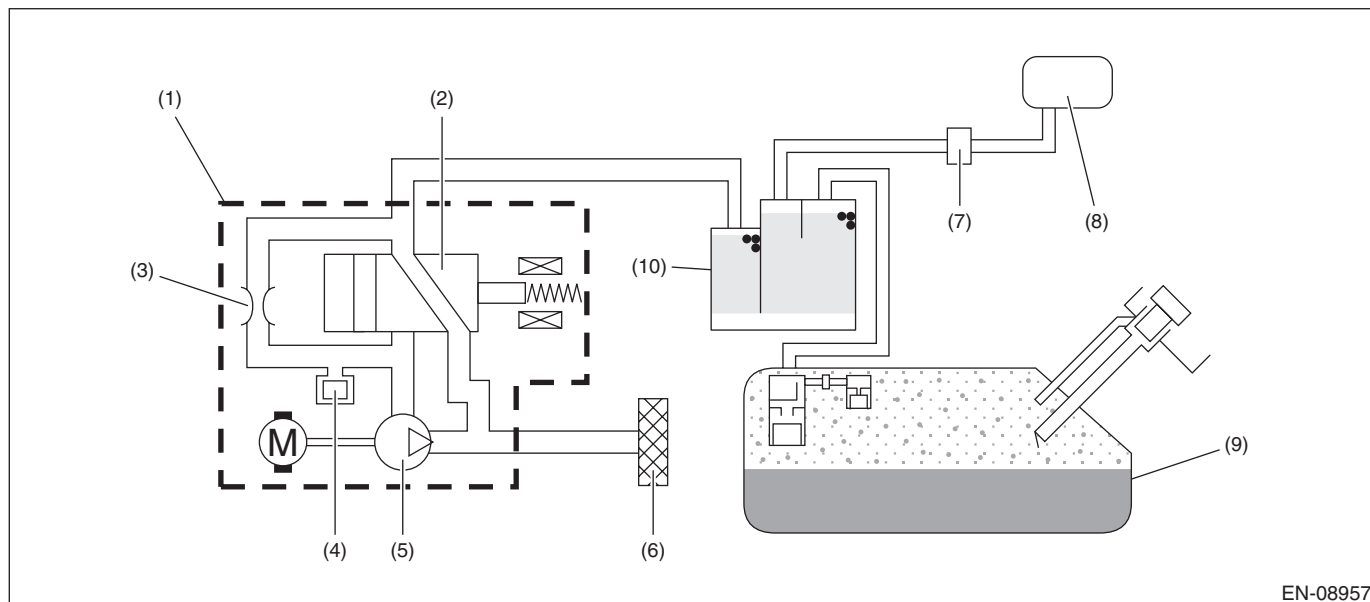

EN-08957

- |   |                                  |               |
|---|----------------------------------|---------------|
| (1) ELCM                                  | (5) Vacuum pump                  | (9) Fuel tank |
| (2) Switching valve                       | (6) Drain filter                 | (10) Canister |
| (3) Reference orifice (0.02 inch orifice) | (7) Purge control solenoid valve |               |
| (4) Pressure sensor                       | (8) Intake manifold              |               |

#### 3. ENABLE CONDITIONS

Secondary Parameters	Enable Conditions
Battery voltage	$\geq 10.9$
ELCM switching valve drive signal	ON

#### 4. GENERAL DRIVING CYCLE

Perform the diagnosis continuously after the enable conditions have been established.

#### 5. DIAGNOSTIC METHOD

If the duration of time while the following conditions are met is longer than the time indicated, judge as NG.

##### Judgment Value

Malfunction Criteria	Threshold Value
Output current	$\geq 5$ A

**Time Needed for Diagnosis:** 2250 ms

**Malfunction Indicator Light Illumination:** Illuminates as soon as a malfunction occurs.

# Diagnostic Trouble Code (DTC) Detecting Criteria

GENERAL DESCRIPTION

## GU:DTC P2530 IGNITION SWITCH RUN POSITION CIRCUIT

### 1. OUTLINE OF DIAGNOSIS

Detect instantaneous open in ignition switch input circuit to ECM.  
Judge as NG if out of specification.

### 2. COMPONENT DESCRIPTION

ECM monitors the voltage of the ignition switch input circuit. Judge as ignition switch ON when the voltage is the specified value or more.

### 3. ENABLE CONDITIONS

Secondary Parameters	Enable Conditions
Battery voltage	$\geq 10.9$ V
Engine speed	$\geq 475$ rpm

### 4. GENERAL DRIVING CYCLE

Always perform the diagnosis continuously after the enable conditions have been established.

### 5. DIAGNOSTIC METHOD

Judge as NG when the following conditions are established within the predetermined time.

#### Judgment Value

Malfunction Criteria	Threshold Value
Number of instantaneous opens in ignition switch input circuit	$\geq 5$ times

**Time Needed for Diagnosis:** 5 seconds

**Malfunction Indicator Light Illumination:** Illuminates as soon as a malfunction occurs.

# Diagnostic Trouble Code (DTC) Detecting Criteria

## GENERAL DESCRIPTION

---

### GV:DTC P2610 ECM/PCM INTERNAL ENGINE OFF TIMER PERFORMANCE

#### 1. OUTLINE OF DIAGNOSIS

Confirm the engine off timer accuracy by comparing engine off timer and power supply IC timer after ignition switch is turned to OFF.

This diagnosis consists of the following six cases. Judge as NG when in any one of the following cases, abnormality is detected.

Case number	Diagnosis function	Time Needed for Diagnosis:
Case #1	Diagnose the difference between wake-up request time and power supply IC timer.	Less than 1 second
Case #2	Diagnose the time in power supply IC timer before wake up.	Less than 1 second
Case #3	Diagnose the communication error between main CPU and sub CPU.	2 s
Case #4	Diagnose the communication error between main CPU and power supply IC.	2 s
Case #5	Diagnose the operation status abnormality in main CPU and sub CPU.	2 s
Case #6	Diagnose the ignition switch status abnormality in main CPU and sub CPU.	2 s

# Diagnostic Trouble Code (DTC) Detecting Criteria

GENERAL DESCRIPTION

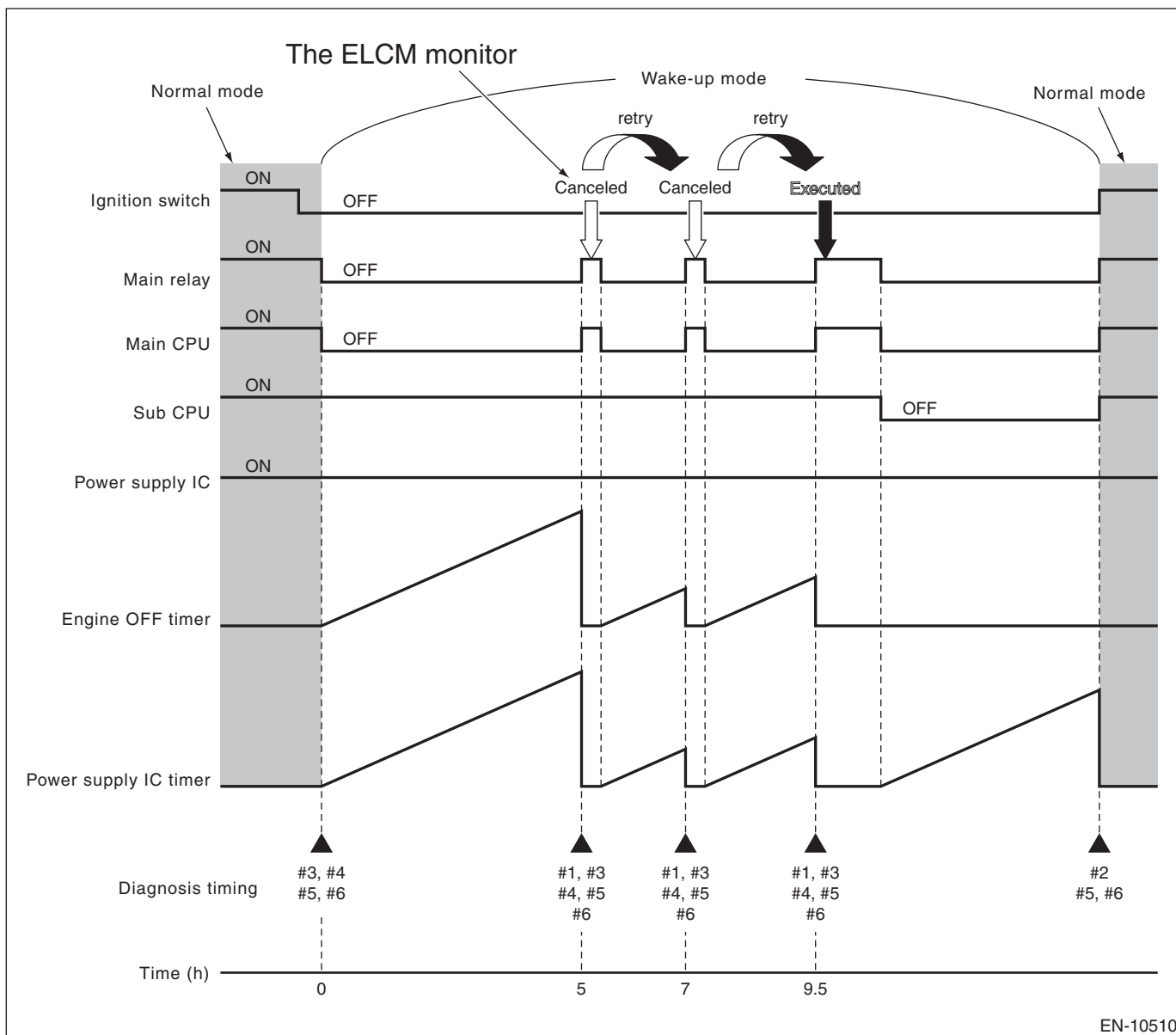

**NOTE:**

- Normal mode: main relay and ignition switch is ON.
- Wake-up mode: In soaking

**2. COMPONENT DESCRIPTION**

The engine off timer is built into the ECM.

**3. ENABLE CONDITIONS**

Secondary Parameters	Enable Conditions
<Case #1>	
Battery voltage	≥ 10.9 V
Main CPU	Wake-up mode
<Case #2>	
Battery voltage	≥ 10.9 V
Main CPU	Normal mode
Wake-up experience flag	OFF
<Case #3, #4, #5 and #6>	
Battery voltage	≥ 10.9 V

# Diagnostic Trouble Code (DTC) Detecting Criteria

## GENERAL DESCRIPTION

### 4. GENERAL DRIVING CYCLE

- **Case #1:** Perform the diagnosis only once when wake-up operates after the ignition switch is OFF.
- **Case #2:** Perform the diagnosis only once when the following driving cycle starts after the ignition switch is OFF.
- **Case #3:** Perform the diagnosis only once after the enable conditions have been established.
- **Case #4:** Perform the diagnosis only once after the enable conditions have been established.
- **Case #5:** Perform the diagnosis only once after the enable conditions have been established.
- **Case #6:** Perform the diagnosis only once after the enable conditions have been established.

### 5. DIAGNOSTIC METHOD

#### <Case #1>

Judge as abnormal in engine off timer or power supply IC timer when the difference between wake-up request time and power supply IC timer exceeds the threshold value.

When the sub CPU is faulty, wake-up timing is either advancing or retarding compared with normal timing.

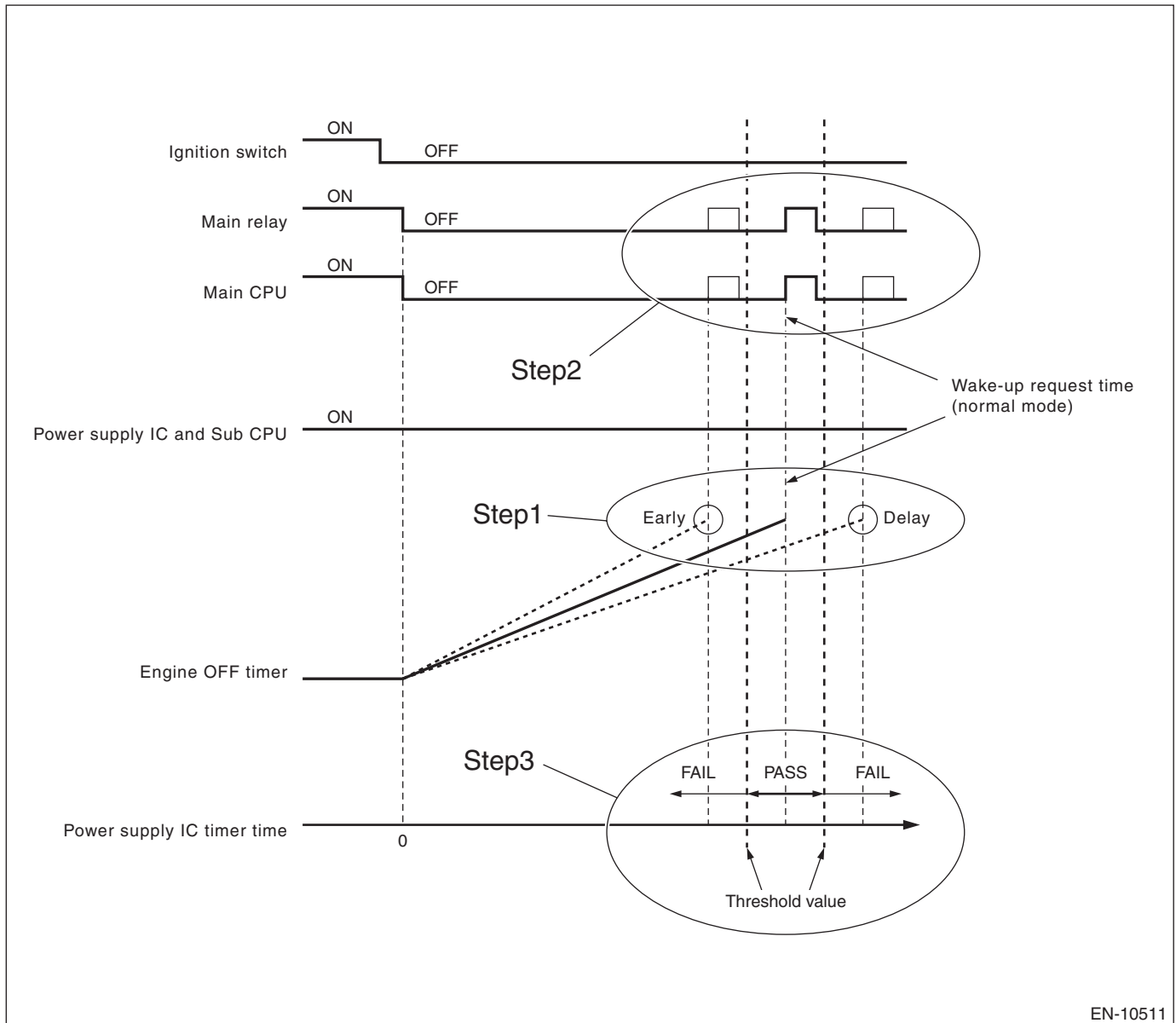

EN-10511

Processed in order Step 1 through Step 3.



# Diagnostic Trouble Code (DTC) Detecting Criteria

GENERAL DESCRIPTION

Judge as NG when the following conditions are established.

## Judgment Value

Malfunction Criteria	Threshold Value
$ (Power\ supply\ IC\ timer) - (Wake\text{-}up\ request\ time)  / Wake\text{-}up\ request\ time$	> 0.24

**Time Needed for Diagnosis:** Less than 1 second

**Malfunction Indicator Light Illumination:** Illuminates when malfunction occurs in 2 continuous driving cycles.

### <Case #2>

Judge as abnormal in engine off timer when the power supply IC timer exceeds the wake-up request time before wake up.

When case #1 is not performed, perform case #2.

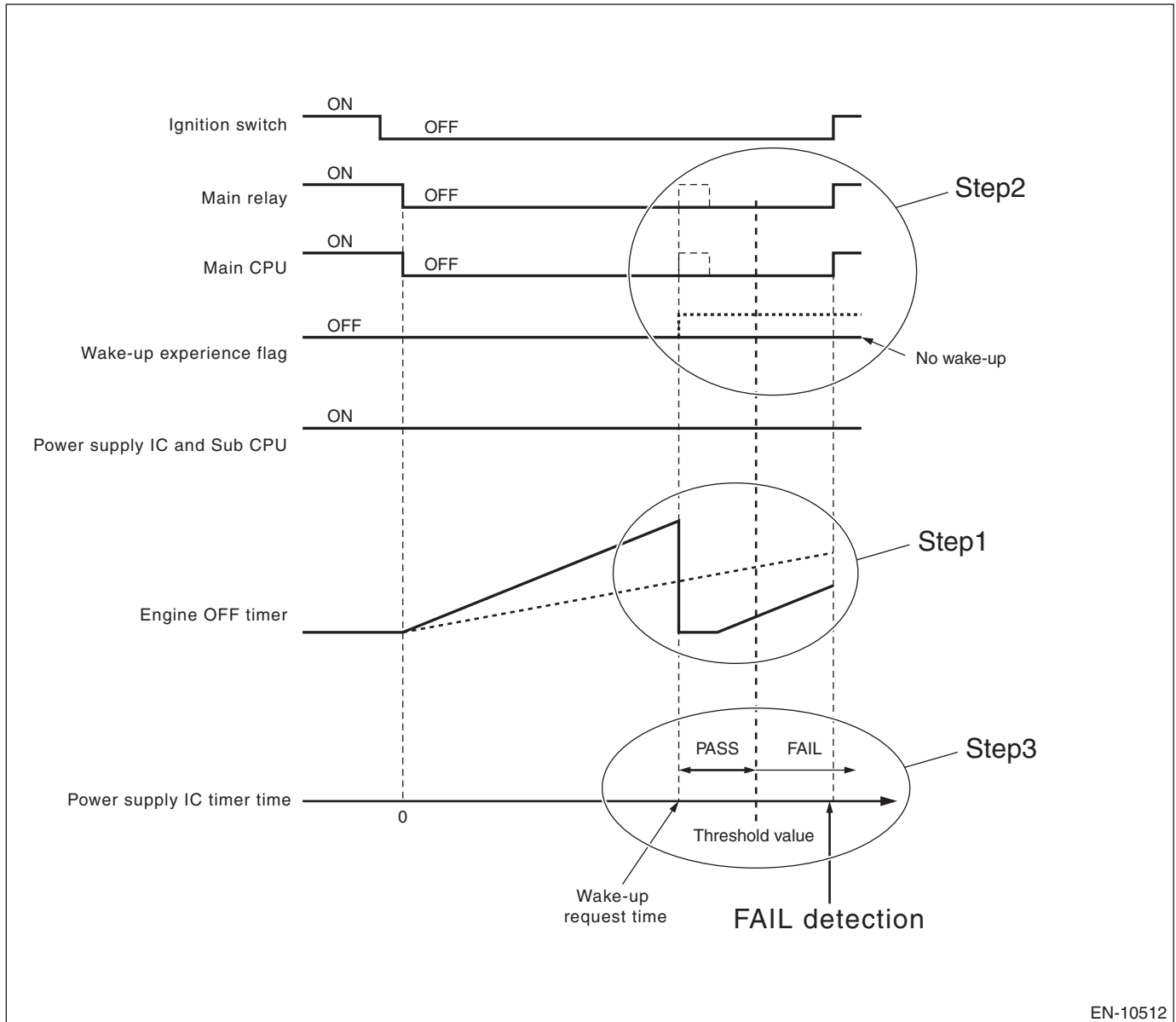

Processed in order Step 1 through Step 3.

## Diagnostic Trouble Code (DTC) Detecting Criteria

### GENERAL DESCRIPTION

Judge as NG when the following conditions are established.

#### Judgment Value

Malfunction Criteria	Threshold Value
$\{(Power\ supply\ IC\ timer) - (Wake\text{-}up\ request\ time)\} / Wake\text{-}up\ request\ time$	> 0.24

**Time Needed for Diagnosis:** Less than 1 second

**Malfunction Indicator Light Illumination:** Illuminates when malfunction occurs in 2 continuous driving cycles.

#### <Case #3>

Diagnose the communication error between main CPU and sub CPU.

Judge as NG when the wake-up time required from main CPU and the wake-up time received from sub CPU are different.

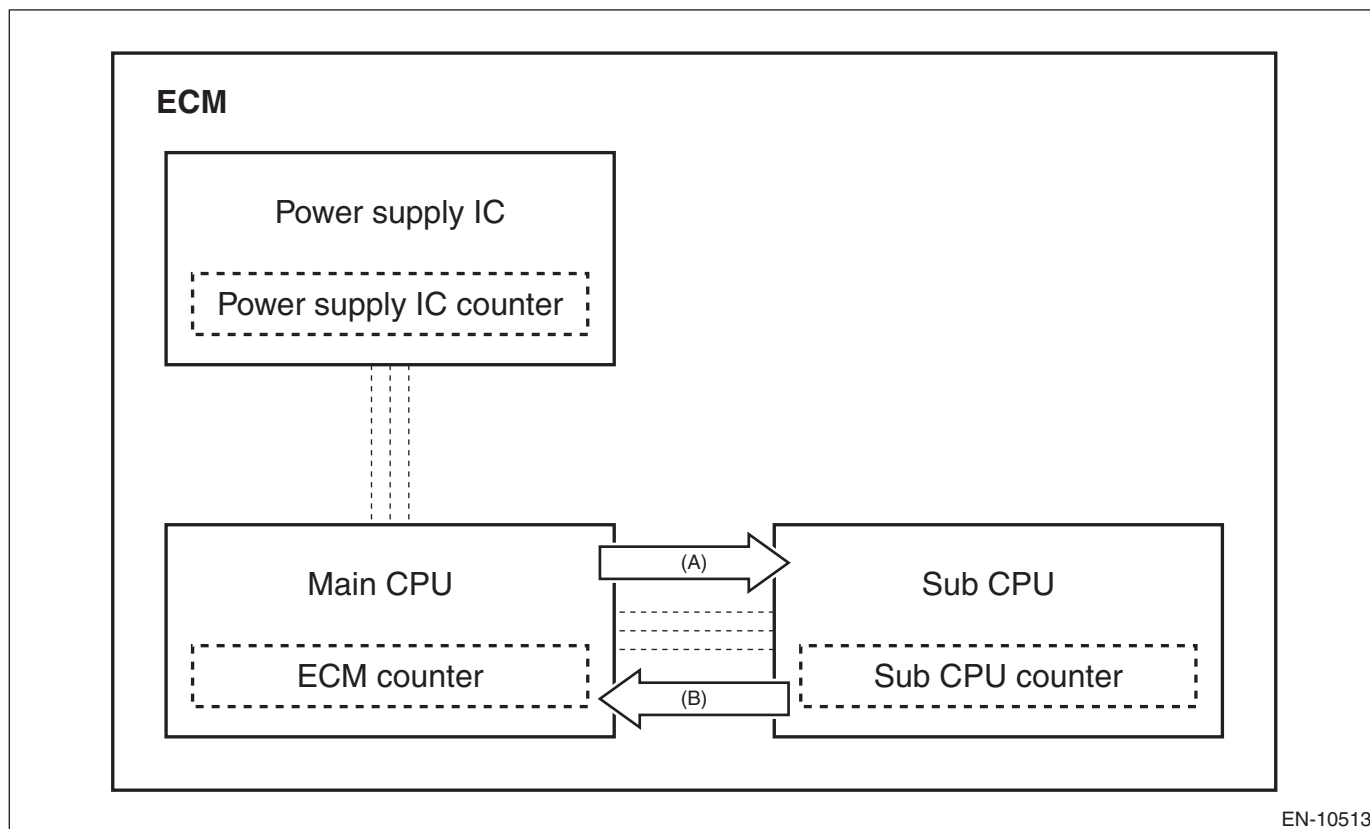

(A) Main CPU demands wake-up time to sub CPU.

(B) Sub CPU sends back wake-up time required by main CPU.

Judge as NG when the following conditions are established.

#### Judgment Value

Malfunction Criteria	Threshold Value
Wake-up time required by main CPU	$\neq$ Wake-up time sent back by sub CPU

**Time Needed for Diagnosis:** 2 seconds

**Malfunction Indicator Light Illumination:** Illuminates when malfunction occurs in 2 continuous driving cycles.

# Diagnostic Trouble Code (DTC) Detecting Criteria

GENERAL DESCRIPTION

## <Case #4>

Diagnose the communication error between main CPU and power supply IC.

Judge as NG when the signal required by main CPU and the signal received from power supply IC are different.

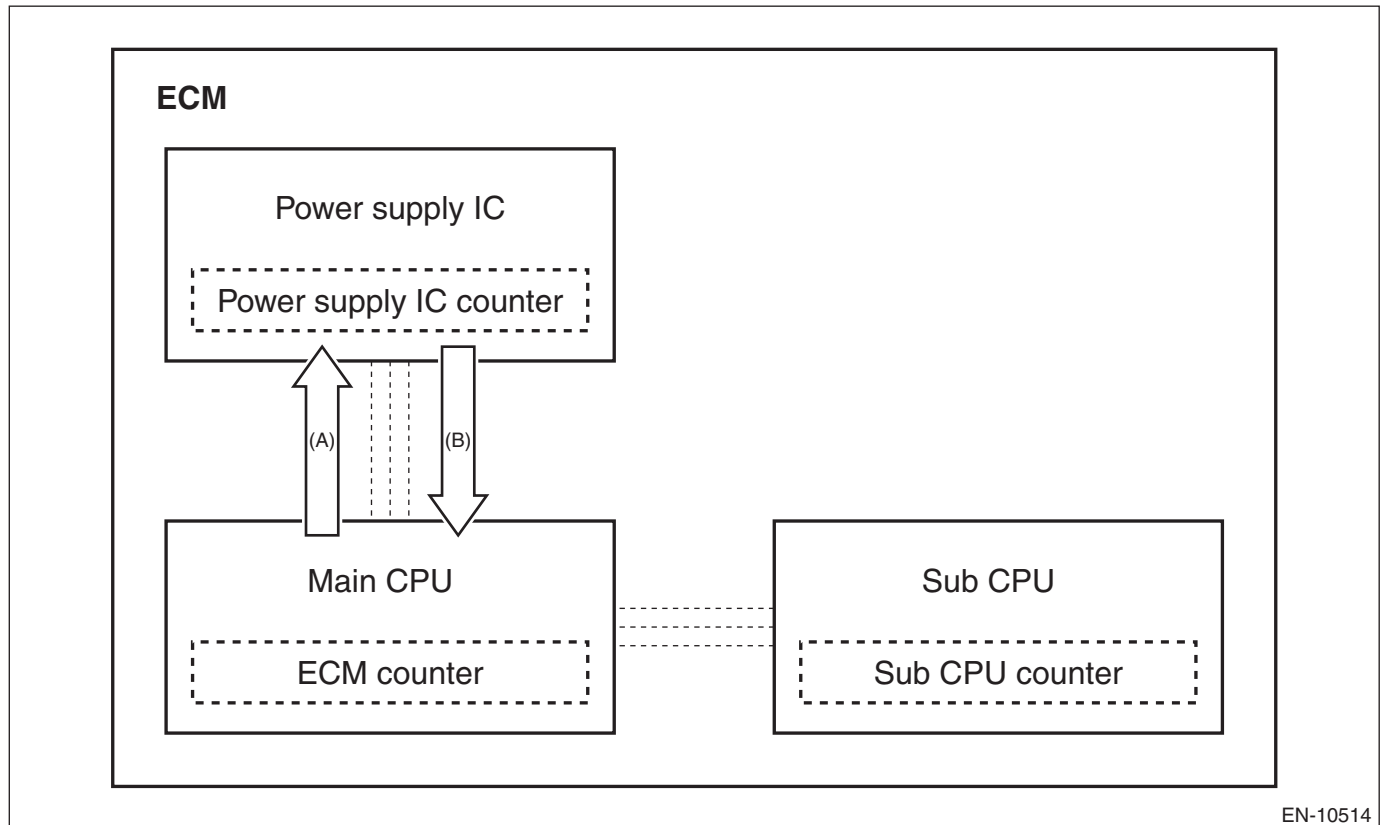

EN-10514

(A) Main CPU demands signals for measuring the wake-up time to power supply IC.

(B) Main CPU receives signals for measuring the wake-up time from power supply IC.

Judge as NG when the following conditions are established.

### Judgment Value

Malfunction Criteria	Threshold Value
Signal required by main CPU	≠ Signal received from power supply IC

**Time Needed for Diagnosis:** 2 seconds

**Malfunction Indicator Light Illumination:** Illuminates when malfunction occurs in 2 continuous driving cycles.

# Diagnostic Trouble Code (DTC) Detecting Criteria

## GENERAL DESCRIPTION

### <Case #5>

On main CPU and sub CPU, there are two operation status: “normal mode” and “wake-up mode”.  
 Perform diagnosis for CPU operation status abnormality by detecting the difference in operating status of main CPU and sub CPU.  
 Judge as NG when main CPU and sub CPU is different in operating status.

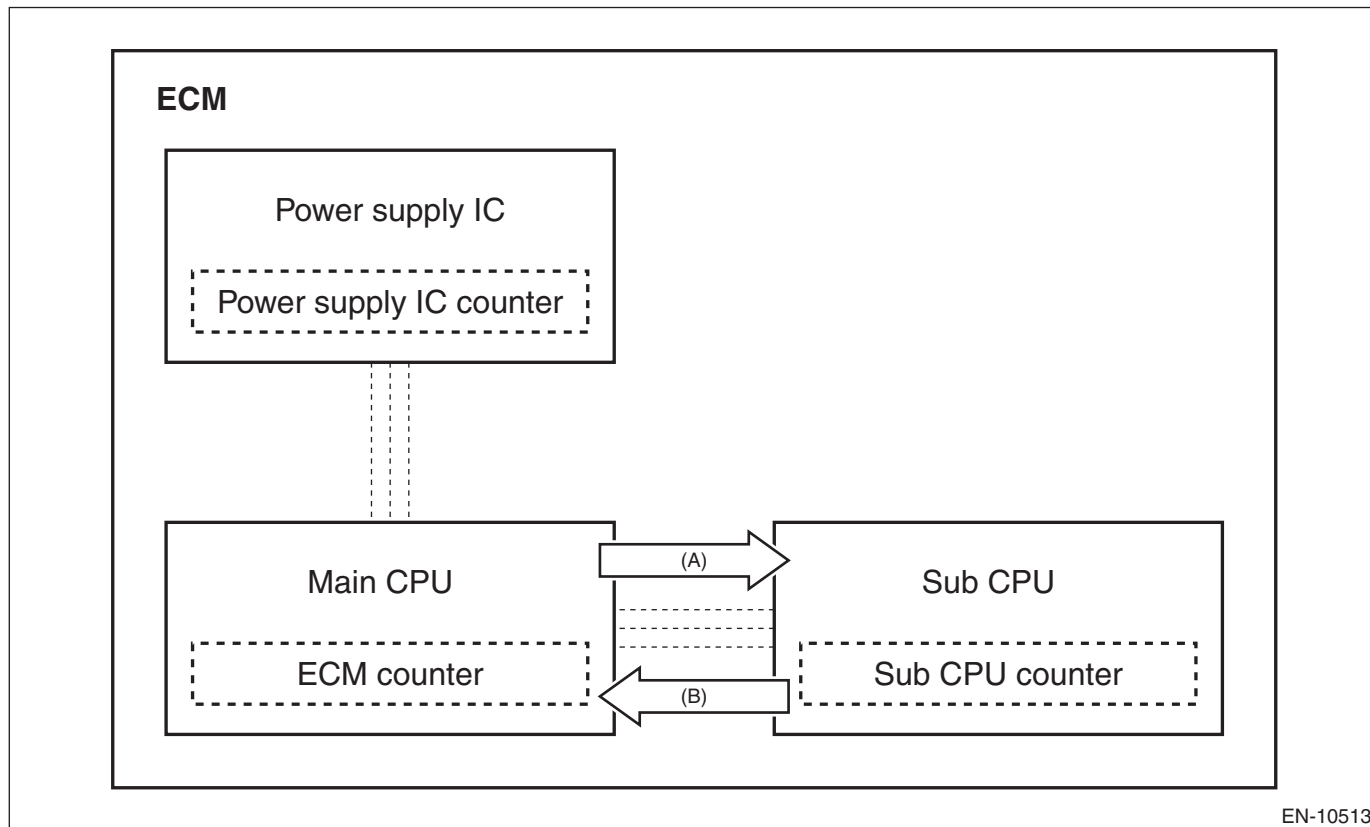

EN-10513

- (A) Main CPU demands diagnosis for operating status to sub CPU.
- (B) Sub CPU sends back the operating status to main CPU.

Judge as NG when the following conditions are established.

### Judgment Value

Malfunction Criteria	Threshold Value
Operating status of main CPU	≠ Operating status of sub CPU

**Time Needed for Diagnosis:** 2 seconds

**Malfunction Indicator Light Illumination:** Illuminates when malfunction occurs in 2 continuous driving cycles.

### <Case #6>

Perform diagnosis for ignition switch status abnormality by detecting the difference in ignition switch status (ON or OFF) of main CPU and sub CPU.

# Diagnostic Trouble Code (DTC) Detecting Criteria

GENERAL DESCRIPTION

Judge as NG when main CPU and sub CPU are different in ignition switch status.

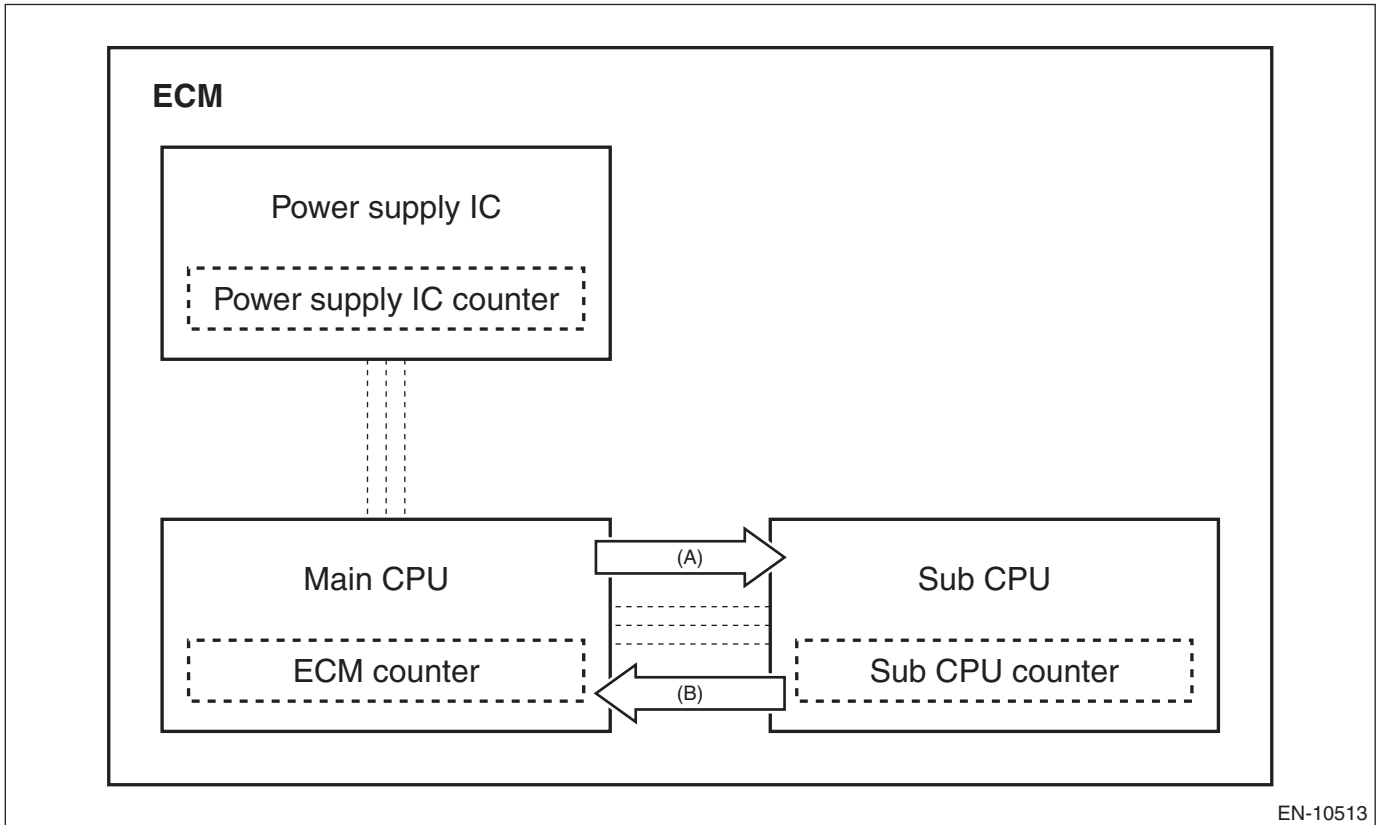

- (A) Main CPU demands ignition switch status to sub CPU.
- (B) Sub CPU sends back ignition switch status to main CPU.

Judge as NG when the following conditions are established.

### Judgment Value

Malfunction Criteria	Threshold Value
Ignition switch status of main CPU	≠ Ignition switch status of sub CPU

**Time Needed for Diagnosis:** 2 seconds

**Malfunction Indicator Light Illumination:** Illuminates when malfunction occurs in 2 continuous driving cycles.

# Diagnostic Trouble Code (DTC) Detecting Criteria

## GENERAL DESCRIPTION

---

### **GW:DTC U0073 CONTROL MODULE COMMUNICATION BUS OFF**

#### **1. OUTLINE OF DIAGNOSIS**

Detect malfunction of CAN communication.

Judge as NG when CAN communication failure has occurred.

#### **2. COMPONENT DESCRIPTION**

*(Common Specifications)*

*CAN Protocol 2.0 B (Active)*

*Frame Format: 11 Bit ID Frame (Standard Frame)*

*Conforms to ISO11898*

*Communication Speed: 500 kbps*

#### **3. ENABLE CONDITIONS**

Secondary Parameters	Enable Conditions
Battery voltage	$\geq 10.9$ V

#### **4. GENERAL DRIVING CYCLE**

Always perform the diagnosis continuously.

#### **5. DIAGNOSTIC METHOD**

Judge as NG when the following conditions are established.

##### **Judgment Value**

Malfunction Criteria	Threshold Value
CAN bus condition	Bus off

**Time Needed for Diagnosis:** 436 ms

**Malfunction Indicator Light Illumination:** Illuminates as soon as a malfunction occurs.

# Diagnostic Trouble Code (DTC) Detecting Criteria

GENERAL DESCRIPTION

## GX:DTC U0077 LIN COMMUNICATION BUS "ECM/PCM" OFF

### 1. OUTLINE OF DIAGNOSIS

Detect malfunction of LIN communication.

Judge as NG when the data sent/received via LIN communication is abnormal.

### 2. COMPONENT DESCRIPTION

LIN communication is used to send/receive data between ECM and battery sensor.

### 3. ENABLE CONDITIONS

Secondary Parameters	Enable Conditions
Battery voltage	$\geq 10.9$ V

### 4. GENERAL DRIVING CYCLE

Always perform the diagnosis continuously after the enable conditions have been established.

### 5. DIAGNOSTIC METHOD

If the duration of time while the following conditions are met is longer than the time indicated, judge as NG.

#### Judgment Value

Malfunction Criteria	Threshold Value
Data sent/received with control modules connected to LIN	Does not change or Checksum error

**Time Needed for Diagnosis:** 1.5 seconds

**Malfunction Indicator Light Illumination:** Does not illuminate.

# Diagnostic Trouble Code (DTC) Detecting Criteria

## GENERAL DESCRIPTION

### **GY:DTC U0101 LOST COMMUNICATION WITH TCM**

#### **1. OUTLINE OF DIAGNOSIS**

Detect malfunction of CAN communication.

Judge as NG when CAN communication failure between TCM, VDC CM and combination meter has occurred.

#### **2. COMPONENT DESCRIPTION**

*(Common Specifications)*

*CAN Protocol 2.0 B (Active)*

*Frame Format: 11 Bit ID Frame (Standard Frame)*

*Conforms to ISO11898*

*Communication Speed: 500 kbps*

#### **3. ENABLE CONDITIONS**

Secondary Parameters	Enable Conditions
Battery voltage	$\geq 10.9$ V

#### **4. GENERAL DRIVING CYCLE**

Always perform the diagnosis continuously.

#### **5. DIAGNOSTIC METHOD**

Judge as NG when the following conditions are established.

##### **Judgment Value**

Malfunction Criteria	Threshold Value
ID received from control module connected to CAN	None

**Time Needed for Diagnosis:** 500 ms

**Malfunction Indicator Light Illumination:** Illuminates as soon as a malfunction occurs.

### **GZ:DTC U0122 LOST COMMUNICATION WITH VEHICLE DYNAMICS CONTROL MODULE**

#### **1. OUTLINE OF DIAGNOSIS**

NOTE:

For the detection standard, refer to DTC U0101. <Ref. to GD(w/o STI)-242, DTC U0101 LOST COMMUNICATION WITH TCM, Diagnostic Trouble Code (DTC) Detecting Criteria.>

### **HA:DTC U0155 LOST COMMUNICATION WITH INSTRUMENT PANEL CLUSTER (IPC) CONTROL MODULE**

#### **1. OUTLINE OF DIAGNOSIS**

NOTE:

For the detection standard, refer to DTC U0101. <Ref. to GD(w/o STI)-242, DTC U0101 LOST COMMUNICATION WITH TCM, Diagnostic Trouble Code (DTC) Detecting Criteria.>



# Diagnostic Trouble Code (DTC) Detecting Criteria

GENERAL DESCRIPTION

## HB:DTC U0402 INVALID DATA RECEIVED FROM TCM

### 1. OUTLINE OF DIAGNOSIS

Detect malfunction of CAN communication.

Judge as NG when data received from TCM, VDC CM and combination meter is not normal.

### 2. COMPONENT DESCRIPTION

*(Common Specifications)*

*CAN Protocol 2.0 B (Active)*

*Frame Format: 11 Bit ID Frame (Standard Frame)*

*Conforms to ISO11898*

*Communication Speed: 500 kbps*

### 3. ENABLE CONDITIONS

Secondary Parameters	Enable Conditions
Battery voltage	$\geq 10.9$ V

### 4. GENERAL DRIVING CYCLE

Always perform the diagnosis continuously.

### 5. DIAGNOSTIC METHOD

Judge as NG when the following conditions are established.

#### Judgment Value

Malfunction Criteria	Threshold Value
Data updated from control module connected to CAN	None

**Time Needed for Diagnosis:** 2 seconds

**Malfunction Indicator Light Illumination:** Illuminates as soon as a malfunction occurs.

## HC:DTC U0416 INVALID DATA RECEIVED FROM VEHICLE DYNAMICS CONTROL MODULE

### 1. OUTLINE OF DIAGNOSIS

NOTE:

For the detection standard, refer to DTC U0402. <Ref. to GD(w/o STI)-243, DTC U0402 INVALID DATA RECEIVED FROM TCM, Diagnostic Trouble Code (DTC) Detecting Criteria.>

## HD:DTC U0423 INVALID DATA RECEIVED FROM INSTRUMENT PANEL CLUSTER CONTROL MODULE

### 1. OUTLINE OF DIAGNOSIS

NOTE:

For the detection standard, refer to DTC U0402. <Ref. to GD(w/o STI)-243, DTC U0402 INVALID DATA RECEIVED FROM TCM, Diagnostic Trouble Code (DTC) Detecting Criteria.>

# Diagnostic Trouble Code (DTC) Detecting Criteria

## GENERAL DESCRIPTION

---

### HE:DTC U1712 LOST LIN COMMUNICATION WITH BATTERY "1" MONITOR MODULE

#### 1. OUTLINE OF DIAGNOSIS

Detect malfunction of LIN communication.

Judge as NG when LIN communication failure has occurred with the battery sensor.

#### 2. COMPONENT DESCRIPTION

The battery sensor monitors the data of battery voltage, current, temperature, etc. ECM receives these data via LIN communication with the battery sensor.

#### 3. ENABLE CONDITIONS

Secondary Parameters	Enable Conditions
Battery voltage	$\geq 10.9$ V

#### 4. GENERAL DRIVING CYCLE

Always perform the diagnosis continuously after the enable conditions have been established.

#### 5. DIAGNOSTIC METHOD

If the duration of time while the following conditions are met is longer than the time indicated, judge as NG.

##### Judgment Value

Malfunction Criteria	Threshold Value
Data received from control modules connected to LIN	Does not change or Checksum error

**Time Needed for Diagnosis:** 2 seconds

**Malfunction Indicator Light Illumination:** Does not illuminate.

## TRANSMISSION SECTION

This service manual has been prepared to provide SUBARU service personnel with the necessary information and data for the correct maintenance and repair of SUBARU vehicles.

This manual includes the procedures for maintenance, disassembling, reassembling, inspection and adjustment of components and diagnostics for guidance of experienced mechanics.

Please peruse and utilize this manual fully to ensure complete repair work for satisfying our customers by keeping their vehicle in optimum condition. When replacement of parts during repair work is needed, be sure to use SUBARU genuine parts.

All information, illustration and specifications contained in this manual are based on the latest product information available at the time of publication approval.

CONTROL SYSTEMS

CS

CONTINUOUSLY VARIABLE  
TRANSMISSION

CVT(TR690)

CONTINUOUSLY VARIABLE  
TRANSMISSION (DIAGNOSTICS)

CVT(diag)

GENERAL DESCRIPTION (CVT)

GD(CVT)

MANUAL TRANSMISSION AND  
DIFFERENTIAL

6MT(TY75)

MANUAL TRANSMISSION AND  
DIFFERENTIAL

6MT(TY85)

MANUAL TRANSMISSION AND  
DIFFERENTIAL (DIAGNOSTICS)

6MT(diag)

CLUTCH SYSTEM

CL



# CONTROL SYSTEMS

# CS

---

	<b>Page</b>
1. General Description .....	2
2. AT Shift Lock Control System .....	7
3. Select Lever .....	24
4. Select Cable .....	42
5. AT Shift Lock Solenoid and "P" Range Switch .....	50
6. Body Integrated Unit .....	53
7. MT Gear Shift Lever .....	54
8. MT Gear Shift Cable .....	85
9. MT Gear Select Cable .....	94
10. Reverse Check Cable .....	110
11. General Diagnostic Table .....	127